

Received 2 September 2023, accepted 7 September 2023, date of publication 11 September 2023, date of current version 20 September 2023.

Digital Object Identifier 10.1109/ACCESS.2023.3313979

RESEARCH ARTICLE

Reserve Provision in the Optimal Planning of Off-Grid Power Systems: Impact of Storage and Renewable Energy

ENRICO GIGLIO^{1,2,3}, RICCARDO NOVO^{1,2,3}, GIULIANA MATTIAZZO^{1,2}, AND DAVIDE FIORITI⁴, (Member, IEEE)

¹Dipartimento di Ingegneria Meccanica e Aerospaziale, Politecnico di Torino, 10129 Turin, Italy

²Marine Offshore Renewable Energy Laboratory, Politecnico di Torino, 10129 Turin, Italy

³Energy Center Lab, Politecnico di Torino, 10129 Turin, Italy

⁴Dipartimento di Ingegneria dell'Energia, dei Sistemi, del Territorio e delle Costruzioni, Università di Pisa, 56122 Pisa, Italy

Corresponding author: Enrico Giglio (enrico.giglio@polito.it)

This work was supported by the Politecnico di Torino through the CRUI CARE Agreement.

ABSTRACT The increasing penetration of variable renewable energy sources is progressively eroding the ability of conventional power plants to ensure grid stability. Alternative assets, including storage and control systems, are required to fill the gap and maintain the system stable, but all contributions should be previously analysed and studied by means of energy models. However, the modelling of operational constraints such as reserve requirements leads to increased computational burden, especially when employing long-term planning methods with unit-commitment needs. Therefore, planning tools often approximate or neglect reserve needs, leading to major sizing errors. This paper presents a novel model and policy recommendations for integrating short-term aspects and power reserve requirements in the planning of off-grid microgrids. The developed framework includes the formulation of an accurate cost and unit commitment model for fuel-fired generators, the formalisation of power reserve requirements and the representation of the contribution of storage and non-dispatchable technologies to power reserve. The mathematical formulation of the different assets is explored, also investigating the mutual influence of the modeled phenomena. The approach is implemented on a Mediterranean non-interconnected island. The results show acceptable trade-off between computation time and accuracy in one-year hourly simulations. Evidence demonstrates that ignoring the reserve requirements may lead to a 30% misjudgment of costs and an underestimation of the necessary reserve requirements. Enabling storage to provide reserve significantly reduces overall system costs (up to -20%), decreases fuel consumption (-35%), and improves resilience, hence suggesting the pivotal role of storage in providing reserve.

INDEX TERMS Renewable energy sources, power system stability, hybrid power systems, microgrids, islanding.

NOMENCLATURE

A. Indices and Sets

| | |
|-----|---|
| g | Indices of Fuel-fired generator (FFG) unit. |
| r | Indices of vRES generation unit |
| s | Indices of storage units. |

| | |
|------------|--|
| t | Indices of operating snapshots $t = 1, \dots, t_{end}$. |
| Ω_G | Set of FFGs. |
| Ω_R | Set of vRES generation techs. |
| Ω_S | Set of storages. |

B. Parameters

| | |
|----------|---|
| | Fuel-fired generators. |
| $d_g(t)$ | Dispatch of g -th FFG unit at t -th timestep. |

The associate editor coordinating the review of this manuscript and approving it for publication was Yonghao Gui¹.

| | |
|--------------------|--|
| $P_{nom,g}$ | Nominal power of g-th FFG. |
| $s_g(t)$ | Status of g-th FFG at t-th timestep. |
| | Objective functions. |
| cc_g | Capital cost of g-th FFG unit. |
| cc_r | Capital cost of v-th vRES unit. |
| cc_s | Capital cost of s-th storage unit. |
| $cc_{s,link}$ | Capital cost of the s-th converter. |
| CC_{tot} | Total Capital Cost (CC). |
| f_{obj}^{base} | Economic base objective function. |
| f_{obj} | Economic objective function. |
| $f_{e,g}$ | Extra objective term due to g-th FFGs. |
| ic | Normalized idling cost. |
| IC_g | Idling cost of g-th FFGs. |
| oc_g | Operational cost of g-th FFG unit. |
| OC_{tot} | Total Operational Cost (OC). |
| | Power demand. |
| $EL(t)$ | Total power demand at t-th timestep. |
| | Power reserve analysis. |
| fix | Fixed term of power reserve request. |
| $r_g(t)$ | Reserve by g-th FFG at t-th timestep. |
| $r_r(t)$ | Reserve by r-th vRES unit at t-th timestep. |
| $r_s(t)$ | Reserve by s-th storage at t-th timestep. |
| $r_{s,link}(t)$ | Reserve (power limit) by s-th storage at t-th timestep. |
| $r_{s,store}(t)$ | Reserve (energy limit) by s-th storage at t-th timestep. |
| $Rrq(t)$ | Reserve requirement at t-th timestep. |
| $w_{av,vRES}$ | Fraction of reserve needed due to vRES generation units. |
| w_{EL} | Fraction of reserve needed due to the power demand. |
| | Storage units. |
| $\eta_{disch,s}$ | Discharge efficiency of the s-th storage. |
| $e_{min,s}(t)$ | Minimum percentage state of charge of the s-th storage at t-th timestep. |
| $E_{nom,s}$ | Nominal capacity of the s-th storage. |
| $e_s(t)$ | State-of-Charge of the s-th storage at t-th timestep. |
| | vRES generation units. |
| $CF_r(t)$ | Capacity Factor related to the r-th vRES units at t-th timestep. |
| $P_{nom,r}(t)$ | Nominal power of the r-th vRES units. |
| $P_{r,av,vRES}(t)$ | Available power of the r-th vRES units at t-th timestep. |
| $P_{r,av,vRES}(t)$ | Available power of the r-th vRES units at t-th timestep. |
| $sw(t)$ | Weight of t-th timestep. |

I. INTRODUCTION

A. MOTIVATION

The global transition towards renewable energy sources (RES) is gaining momentum and the share of variable RES

(vRES) is increasing [1]. However, the intermittency and unpredictability of vRES can lead to supply fluctuations that can destabilise the grid, especially for high vRES penetration [2]. Therefore, it is necessary to develop planning methods to consider the reserve requirements, needed to cushion such fluctuations and support high RES penetration in the energy system [3].

Achieving a sustainable energy supply is particularly important for remote areas and geographical islands that are not connected to continental electricity grids [4], [5]. Many islands and remote areas are indeed electrified by large diesel generators that, to provide reserve, are often forced not to operate at maximum efficiency. However, storage and RES have recently proven able to provide reserve, hence guidelines and modelling tools for addressing the reserve provision by different technologies, conjointly with the non-linear efficiency map of fuel-fired generators are needed.

This study aims to address the increasing need to develop planning methodologies that take into account the reserve requirements for high shares of vRES in stand-alone power systems, especially on small islands. By addressing these challenges, our research aims to help achieving ambitious sustainability goals and build more resilient and sustainable energy systems.

B. LITERATURE ANALYSIS

To effectively integrate vRES into power systems, several key aspects need to be considered. These include the integration of the dispatch problem since the planning phase, including accurate operational cost models for FFGs, power reserve requirements, and the technologies capable to provide reserve power, as a compromise between model complexity and accuracy [3], [6]. These aspects are critical to ensuring system stability and reliability and are discussed in more detail in the following sections.

1) PLANNING VS. DISPATCH OPTIMIZATION: TWO DIFFERENT GOALS

The modelling complexity highly depends on its scope: short-term dispatch or long-term energy planning. Given the short-term horizon, forecasts of resources are more accurate and the smaller horizon can enable increasing complexity of the model representation [7]. Conversely, long-term planning involves determining the optimal sizing of components for a cost-effective and resilient system over a multi-year analysis period [6]. However, to appropriately estimate the overall cost of the system, dispatch consideration shall be considered within the long-term planning, that inevitably increase the total computational costs especially for long time horizon and/or high modelling details [8]. This requires a tradeoff among various factors such as the projected growth in energy demand, the availability and variability of renewable sources, and the cost and performance of different technologies, which are affected by higher uncertainty than for short-term

considerations. For example, in [9], the authors proposed a planning study that simulated the annual system with hourly time steps and considering the role of energy storage in providing reserve capacity. However, their model for FFGs was not accurate, as it did not include unit commitment and only used a simple linear model for FFGs cost. In contrast, in [10], the authors aimed to provide a model that combines short- and long-term planning methods while exploring the impact of neglecting FFG technical constraints for flexibility purposes. To handle computational complexities, representative days have often been used, however they may lead to underestimate costs. For example, authors in [6] showed that using low temporal resolution or only a few representative days will can lead to sub-optimal results. Moreover, in [11] and [12], researchers highlighted that inaccuracies also emerge when using a limited number of representative time-period in the modelling of high-RES microgrids.

The literature highlights that integrating short-term dispatch considerations into long-term planning is essential for estimating the real operating costs and reliability, especially for renewable-rich systems [3]. However, when using a short-term model in long-term planning, balancing accuracy and temporal resolution becomes challenging due to the increased complexity. Aiming to provide preliminary guidelines, in this study we test different combinations of modelling complexity, including the reserve problem and the main costs associated with FFGs (idling, start-up and shut-down).

2) FUEL-FIRED GENERATORS COST MODEL

Accurate modelling of the cost behaviour of FFGs is critical for assessing the economic feasibility of alternative technologies that can provide back-up power. Models of FFGs can - but are not limited to - include quadratic equations [13] as well as linear equations [9], [14]. In the scientific literature there are examples of studies based on piecewise-linearized quadratic models [15], while others take into account start-up and shut-down costs [10], [16], which can increase the complexity of the model. There are also examples that consider both start-up and shut-down costs as well as idling costs [17], [18] that occur when operating FFGs at null output power. These diverse approaches indicate that generator models can vary in complexity, depending on the physical system.

The modelling shall comply with the expected quality of the system representation and its multiple technologies, not only in costs but also in terms of reserve provision. However, to properly draw guidelines and practical decisions, different modelling formulations shall be compared, also considering possible contributions by all technologies. For example, the authors in [19] proposed accurate modelling of the fuel-fired generators, including start-up/shut-down costs and rump-up/down constraints, but they also limited their studies to the dispatch problem without considering the role of energy

storage in providing reserve capacity; no long-term planning was performed nor guidelines were drawn. Other studies - such as [20] and [21] - also developed accurate and non-linear cost formulations for FFGs that take into account the role of energy storage in providing reserve capacity. However, they only focused on short-term dispatch on a few days.

FFGs that provide reserve cannot operate at their maximum capacity as their spare capacity is saved for reserve provision. As a result, FFGs often operate at sub-optimal efficiency, leading to higher fuel consumption and emissions. To increase the accuracy of the planning process, we model this phenomenon by including the corresponding idling costs.

3) DEFINITION OF POWER RESERVE REQUIREMENTS

Reserve power can be divided into primary, secondary and tertiary reserve depending on how quickly they can be activated [2]. Failure to model reserve power requirements at the planning stage can lead to undersized and unreliable systems, hence causing outages and high social costs in the operation phase. Therefore, accurate modelling of reserve power requirements in planning models is crucial to ensure a resilient future energy system [3].

Various approaches to modelling reserve requirements have been proposed. Electrical load and vRES are the primary drivers of uncertainty in the energy system. Consequently, many studies focused on analyzing and quantifying reserve requirements based on these factors [19], [22]. Alternatively, some studies added a fixed quota of reserve depending on the technology providing the maximum reserve capacity, also taking into account the possibility of sudden faults [15]. Other studies also considered a maximum Rate of Change of Frequency (RoCoF) and ensured that the system design does not exceed this limit [13], [23].

However, including these requirements into planning models is a complex task, and multi-year approaches commonly neglect them [24]. For the planning problem, an integrated approach to reserve requirements was proposed by [10] that incorporates an accurate model of generator costs. However, their analysis is limited to eight representative weeks instead of performing simulations over all the hours of the year, hence potentially leading to sub-optimal solutions as highlighted in [6]. Accordingly, in this work, we propose a formulation able to account for various source of uncertainty that has also acceptable computational requirements for yearly simulation at hourly resolution.

4) TECHNOLOGIES FOR PROVIDING POWER RESERVE

Reserve needs are historically met by fuel-fired generators (FFGs) that can reliably adjust their dispatch to respond to sudden demand or supply changes, while typical vRES cannot. However, alternative technologies, such as storage, can also contribute to reserve. Integrating diverse reserve technologies is pivotal for a sustainable transition to renewable energy-based grids, while ensuring secure and reliable energy supply even with a high share of vRES [25]. The

literature is rich in papers investigating the potential reserve contribution by various technologies, like energy storage systems facilitating vRES integration [10], [21]. Flywheels [20], pumped hydro and [9] electrolyzer [26] are explored for their reserve potential. Interestingly, the authors in [19] considered the possible reserve provision by vRES, but intermittent nature limits consistent power output. In [27], the authors proposed an iterative multi-year MILP optimisation approach to microgrid planning that includes the idling cost formulation for FFGs and simplified reserve requirements. However, the study does not explicitly compare and analyze the capacity of different technologies to provide reserve, nor provides guidelines for power reserve management.

Given the lack of comprehensive guidelines for reserve requirements in microgrids and the effects of modelling into the planning results, the current paper aims to fill the gap and comprehensively investigate the possible contribution to reserve by different technologies, also performing sensitivity analyses, needed for drawing guidelines for microgrid planning.

5) COMPLEXITY OF THE MODEL

Renewable energy systems can be modeled using various mathematical techniques, including linear programming (LP), mixed-integer linear programming (MILP), and non-linear programming [28]. However, increasing the complexity of the model to enhance accuracy can lead to longer computational times, particularly at higher temporal and spatial resolutions. The inclusion of binary/integer variables to represent the flexible unit commitment and start-up and shut-down costs of fossil fuel generators transforms the problem into MILP, that significantly worsen the computational requirements [6]. The use of non-linear techniques may also be required to enforce ramp-up or ramp-down rate constraints, adding complexity to the problem. The choice of model complexity depends on the trade-off between computational time and accuracy.

To address this issue, the authors in [19] proposed a formulation of the unit commitment model that uses continuous variables to significantly speed up the simulation. Additionally, in [29] the authors proposed a mixed integer nonlinear programming (MINLP) model that optimizes the configuration of a Battery Energy Storage System (BESS) with multiple types of batteries. Finally, in [23], the authors proposed a non-linear model applied to a planning problem for full year simulations with hourly time steps. However, they did not consider the role of energy storage in providing reserve capacity. In [30], the authors proposed an efficient source-grid-storage co-planning model. It also reduced computation time by clustering flexibility resources into subgroups and adopting clustering techniques for the selection of representative days. Hence, the application of the model is limited to the simulation of short time periods.

Furthermore, various other methodologies like hybrid policy-based reinforcement learning (HPRL) or multi-energy

consensus control can also offer effective means to address these constraints, yet they are hard to consider in a planning problem [31].

When selecting a modeling method, it is crucial to consider the purpose of the study and the characteristics of the system [6]. In particular, authors emphasized that systems with high vRES penetration require higher temporal resolution and a reasonable high number of representative days to successfully capture the dynamics of the system. Accordingly, in this study, we propose a comprehensive MILP model to capture the trade-off between computational complexity and the accuracy of results in energy planning, to further drive guidelines to modelers and decision makers. In particular, attention will be paid on the conjoint impact of reserve requirements, the unit commitment and full-year energy planning problem with hourly simulation.

C. NOVELTY AND CONTRIBUTION

Previous research has identified several gaps in microgrid energy planning, especially related to guidelines on the reserve provision of different technologies (FFGs, storage and vRES) for microgrids [23], the inaccurate modeling of costs [9] and the best trade-offs for microgrid planning in hourly resolution for full-year analyses. In this regard, a comparison of the studies has been proposed in Table 1. To address these limitations, our study proposes:

- an all-inclusive approach that integrates power reserve requirements into the microgrid energy planning model, with a sensitivity on the technologies providing reserve: FFGs, storage and/or vRES;
- the inclusion of idling costs for FFGs, whose novel development has been generalized and publicly included into the PyPSA main repository [32];
- the application of the proposed methods to full year simulations with hourly time steps, to ensure results accuracy;
- an exhaustive analysis on the modelling formulation of FFGs and reserve provision, to identify tradeoffs in the quality of results and computational requirements;
- a sensitivity analysis of power reserve requirements to comprehensively investigate the resilience of the proposed method;
- policy-like recommendations for the management of power reserve in microgrid planning.

The proposed methodology is applied to the Italian small island of Pantelleria, which experiences significant fluctuations in electrical load due to tourism. By applying our methodology to such a challenging case-study, our study sheds light on important issues that have practical implications for energy planning in microgrids.

D. STRUCTURE OF THE WORK

Our work is structured as follows. Section II presents the methodology used for the analysis and its mathematical formulation is presented in Section III. Section IV presents

TABLE 1. Analysis of the model previously proposed in literature with respect the patterns addressed by this work.

| Ref. | Goal | Idling costs | Start-up cost | Techs for reserve | | | Network size | Full Year | Policy guidelines |
|-----------|------|--------------|---------------|-------------------|------|---------|--------------------|-----------|-------------------|
| | | | | FFG | vRES | Storage | | | |
| [2] | S | | | ✓ | | | Microgrid | | |
| [9] | P | | | ✓ | | ✓ | National | ✓ | ✓ |
| [10] | P | ✓ | ✓ | ✓ | | ✓ | National | | |
| [11] | P | | | | | | Microgrid | | ✓ |
| [12] | P | | | | | | Microgrid | | ✓ |
| [13] | P | ✓ | ✓ | ✓ | | ✓ | Microgrid | | |
| [14] | P | | | ✓ | | | Microgrid | ✓ | Partially |
| [15] | S | ✓ | ✓ | ✓ | | | National | | |
| [16] | S | | ✓ | ✓ | | ✓ | IEEE 118-bus | | |
| [17] | P | | ✓ | ✓ | | | IEEE 39/57/118-bus | | |
| [18] | S | ✓ | ✓ | ✓ | | ✓ | National | ✓ | ✓ |
| [19] | S | ✓ | ✓ | ✓ | ✓ | | National | ✓ | Partially |
| [20] | S | ✓ | ✓ | | | ✓ | IEEE 118-bus | | |
| [21] | S | ✓ | ✓ | ✓ | | ✓ | National | | ✓ |
| [22] | P | | ✓ | ✓ | | ✓ | NREL 118-bus | | |
| [23] | P | ✓ | ✓ | ✓ | | | National | ✓ | |
| [24] | P | | | | | | Microgrid | | ✓ |
| [25] | P | | ✓ | ✓ | | ✓ | National | | Partially |
| [27] | P | ✓ | | ✓ | | ✓ | Microgrid | | |
| [30] | P | | ✓ | ✓ | | | National | | |
| This work | P | ✓ | | ✓ | ✓ | ✓ | Microgrid | ✓ | ✓ |

the case study, outlining the main features of the stand-alone system considered for the simulations carried out. The results of the simulation are presented and discussed in Section V. Finally, conclusions are drawn in Section VI.

II. METHODOLOGY

In this section, we detail the novel approach to design isolated power systems while coping with reserve requirements and appropriate dispatch of the assets. The methodology focuses on planning systems with arbitrary different sources of vRES (e.g. wind, solar, and/or hydro), FFGs and different storage technologies, while the corresponding mathematical formulation is denoted in Section III. In particular, for the considered system we investigate different modelling approaches, as detailed as follows:

- 1) propose the mathematical formulation of an accurate cost model for FFGs, power reserve requirements, provision of power reserve by FFGs, storage and vRES technologies;
- 2) propose different modelling representations, gradually introducing the following features:
 - a) FFG committability and minimum rate power;
 - b) idling cost for FFG;
 - c) reserve requirements satisfied by FFGs alone;
 - d) the role of storage in providing reserve;
 - e) the integration of vRES in providing reserve.

These features are integrated in accordance with the methodology flowchart proposed in Figure 1.

It is worth noting that by adding each feature in point 2 step by step, we consider all possible combinations (10 different scenarios, summarised in Table 2) to explore the interdependence of factors relevant to energy planning for standalone systems. This is aimed at exploring how modelling these phenomena in an all-inclusive model affects energy planning for standalone systems. The following section will detail the mathematical formulation of the proposed approach.

III. MATHEMATICAL FORMULATION

This section is organized as follows. Firstly, we present the objective function and the adopted model for the cost of FFGs. Next, we describe the equations that define the reserve requirements and how they are modeled in the proposed framework. Subsequently, we discuss the equations that model the participation of dispatchable generators in providing reserve, followed by the equations that model the participation of BESS in reserve provision. Finally, we present the equations that model the participation of vRES in reserve provision. The mathematical formulations presented in this paper are implemented in the PyPSA framework [33]; the novel feature of the idling cost has also been integrated in the official PyPSA repository.

A. OBJECTIVE FUNCTION

The economic objective function adopted for the optimization of the proposed model consists in the Net Present Cost (NPC) of the power system, described in (1)-(4): it considers the

TABLE 2. Setting of the proposed case studies. ‘BS’ denotes the base scenario, while ‘SR’ indicates scenarios with reserve. Each scenario is also identified by abbreviations representing different features, such as FFGs committability, minimum power rate, idling cost, and power reserve sources.

| Case Study | FFGs features | | | Power reserve model | | |
|------------------------------------|----------------|----------------------|------------------|----------------------|---------------------------|---------------------------|
| | Committability | Min. rate power (Mr) | Idling cost (Ic) | FFGs provide reserve | BESS provides reserve (B) | vRESs provide reserve (V) |
| Base Scenario (BS) | | | | | | |
| BS:Mr | X | X | | | | |
| BS:Ic | X | | X | | | |
| BS:MrIc | X | X | X | | | |
| Scenarios with Reserve (SR) | | | | | | |
| SR:Mr | X | X | | X | | |
| SR:Ic | X | | X | X | | |
| SR:MrIc | X | X | X | X | | |
| SR:MrIc-V | X | X | X | X | | X |
| SR:MrIc-B | X | X | X | X | X | |
| SR:MrIc-BV | X | X | X | X | X | X |

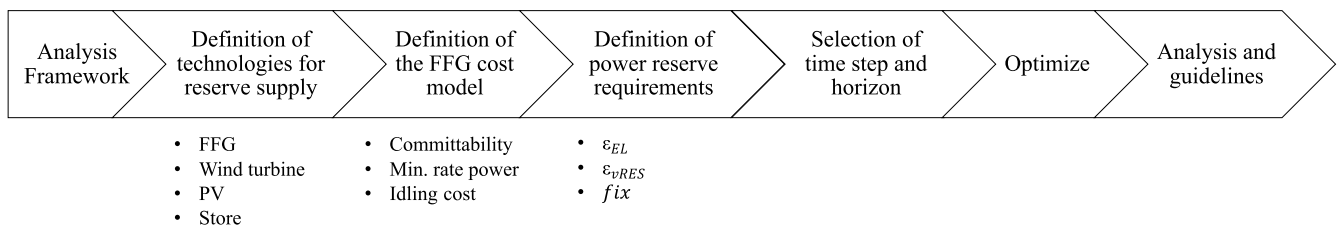

FIGURE 1. Flowchart of the methodology used to integrate the model patterns.

capital and operational cost of vRES techs, energy storage, and FFGs. Its formulation accounts for the total annualized capital costs CC_{tot} , the total operational cost OC_{tot} , and the weighting of the t-th snapshot.

$$\min f_{obj}^{base} = \min \{CC_{tot} + OC_{tot}\} \quad (1)$$

$$CC_{tot} = \sum_{g=1}^{\Omega_G} cc_g \cdot P_{nom,g} + \sum_{r=1}^{\Omega_R} cc_r \cdot P_{nom,r} \quad (2)$$

$$+ \sum_{s=1}^{\Omega_S} cc_s \cdot E_{nom,s} + cc_{s,links} \cdot P_{nom,s} \quad (3)$$

$$OC_{tot} = \sum_{t=1}^{t_{end}} sw(t) \cdot \left(\sum_{g=1}^{\Omega_G} oc_g \cdot d_g(t) + \sum_{s=1}^{\Omega_S} oc_s \cdot d_s(t) \right) \quad (4)$$

B. FFGS COST MODEL EQUATIONS

The objective function proposed in (1) is expanded, including an extra cost term to account for idling cost for FFGs, when they are turned on. This term is presented in (5), where $f_{e,g}$ is the extra term of the objective function due to the g-th FFGs, t_{end} is the number of snapshots considered, $sw(t)$ is the weight of the t-th snapshot, $s_g(t)$ is the status of the g-th FFGs at the t-th time step, and Ic_g is the idling cost of the g-th FFGs.

$$f_{e,g} = \sum_{t=1}^{t_{end}} s_g(t) \cdot Ic_g \cdot sw(t), \quad \forall g \in \Omega_G \quad (5)$$

The normalisation of Ic_g can be achieved by dividing by the nominal power of the i-th FFG ($P_{nom,g}$), as depicted in (6).

Here, ic is the specific idling cost, which may vary with the nominal power. In the case study considered in this study, ic is a fixed value, and further details are provided in Section IV-E.

$$f_{e,g} = \sum_{t=1}^{t_{end}} s_g(t) \cdot ic \cdot P_{nom,g} \cdot sw(t), \quad \forall g \in \Omega_G \quad (6)$$

In addition, it is worth noting that the idle cost term can also account for generator degradation and maintenance, as they depend on the actual operating hours. This approach is taken in the case study presented in this paper, where the specific idling cost was obtained from the catalogs of the generators in the microgrid. The derived cost was then added to the degradation cost.

Lastly, in (7) the complete formulation of the objective function adopted is presented, where the extra term is added to the total capital and operation cost.

$$f_{obj} = f_{obj}^{base} + \sum_{g=1}^{\Omega_G} f_{e,g}, \quad \forall g \in \Omega_G \quad (7)$$

The code related to the mathematical formulation described in this paragraph is available on GitHub and has been merged into the main branch of the PyPSA repository [32].

C. RESERVE REQUIREMENTS

Following the approach suggested in [9] and [10], our power reserve requirements model takes into account the uncertainty associated with the electric load and vRES availability. To calculate the reserve requirement for a microgrid,

we incorporate the electric load and vRES availability using two terms: w_{EL} and $w_{av,vRES}$. The specific parameters chosen for the case study presented in this paper are discussed in the relevant section. Moreover, a fixed term is also included to account for the uncertainty associated with possible faults of the assets of the system. Different approaches can be used to determine this term, such as considering the maximum or minimum-sized generator connected to the grid, a fixed value, or the maximum generator operating at the considered time. For the case study considered in this paper, the smallest generator size is used. However, a sensitivity analysis is performed in the results section by incrementally increasing the reserve demand up to 50% in four steps.

The power reserve requirement at the t -th time step is then given by (8), where $EL(t)$ is the electrical load demanded at the t -th time step, $P_{r,avvRES}(t)$ is the power available at the t -th time step for the r -th vRES technology, and fix is the fixed term, whose value can vary depending on the specific case study being considered, as expressed in (9). The variable r represents the r -th vRES technology.

$$R_{rq}(t) = w_{EL} \cdot EL(t) + \sum_r w_{av,vRES} \cdot P_{r,avvRES}(t) + fix \quad (8)$$

$$fix = \min\{P_{nom,g}\}, \quad g \in \Omega_G$$

$$fix = \max\{P_{nom,g}\}, \quad g \in \Omega_G$$

$$fix = q, \quad q > 0 \text{ MW} \quad (9)$$

The power available for the r -th vRES technology at the t -th time step $P_{r,avvRES}(t)$ is defined as in (10), where $CF_r(t)$ is the capacity factor, $P_{max,r}$ is the nominal power (output of the optimization), and r stays for the r -th vRES technology.

$$P_{r,avvRES}(t) = CF_r(t) \cdot P_{nom,r}, \quad \forall r \in \Omega_R \quad (10)$$

D. FFG PARTICIPATION IN RESERVE SUPPLY EQUATIONS

The power reserve provided by the g -th FFG at time-step t corresponds to the available power, which is the amount of power that can be delivered within a few minutes after the generator is accelerated. This available power is calculated as the difference between the output of the i -th generator when it is turned on and the power supplied to meet the electrical demand, as shown in (11).

$$r_g(t) \leq P_{nom,g} \cdot s_g(t) - d_g(t), \quad \forall g \in \Omega_G \quad (11)$$

Considering the case of power reserve provided by FFGs only, the reserve constraint to be respected is represented by (12).

$$\sum_{g=1}^{\Omega_G} r_g(t) \geq R_{rq}(t) \quad (12)$$

E. BESS PARTICIPATION IN RESERVE SUPPLY EQUATIONS

The available power reserve of a BESS at the t -th time step is limited by two main factors: the energy and power constraints of the BESS. The first factor is modelled using the state of charge of the BESS, which must be maintained within a

certain range to prevent overcharging or discharging beyond the recommended level.

Equations (13) and (14) limit the available discharge power of the BESS based on its state of charge at the previous time step and the current time step, respectively. In equation (13), $r_{s,store}(t)$ represents the available discharge power for storage unit s at time t , $\eta_{disch,s}$ is the round-trip efficiency of the BESS, $e_s(t-1)$ is the state of charge of the BESS at the previous time step, and $E_{nom,s}$ and $e_{min,s}(t)$ represent the nominal capacity and minimum state of charge percentage, respectively. In equation (14), $e_s(t)$ represents the state of charge of the BESS at the current time step.

$$r_{s,store}(t) \leq \eta_{disch,s} \cdot (e_s(t-1) - E_{nom,s} \cdot e_{min,s}(t)), \quad \forall s \in \Omega_S \quad (13)$$

$$r_{s,store}(t) \leq \eta_{disch,s} \cdot (e_s(t) - E_{nom,s} \cdot e_{min,s}(t)), \quad \forall s \in \Omega_S \quad (14)$$

The second factor limiting the available power reserve is the rated power of the power electronics converter, taken into account by (15). In (15), $r_{s,link}(t)$ represents the available power from the converter of storage unit s at time t , $P_{nom,s}$ is the rated power of the converter, and $d_s(t)$ is the actual power output from the converter at time t . Note that the dispatch of each storage unit s is regulated by a corresponding converter.

$$r_{s,link}(t) \leq P_{nom,s} - d_s(t), \quad \forall s \in \Omega_S \quad (15)$$

The maximum available power reserve for each BESS is determined by selecting the minimum value between the power limits imposed by the state of charge and the converter. Equation (16) represents this by selecting the maximum available power reserve of storage unit s at time t , denoted by $r_s(t)$.

$$r_s(t) \leq \min\{r_{s,store}(t), r_{s,link}(t)\}, \quad \forall s \in \Omega_S \quad (16)$$

To ensure that the total power reserve supplied by all BESSs and FFGs is greater than or equal to the reserve requirement at each time step (defined in (8)), (17) is used.

$$\sum_{g=1}^{\Omega_G} r_g(t) + \sum_{s=1}^{\Omega_S} r_s(t) \geq R_{rq}(t) \quad (17)$$

F. vRES PARTICIPATION IN RESERVE SUPPLY EQUATIONS

In this section, we describe the model for the participation of vRES in the provision of reserve in power systems. Nowadays, vRES technologies face significant technical and practical limitations in providing reserve. However, accounting for their contribution within the planning phase is required to draft guidelines on reserve requirements and to enable further research targeted at increasing their reserve provision.

The model for the participation of vRES in the provision of reserve is mainly defined by (18). It imposes a limit on the maximum reserve that can be provided by vRES technologies at any given time. This limit is equal to the available resource

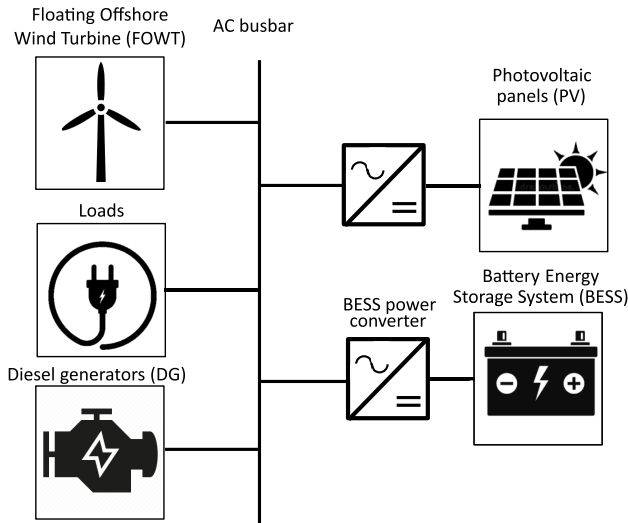

FIGURE 2. Microgrid architecture.

for each vRES technology, less the power already dispatched by the technology at the same time.

$$r_r(t) \leq CF_r(t) \cdot P_{nom,r} - d_r(t), \quad \forall r \in \Omega_R \quad (18)$$

In (19), the reserve requirement that must be met when reserve is provided by both FFGs and vRES technologies is specified. Conversely, if BESS are also providing reserve, (20) describes the total reserve requirement that must be met.

$$\sum_{g=1}^{\Omega_G} r_g(t) + \sum_{r=1}^{\Omega_R} r_r(t) \geq R_{rq}(t) \quad (19)$$

$$\sum_{g=1}^{\Omega_G} r_g(t) + \sum_{s=1}^{\Omega_S} r_s(t) + \sum_{r=1}^{\Omega_R} r_r(t) \geq R_{rq}(t) \quad (20)$$

IV. CASE-STUDY

A. DESCRIPTION

The Island of Pantelleria, located in the Strait of Sicily, is a remote and non-interconnected small island with an extension of 85 km², a stable population of 7700 inhabitants and very large tourist flows during summer. It is an ideal case study for exploring local energy self-sufficiency through the application of a microgrid energy planning model, given its abundance of solar and wind resources due to its favorable location.

Accordingly, the energy model in this study is composed by Lithium-ion Energy Storage (Li-ES), Photovoltaic (PV) and Floating Offshore Wind Turbines (FOWT), and diesel generators (DGs) (see Figure 2). Notably, the maximum PV capacity was limited to 15 MW, while onshore wind turbines are excluded due to local legal restrictions [34]. The investment and operating costs associated with the adopted RES technologies are presented in Table 3. A discount rate of 5% is assumed [35].

The existing island’s energy system relies on eight DGs with a total installed capacity of 25 MW. The cost of diesel

TABLE 3. Cost assumptions related to RES technologies. Note that y stays for years.

| Technology | CapEx | OpEx | Op. Lifetime | Ref. |
|-----------------|------------------------------------|--|--------------|------------|
| PV | 905 $\frac{\text{€}}{\text{kW}}$ | 17 $\frac{\text{€}}{\text{kW}\cdot\text{y}}$ | 25 years | [36], [37] |
| FOWT | 4,500 $\frac{\text{€}}{\text{kW}}$ | 94 $\frac{\text{€}}{\text{kW}\cdot\text{y}}$ | 25 years | [38] |
| Li-ES | 300 $\frac{\text{€}}{\text{kWh}}$ | 6 $\frac{\text{€}}{\text{kWh}\cdot\text{y}}$ | 15 years | [39] |
| Power Converter | 180 $\frac{\text{€}}{\text{kW}}$ | 18 $\frac{\text{€}}{\text{kW}\cdot\text{y}}$ | 15 years | [39] |

is described in Section IV-E, where the sizes of the eight generators are also detailed. The load profiles and all the information regarding the DGs used in this study are provided by the local Distribution System Operator (DSO). The annual electricity demand in 2019 was about 37 GWh [40], with a peak load of 9.5 MW and a base load of 2.2 MW. The local solar and wind energy production data are collected through the ERA5 web platform [41]. The wind power resources have an average capacity factor of 40%, while the solar photovoltaic resources have an average capacity factor of 19%. Concerning the Li-ES system, the following assumptions have been applied:

- the round-trip efficiency equals to 90%, equally divided between charge and discharge [42];
- the c-rate has been assumed equals to 1, with a minimum duration of 2 hours, where the minimum duration is defined as the time taken by the battery to discharge completely, providing a power equal to the power converter capacity [43];
- the degradation cost of Li-ES has been assumed equal to 0.3 €/kWh, obtained considering 10,000 lifetime cycles [44].
- The SoC of the Li-ES system has been assumed to be balanced, meaning that the initial and final SoC levels are forced to match in every simulation.

B. PROCEDURE

The reserve requirements are set by the parameters w_{EL} , $w_{av,vRES}$ and fix (as described in Eq. (8)), which correspond respectively to the load-dependent share of the reserve, the vRES-dependent share and the minimum fixed reserve requirement, respectively. The proposed simulations can be divided into three different groups, as follows.

1) ANALYSIS OF THE MODELLING FORMULATIONS

Initially, these parameters (w_{EL} , $w_{av,vRES}$ and fix) are set in order to establish a curve for the requirement of reserve power. Simulations are then carried out for four representative weeks, using these predefined values. These simulations are carried out for the scenarios outlined in Table 2, which allows an analysis of the effects of the different modelling formulations. The scenarios in Table 2 are gradually introducing different features to encompass all possible combinations and to determine the mutual influence of the modelled phenomena on the results.

2) FULL-YEAR SIMULATIONS

Once the reciprocal influence is analyzed, simulations are carried out for a complete year for the five main cases: the base scenario (BS:MrIc) with full FFG cost model implemented (committability, minimum rate power and idling cost), and the four reserve cases (reserve provided by FFG only, reserve provided by FFG and vRES, reserve provided by FFG and BESS, and reserve provided by FFG, BESS, and vRES). These simulations aim to assess the contribution of BESS to power reserve supply and investigate how their integration in long-term energy planning impacts the optimal sizing of microgrid components. Additionally, the simulations explore how the dispatch strategy of FFGs may vary when different technologies are involved in providing power reserve.

3) SENSITIVITY ANALYSIS ON RESERVE PARAMETERS

The reserve parameters (w_{EL} , $w_{av,vRES}$, and fix) are progressively increased to create four distinct power reserve requirement settings, with a percentage increase up to a 265% (Rq1, Rq2, Rq3, and Rq4 - numerically defined in III-C). The simulations are then re-run for the representative 4-weeks period to perform a sensitivity analysis. This sensitivity analysis helps to evaluate how much the optimal nominal capacities of RES technologies are sensitive to changes in the reserve request.

C. SIMULATION TOLERANCE SETTINGS

The model is solved using the CPLEX solver V20.1.1 [45] on a machine equipped with an AMD Ryzen 9 3900X processor and 64 GB of RAM. The simulations are performed for both a representative 4-weeks period and the entire year, with maximum gap tolerances no higher than 5% [27], depending on the case to prevent unacceptable computational requirements. The convergence and effective tolerances are tracked and reported in the Results section.

D. RESERVE REQUIREMENTS

The model of the reserve described in Section III-C is based on three main parameters related to the contributions due to the electrical demand (w_{EL}), the available power from vRES ($w_{av,vRES}$) and the possible outages of components (fix).

In literature, $w_{av,vRES}$ is generally considered equal to 10% for case studies with similar size and characteristics [46]. However, w_{EL} varies from 10% to 30% [47], [48], and the fixed term fix , as defined in (9), can be modelled in different ways: the authors of [9] and [46], for example, proposed to calculate it based on the maximum FFG available to the power grid, while [19] only considers percentage weights and sets the fixed term to 0 MW.

Given these variability, as introduced above, we propose a sensitivity analysis on the reserve requirements. We define four different sets of parameters, denoted as Rq1, Rq2, Rq3 and Rq4 and summarised in Table 4. Rq1 is used as the

TABLE 4. Power Reserve requirements settings.

| Abbr. | $w_{av,vRES}$ | w_{EL} | fix |
|-------|---------------|----------|---------------------|
| Rq1 | 10% | 10% | $\min\{P_{max,g}\}$ |
| Rq2 | 10% | 20% | $\min\{P_{max,g}\}$ |
| Rq3 | 10% | 30% | $\min\{P_{max,g}\}$ |
| Rq4 | 10% | 30% | $\max\{P_{max,g}\}$ |

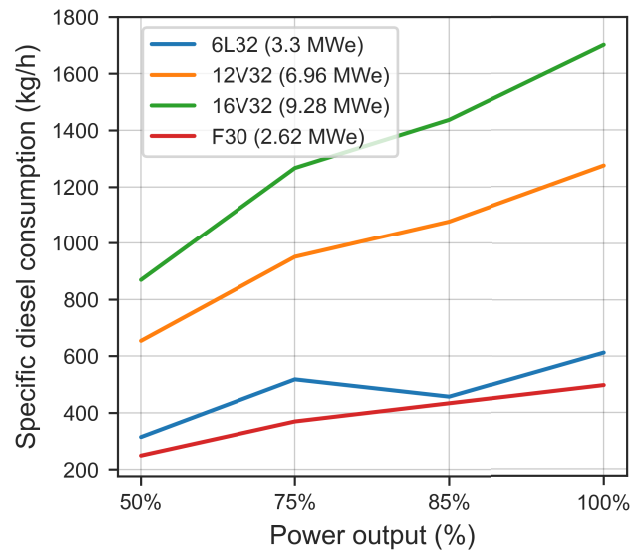

FIGURE 3. Specific diesel generators consumption curves.

baseline scenario, which is considered appropriate based on the literature analysis and to the authors' best knowledge.

E. DIESEL GENERATORS

In order to characterize the cost model proposed for DGs in Section III-B, a selection of cost parameters is necessary: idling cost (ic) (related to stand-by diesel consumption), and marginal cost (related to marginal diesel consumption). Based on the datasheets of generators provided by the local DSO (reported in Section A), it can be observed that the power grid of Pantelleria Island relies on eight diesel generators with nominal powers ranging from 1.2 MW to 5.3 MW.

The literature provided consumption curves of generators that can be associated with those installed in Pantelleria [49], [50]. The parameters of the DGs associated with the ones actually installed are reported in Section A and the different operating curves are shown in Figure 3. The graph shows how the behaviour is almost always linear, with a non-negligible fixed term (idling consumption). For this reason, a linear trend (with a fixed term) is assumed to model the behaviour of the DGs. Following this assumption, the operating curves of the four selected DGs are interpolated and the coefficients of the associated linear interpolation lines are also reported in Section A, as well as the fixed term normalised to its respective nominal power.

The normalised parameter and the marginal consumption are then averaged, and with a specific fuel cost of 1.885 €/l (obtained from the average net cost of diesel in Italy in

TABLE 5. Setting parameters of the FFG.

| Info. | Value | Ref. |
|--------------------|---|--------------------------|
| Specific fuel cost | 1.885 €/l | ref. to Italy 2022 [51]) |
| Fuel density | 0.835 kg/l | - |
| Marginal cost | $8.5 \frac{\text{€}}{\text{h} \cdot \text{MW}}$ | IV-E |
| Idling cost | $406 \frac{\text{€}}{\text{MW} \cdot \text{h}}$ | IV-E |
| Degradation | $10 \frac{\text{€}}{\text{h} \cdot \text{MW}}$ | [52], [53] |
| Lifetime | 20,000 hours | [52], [53] |
| Capital cost | $200,000 \frac{\text{€}}{\text{MW}}$ | [54] |
| Maintenance cost | $50 \frac{\text{€}}{\text{h} \cdot \text{MW}}$ | [54] |
| Load minimum rate | 10% | - |

2022 [51]) and a density of 0.835 kg/l. All the other setting parameters are reported in Table 5.

V. RESULTS AND DISCUSSIONS

In this chapter we present and discuss the results of the simulations carried out as discussed in Section IV-B.

A. PERFORMANCE COMPARISON OF MODELLING FORMULATION OF FUEL GENERATORS AND RESERVE

The effect of different modelling formulation into the simplified microgrid is reported in Table 6, where every row corresponds to the cases described in Table 2 with a 4 representative weeks (4W) time horizon representation and reserve requirements corresponding to 10% of the demand and of the available vRES production (Rq1 case). Table 6 reports the major computational results, the value of the objective function, the optimal size of the assets and a summary of the microgrid dispatch. It is worth mentioning that the objective function f_{obj}^{base} of the cases BS, BS:Mr and SR:Mr does not account for the idling cost, hence it is shown as a separate value but, for comparison purposes, the equivalent value of f_{obj} that accounts for the idling costs is also calculated.

The results in Table 6 show that the introduction of the idling costs plays may lead to underestimate costs up to 30% (f_{obj} and f_{obj}^{base} in SR:Mr). Furthermore, if idling costs are included in the model formulation, annualised system costs (f_{obj}) decrease by 4% compared to the full objective function (from BS to BS:Ic). On the other hand, the inclusion of the minimum rate power has no impact in the BS case, whereas when reserve constraints are included (SR cases), they may affect up to 10% of the total system costs in the scenarios where storage cannot provide reserve. The introduction of power reserve requirements in the modelling increases the total costs by up to 27.7%. In SR:Ic, the DGs are operated for over 60% of the time at nearly no output ($< 0.01\text{MW}$) just to meet the reserve requirements. In SR:MrIc, costs increase by more than 25% to meet the power reserve as DGs need to be operated more frequently at lower load factor, hence compromising efficiency. However, when BESS can provide reserve (SR:MrIc-B and SR:MrIc-BV cases), the power reserve requirements have little impact in the final results. Indeed, the economic optimization leads to sizing a large BESS system that in the operation has

naturally spare power capacity that can serve as power reserve. The larger BESS allows to account for the additional constraints in SR scenarios than in the corresponding BS ones. Therefore, on the one hand, including idling costs and reserve requirements is crucial to perform an optimal stable energy system. The effect of minimum power rate of DGs, on the other hand, may lead to overestimation of the benefits by DGs. However, when BESS can provide reserve, DGs are operated at highest efficiency and reserve is mostly provided by BESS; in this condition, the modelling impact of the minimum power rate of DGs is negligible, hence modellers may decide to approximate these constraints to reduce computational complexity.

The optimal sizing of the system is also affected by the modelling formulation. The inclusion of idling costs leads to a larger storage size and a lower number of DG working hours (-14% in SR:MrIc with respect to SR:Mr). In contrast to cases without reserve requirements (BS:Ic and SR:MrIc), the inclusion of minimum rate power is crucial when power reserve formulation is considered (see scenarios SR:Ic and SR:MrIc): it strongly affects the share of vRES and the behavior of DGs. The overall sizing of renewable sources is slightly affected: due to land limitation all photovoltaic panels are always installed and the wind plant is increased when idling costs are considered. The wind generation is further increased when vRES are allowed to provide reserve contrary to BESS. On the other hand, when BESS can provide reserve (e.g. SR:MrIc-BV), the optimal sizing of the vRES matches the results of the modelling without reserve requirements.

Overall the computational complexity does not exceed 1.3 hours for a 4-week case study, with the longest optimization being related to the scenario with the minimum power rate of DGs and idling cost model (SR:MrIc). Due to the combinatorial nature of unit commitment problems, that formulation (SR:MrIc) is computationally hard to solve, but when BESS can provide reserve, then the solution is achieved faster. Therefore, this study suggests that the use of reserve requirements in BESS-rich problems is not expected to increase significantly the computational requirements, and it is hence recommended, also to increase the robustness of the system, provided an appropriate local control system.

B. FULL-YEAR SIMULATION: TOTAL ANNUAL COST VS. FOSSIL FUEL CONSUMPTION

The most relevant scenarios from the 4-weeks analyses in Table 6 are fully optimized using full year (FY) representation and the full DGs model (committability, minimum rate power and idling cost) are shown in Table 7. A focus on the system costs, environmental impact and reserve provision is depicted in Figure 4, whereas Figure 5 highlights the specific increase in fuel consumption and total costs, with respect to the BS:MrIc scenario.

To highlight the impact of the modelling formulations on the results, Figure 4 denotes the major trade-offs between overall system costs, environmental impact and reserve provision, whereas Figure 5 highlights the specific increase

TABLE 6. Optimization results of the 10 scenarios carried out over 4 representative weeks (4W) with reserve requests set to Rq1. Note that f_{obj} , as defined in (7), represents the optimized function for all scenarios except those that do not consider the idling costs of DGs (scenarios BS, BS:Mr, and SR:Mr). In such cases, the optimized function corresponds to f_{obj}^{base} , and the reported value of f_{obj} (which includes the idling costs) is computed during the post-processing.

| Scenario | Time horizon | Reserve requir. | End Toll. | Comp. time (s) | f_{obj}^{base} (M€) | f_{obj} (M€) | Optimal size of components | | | | Share RES (%) | Hours with reserve satisfied by: | | Diesel generators | | | | Fuel (kl) |
|------------|--------------|-----------------|-----------|----------------|-----------------------|----------------|----------------------------|-----------|------------|-----------------|---------------|----------------------------------|----------|-------------------|---------------------|--------------------|----------------|-----------|
| | | | | | | | PV (MW) | FOWT (MW) | BESS (MWh) | BESS conv. (MW) | | DGs | DGs+BESS | Work. hours (h) | Avg. DGs "on" (#/h) | Max DGs "on" (#/h) | Load fact. (%) | |
| BS | 4W | Rq1 | 0.00% | 1 | 7.12 | 7.99 | 15.00 | 3.71 | 28.03 | 6.10 | 79.8% | 83 | 454 | 337 | 0.50 | 4 | 71% | 132 |
| BS:Mr | 4W | Rq1 | 0.00% | 1 | 7.12 | 8.02 | 15.00 | 3.74 | 28.04 | 6.10 | 79.9% | 102 | 482 | 403 | 0.60 | 4 | 47% | 132 |
| Bs:Ic | 4W | Rq1 | 0.85% | 4 | - | 7.68 | 15.00 | 4.17 | 32.68 | 6.31 | 81.6% | 2 | 442 | 203 | 0.30 | 3 | 97% | 119 |
| Bs:MrIc | 4W | Rq1 | 0.86% | 5 | - | 7.68 | 15.00 | 3.99 | 31.35 | 6.19 | 81.0% | 0 | 499 | 196 | 0.29 | 3 | 95% | 122 |
| SR:Mr | 4W | Rq1 | 0.82% | 291 | 7.68 | 10.20 | 15.00 | 3.28 | 28.69 | 5.78 | 75.6% | 672 | 672 | 1117 | 1.66 | 8 | 24% | 167 |
| SR:Ic | 4W | Rq1 | 0.98% | 507 | - | 8.99 | 15.00 | 3.56 | 30.31 | 6.28 | 80.0% | 672 | 672 | 848 | 1.26 | 3 | 19% | 136 |
| SR:MrIc | 4W | Rq1 | 1.99% | 4649 | - | 9.69 | 15.00 | 3.28 | 31.05 | 6.39 | 76.0% | 672 | 672 | 915 | 1.36 | 3 | ero 25% | 161 |
| SR:MrIc-V | 4W | Rq1 | 0.88% | 101 | - | 8.63 | 15.00 | 5.43 | 26.38 | 5.33 | 81.0% | 229 | 577 | 511 | 0.76 | 4 | 36% | 125 |
| SR:MrIc-B | 4W | Rq1 | 0.96% | 14 | - | 7.75 | 15.00 | 4.15 | 33.43 | 6.28 | 81.5% | 6 | 672 | 183 | 0.27 | 3 | 86% | 119 |
| SR:MrIc-BV | 4W | Rq1 | 0.80% | 6 | - | 7.73 | 15.00 | 4.15 | 32.42 | 6.31 | 81.4% | 9 | 663 | 202 | 0.30 | 3 | 88% | 120 |

TABLE 7. Simulation results of the 5 scenarios conducted over the full year (FY) with hourly time step with reserve requests set to Rq1.

| Scenario | Time horizon | Reserve requir. | End Toll. | Comp. time (s) | f_{obj} (M€) | Optimal size of components | | | | Share RES (%) | Hours with reserve satisfied by: | | Diesel generators | | | | Fuel (kl) |
|------------|--------------|-----------------|-----------|----------------|----------------|----------------------------|-----------|------------|-----------------|---------------|----------------------------------|----------|-------------------|---------------------|--------------------|----------------|-----------|
| | | | | | | PV (MW) | FOWT (MW) | BESS (MWh) | BESS conv. (MW) | | DGs | DGs+BESS | Work. hours (h) | Avg. DGs "on" (#/h) | Max DGs "on" (#/h) | Load fact. (%) | |
| BS:MrIc | FY | Rq1 | 1.47% | 1310 | 7.33 | 15.00 | 4.04 | 37.58 | 6.98 | 83.8% | 26 | 7118 | 2778 | 0.32 | 3 | 93% | 131 |
| SR:MrIc | FY | Rq1 | 4.68% | 37116 | 9.29 | 15.00 | 2.40 | 38.79 | 7.49 | 76.9% | 8760 | 8760 | 11978 | 1.37 | 5 | 28% | 195 |
| SR:MrIc-V | FY | Rq1 | 1.77% | 3977 | 8.32 | 15.00 | 5.04 | 34.90 | 7.00 | 83.6% | 3743 | 8128 | 7320 | 0.84 | 4 | 35% | 137 |
| SR:MrIc-B | FY | Rq1 | 1.91% | 5256 | 7.41 | 15.00 | 3.92 | 39.41 | 8.24 | 83.7% | 91 | 8760 | 2866 | 0.33 | 4 | 88% | 131 |
| SR:MrIc-BV | FY | Rq1 | 1.39% | 6218 | 7.37 | 15.00 | 3.86 | 39.63 | 7.17 | 83.7% | 65 | 8397 | 2814 | 0.32 | 3 | 92% | 132 |

in fuel consumption and total costs, with respect to the BS scenario. The results confirm the considerations of the 4-week representation and highlight that the overall computational complexity of the cases with BESS is acceptable for energy planning purposes. When reserve shall be provided by DGs-only, however, computational requirements increases significantly.

The scatter plot in Figure 4 illustrates the trade-off between system costs and environmental impacts (quantified in terms of fuel consumption). The results show that including BESS in the provision of power reserve leads to a significant reduction in annual costs of around 20% and an impressive 35% reduction in fuel consumption. Moreover, when DGs and vRES techs provide reserve, results outperform the case without vRES in the power reserve supply (-10% annualized system cost and -39% fuel consumption). However, when BESS provide reserve, the contribution of vRES to the overall reserve becomes negligible.

The bar plot in Figure 5 illustrates the impact of power reserve requirements on annualised costs and fuel consumption in four different scenarios, with respect to the case without power reserve requirements (BS:MrIc). The results show that the provision of power reserve requirements has a significant impact on the annualised costs (+25%) and fuel consumption (+50%).

These results highlight that when the energy reserve is provided by BESS, total cost and fuel consumption are comparable to the case without reserve provision. This indicates that by implementing appropriate control strategies that enable BESS to provide reserve, the system can be both robust and efficient, and that it is important to consider power reserve requirements since the design phase.

C. STATISTICS ON THE POWER RESERVE MANAGEMENT

The stacked bar chart in Figure 6 illustrates the power reserve provided by different technologies in various scenarios:

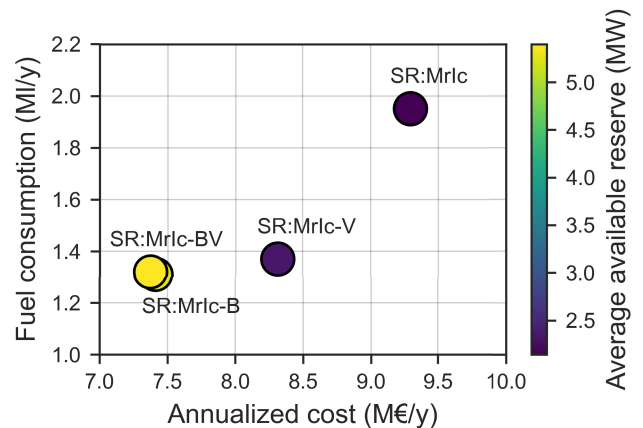

FIGURE 4. This scatter plot compares the annualized cost of different energy systems with their respective fossil fuel consumption and power reserve supply. The power reserve supply definition varies according to the different scenarios analyzed, as shown in Table 2.

only DGs (SR:MrIc), DGs and vRES (SR:MrIc-V), DGs and BESS (SR:MrIc-B) and all technologies (SR:MrIc-BV). The solid colors in Figure 6 denote the actual reserve that is considered, in agreement to the technologies providing reserve. For the sake of improving the comparison of results, we also denote in transparent color the possible spare reserve that may be provided by BESS or vRES, if the appropriate control system had been installed.

It is worth noting that the reserve provided by DGs drops in the last two scenarios in Figure 6. In those scenarios, DGs are efficiently operated in an on-off mode, thus working at their highest efficiency, and BESS provides the required reserve. Also, the reserve contribution by BESS in the last two scenarios is nearly twice as much as the (unexploitable) potential reserve that BESS may have provided in the SR:MrIc case. Such large increase is not matched with a

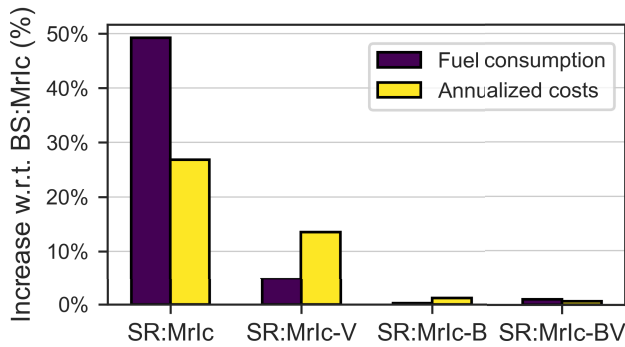

FIGURE 5. Percentage increase in total fuel consumption and annualized system cost due to power reserve supply requirements in four different scenarios. Percentage increased is referred to the annualized system cost and total fuel consumption of the scenario BS:MrIc, according to the definition provided in Table 2.

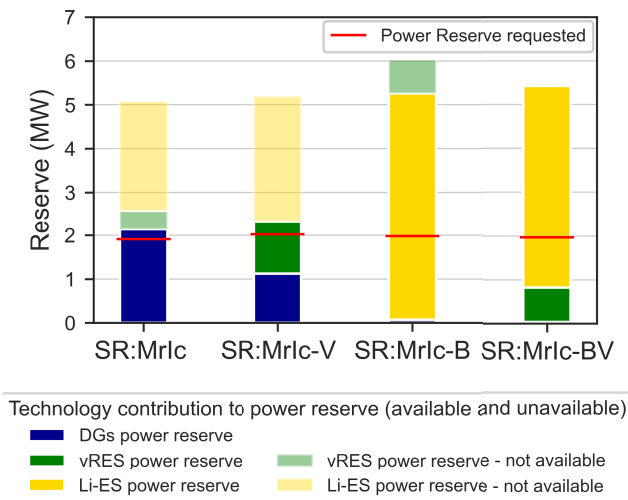

FIGURE 6. Power reserve contributions from different technologies in four different scenarios, with the total reserve displayed as a stacked bar. The blue segments represent the power reserve supplied by DGs, while the green and gold segments correspond to the reserve from vRES and Li-ES, respectively. The transparent segments show the power reserve from vRES and Li-ES, unavailable due to the respective scenario model settings (reported in Table 2).

double in BESS investment, which suggests that the provision of the power reserve of BESS is highly influenced by the reserve management dispatch more than by the size of the BESS itself. This outcome highlights the need to integrate the BESS power reserve provision model into the long-term dispatch analysis, together with accurate cost modelling of DGs and power reserve requirements.

The line graph in Figure 7 compares the cumulative available power reserve in different scenarios, including the baseline scenario (BS:MrIc) and the four scenarios with power reserve requirements (SR:MrIc, SR:MrIc-V, SR:MrIc-B, and SR:MrIc-BV). The graph illustrates that in the BS case, the reserve requirement is not guaranteed, as the curve falls (largely) into the negative area. On the other hand, BESS highly increases the total number of hours of contribution to reserve throughout the year as the trendline is well beyond

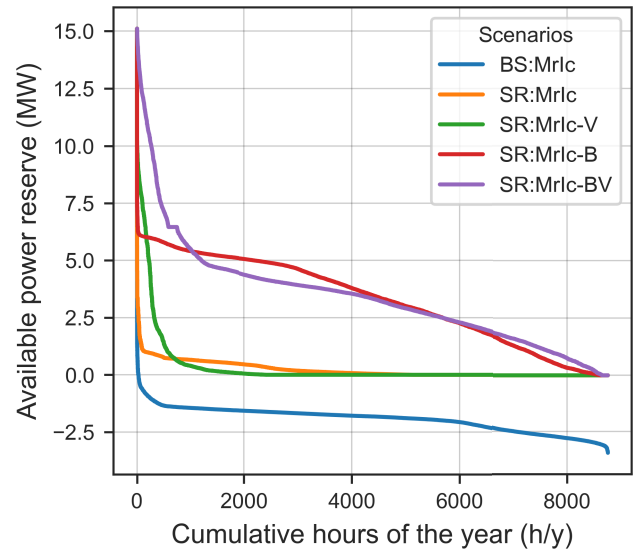

FIGURE 7. Representation of the total available power reserve as cumulative hours of the year. Comparison among different scenarios. Comparison of total available power reserve across scenarios as a function of cumulative hours of the year. The scenarios compared are: BS:MrIc (Baseline), SR:MrIc, SR:MrIc-V, SR:MrIc-B, and SR:MrIc-BV.

the minimum required reserve. On the other hand, in the DG-only case (SR:MrIc), the minimum reserve provision is guaranteed.

The specific temporal distribution of the reserve surplus is highlighted in Figure 8 for all hours of the year. The power reserve surplus is the amount of reserve in excess of the demand for each hour of the year. The colour map is presented for the two most relevant scenarios: SR:MrIc and SR:MrIc-B. The graphs demonstrate the significant contribution of BESS to the provision of power reserve, with surplus values exceeding 200% for most of the year. The most critical hours where reserve reaches the bare minimum are the early morning hours, where BESS tend to be at low SoC due to the night discharge phase.

These results highlight the effectiveness of BESS in ensuring a robust power supply throughout the year, contributing to the reliability and stability of the power system.

D. IMPACT OF POWER RESERVE MANAGEMENT ON FUEL GENERATORS BEHAVIOUR

In this section, the behavior of DGs is analyzed using the results obtained from the simulation conducted over the full year with power reserve requirements set to Rq1 (as reported in Table 7). The scatter plot in Figure 9 compares the production costs of the DGs (in €/MWh) with the total working hours of the generators (in hours) and the average number of activated generators per hour (size of scatter). The data points correspond to the four different scenarios with the power reserve included in the model. The scatter plot shows how the integration of the power reserve significantly reduces the working hours of the DGs and the average number of active generators per hour. These results are consistent with

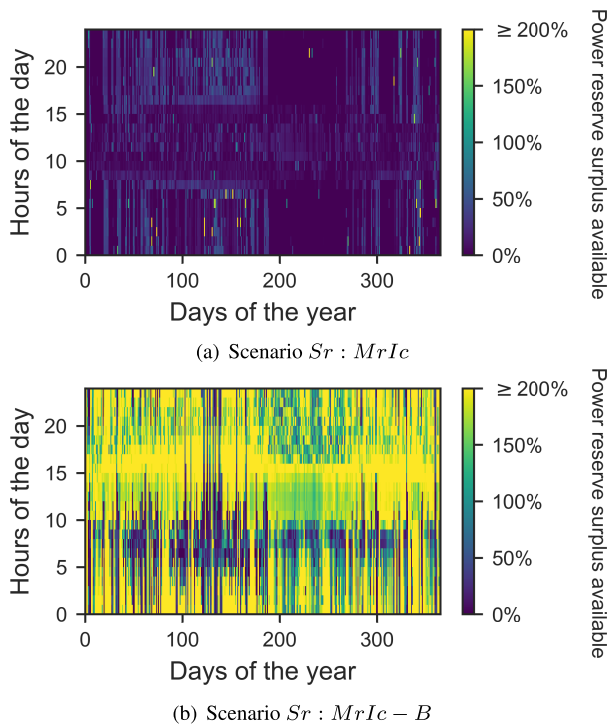

FIGURE 8. Percentage power reserve surplus with respect the required reserve per each hour of the simulated year.

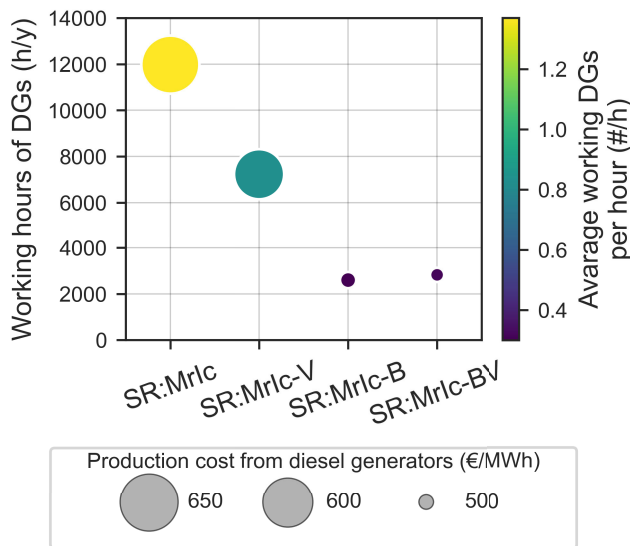

FIGURE 9. Comparison of diesel generators’ production cost, total working hours, and mean number of activated generators.

the lower fuel consumption discussed earlier. Furthermore, the graph shows that the integration of BESS also leads to a reduction in the specific production costs of the DGs (up to -23%). This means that not only the DGs are in operation for fewer hours, but they also deliver a higher power output, thus working more efficiently when activated.

The violin plots in Figure 10 illustrate the behaviour of the eight DGs under the four scenarios with implemented

reserve requirements. The y-axis represents the output power in megawatts (MW), and the notch width corresponds to the working hours at which the generators supply that specific output power. The plots show that in the first two scenarios, where the DGs are used to provide power reserve, they operate with a percentage output power in the range 40-70%. This limitation is due to the need to reserve a portion of their capacity for power reserve purposes. In contrast, in the last two scenarios, where the DGs are not used for providing power reserve (as discussed in Section V-C), they can operate at maximum power output. Although power reserve from the DGs is possible in the last two scenarios, the economically optimal solutions do not include their contribution to power reserve supply. In summary, by using BESS for the power reserve, the auxiliary reserve is achieved at a lower cost, also thanks to DGs working less and better.

E. SENSITIVITY ANALYSIS TO THE POWER RESERVE REQUIREMENTS

Lastly, a sensitivity analysis is carried out to examine the impact of the power reserve requirements into the results. The power reserve requirements are thus gradually increased based on the parameter settings given in Table 4 (Rq1, Rq2, Rq3, Rq4). In this analysis, the four scenarios are simulated with the inclusion of the power reserve model for four representative weeks. The aim is to investigate the sensitivity of the system performance in response to different power reserve demands. The simulation results for these scenarios are reported in Section C.

The bar chart in Figure 11 illustrates the percentage increase of the annual system costs for the different scenarios compared to the base-case scenario SR:MrIc- BV with Rq1; the power reserve requirements range from Rq1 to Rq4, which means an increase of up to $+265\%$.

The annualised costs of the first two scenarios follow this increasing trend, with an increase in costs of about 80% compared to the reference scenario. In contrast, the cost increase is limited to 5% in the last two scenarios, even at the most demanding reserve requirement settings (Rq4). In conclusion, the graph in Figure 11 illustrates how integrating BESS into the power supply not only increases the security and reliability of the system, but also increases its adaptability and resilience: by effectively using BESS, the system can meet higher power reserve requirements without incurring significant cost escalations.

VI. CONCLUSION

The proposed study successfully enables the optimal planning and dispatch for microgrids, including an accurate cost model for fuel-fired generators and power reserve requirements. Furthermore, practical guidelines are provided to facilitate the optimal design and development of off-grid systems, ensuring their effectiveness and efficiency. A sensitivity on the modelling formulation has been performed, proposing different scenarios and their impact into the practical system operation, to thoroughly analyze the

TABLE 8. DG models installed at the Pantelleria power plant.

| DG id | Engine model | Alternator model | Nominal power (kWe) |
|-------|------------------------------------|---|---------------------|
| DG 1 | MAN G8V 30/45ATL | SIEMENS - 500 g/1' - 400 V 1DK 4815-5 DE 06-Z | 1188 |
| DG 2 | WARTSILA 12V32 | ABB - 750 g/1' - 11000 V AMG0900LR08 | 4864 |
| DG 3 | WARTSILA NOHAB 16V25 | LEROY SOMER - 750 g/1' - 5000 V LSA 56 L8 | 2928 |
| DG 4 | WARTSILA 16V25 | LEROY SOMER - 750 g/1' - 5000 V LSA 56 UL/8P | 2818 |
| DG 5 | WARTSILA 6L32 | ABB - 750 g/1' - 6000 V AMG0710LP08 DSE | 2889 |
| DG 6 | NORDBERG FSG 1316 HSC | WESTINGHOUSE 428 g/1' - 3800V ES 8P | 2555 |
| DG 7 | DEUTZ POWER SYSTEM TCD 2020 V16 G3 | LEROY SOMER - 1500 g/1' - 8400 V LSA53UL85 | 1698 |
| DG 8 | WARTSILA 12V32 | ABB - 750 g/1' - 11000 V AMG0900LR08 DSE | 5327 |

TABLE 9. DG models installed at the Pantelleria power plant and their corresponding parameters used for cost characterization.

| Engine | Nominal power (kWe) | Specific consumption curve ($\frac{kg}{kWh}$) | | | | Marginal consumption ($\frac{g}{kWh}$) | Idling consumption ($\frac{g}{h}$) | Normalized idling consumption ($\frac{g}{kWh}$) |
|--------------------|---------------------|---|-----------------|-----------------|------------------|--|--------------------------------------|---|
| | | 50% $P_{nom,i}$ | 75% $P_{nom,i}$ | 85% $P_{nom,i}$ | 100% $P_{nom,i}$ | | | |
| WARTSILA 6L32 | 3300 kWe | 314.4 | 518.0 | 457.0 | 612.7 | 177.6 | $30.7 \cdot 10^3$ | 4.4 |
| WARTSILA 12V32 | 6960 kWe | 653.7 | 950.9 | 1,076.7 | 1,273.7 | 178.6 | $14.5 \cdot 10^3$ | 4.4 |
| WARTSILA 16V32 | 9280 kWe | 869.2 | 1,266.7 | 1,436.9 | 1,701.3 | 178.8 | $32.5 \cdot 10^3$ | 3.5 |
| WARTSILA NOHAB F30 | 2620 kWe | 248.9 | 369.4 | n.a. | 497.8 | 187.0 | $7.9 \cdot 10^3$ | 3.0 |

TABLE 10. Mean value of power reserve provided by the different techs and focus on behaviour of the DGs for the 5 scenarios simulated throughout the full year with hourly time steps, with reserve requirements set to Rq1.

| Scenario (MW) | Mean power reserve provided by | | | | | Mean output power of DGs (when activated) (MW) | | | | | | | |
|---------------|--------------------------------|-----------|-----------|--------------------|----------|--|----------------|----------------|----------------|----------------|----------------|----------------|----------------|
| | DGs (MW) | BESS (MW) | vRES (MW) | DGs+BESS+vRES (MW) | Rq1 (MW) | DG 1 (1118 kW) | DG 2 (5040 kW) | DG 3 (2928 kW) | DG 4 (2920 kW) | DG 5 (3089 kW) | DG 6 (2582 kW) | DG 7 (1760 kW) | DG 8 (5520 kW) |
| BS:MrIc | 0.04 | 3.68 | 0.82 | 4.55 | 1.98 | 1.04 | 4.89 | 2.78 | 2.84 | 2.85 | 2.39 | 1.60 | 5.04 |
| SR:MrIc | 2.14 | 2.49 | 0.44 | 5.07 | 1.91 | 0.25 | 3.46 | 1.57 | 1.05 | 1.28 | 0.57 | 0.39 | 3.84 |
| SR:MrIc-V | 1.12 | 2.85 | 1.22 | 5.19 | 2.02 | 0.43 | 3.87 | 1.52 | 1.55 | 1.32 | 0.81 | 0.41 | 3.76 |
| SR:MrIc-B | 0.07 | 5.19 | 0.78 | 6.04 | 1.98 | 0.94 | 4.87 | 2.81 | 2.78 | 2.99 | 2.26 | 1.47 | 5.45 |
| SR:MrIc-BV | 0.04 | 4.61 | 0.75 | 5.41 | 1.97 | 0.96 | 5.01 | 2.85 | 2.87 | 3.04 | 2.45 | 1.54 | 5.52 |

TABLE 11. Simulation results of the 4 scenarios conducted over four representative weeks with reserve requests set to Rq2, Rq3, Rq4.

| Scenario | Time horizon | Reserve requir. | End Toll. | Comp. time (s) | f_{obj} (M€) | Optimal size of components | | | | Share RES (%) | Hours with reserve satisfied by: | | Diesel generators | | | | |
|------------|--------------|-----------------|-----------|----------------|----------------|----------------------------|-----------|------------|-----------------|---------------|----------------------------------|----------|-------------------|---------------------|--------------------|----------------|-----------|
| | | | | | | PV (MW) | FOWT (MW) | BESS (MWh) | BESS conv. (MW) | | DGs | DGs+BESS | Work. hours (h) | Avg. DGs "on" (#/h) | Max DGs "on" (#/h) | Load fact. (%) | Fuel (kl) |
| SR:MrIc | 4W | Rq2 | 0.86% | 826 | 9.98 | 15.00 | 3.19 | 30.53 | 6.63 | 75.4% | 672 | 672 | 954 | 1.42 | 3 | 23% | 167 |
| SR:MrIc-V | 4W | Rq2 | 0.98% | 212 | 8.91 | 15.00 | 5.47 | 26.86 | 5.26 | 80.9% | 244 | 586 | 560 | 0.83 | 3 | 30% | 128 |
| SR:MrIc-B | 4W | Rq2 | 0.80% | 34 | 7.76 | 15.00 | 4.05 | 33.32 | 6.66 | 81.3% | 4 | 672 | 199 | 0.30 | 3 | 88% | 121 |
| SR:MrIc-BV | 4W | Rq2 | 0.74% | 21 | 7.74 | 15.00 | 4.09 | 33.11 | 6.66 | 81.4% | 0 | 661 | 217 | 0.32 | 3 | 93% | 120 |
| SR:MrIc | 4W | Rq3 | 0.89% | 2471 | 10.27 | 15.00 | 3.15 | 31.81 | 6.63 | 75.2% | 672 | 672 | 1074 | 1.60 | 3 | 21% | 169 |
| SR:MrIc-V | 4W | Rq3 | 0.93% | 137 | 9.18 | 15.00 | 5.62 | 26.53 | 5.33 | 80.7% | 228 | 562 | 624 | 0.93 | 4 | 31% | 130 |
| SR:MrIc-B | 4W | Rq3 | 0.99% | 30 | 7.79 | 15.00 | 3.97 | 32.26 | 6.85 | 80.9% | 3 | 672 | 210 | 0.31 | 3 | 86% | 124 |
| SR:MrIc-BV | 4W | Rq3 | 0.86% | 22 | 7.77 | 15.00 | 4.03 | 33.35 | 6.98 | 81.3% | 3 | 664 | 192 | 0.29 | 3 | 90% | 121 |
| SR:MrIc | 4W | Rq4 | 1.72% | 9470 | 14.22 | 15.00 | 2.51 | 30.06 | 5.73 | 66.8% | 672 | 672 | 1850 | 2.75 | 5 | 16% | 237 |
| SR:MrIc-V | 4W | Rq4 | 0.80% | 75 | 12.33 | 15.00 | 9.99 | 23.72 | 5.30 | 79.6% | 173 | 334 | 1101 | 1.64 | 5 | 18% | 144 |
| SR:MrIc-B | 4W | Rq4 | 0.95% | 30 | 8.01 | 15.00 | 4.12 | 38.85 | 11.98 | 81.6% | 0 | 672 | 191 | 0.28 | 3 | 85% | 119 |
| SR:MrIc-BV | 4W | Rq4 | 0.81% | 23 | 7.99 | 15.00 | 3.99 | 37.65 | 12.02 | 81.2% | 0 | 658 | 200 | 0.30 | 3 | 90% | 121 |

impact of each asset and their mutual influence over full year simulations. Through the study, several important findings emerge:

- 1) accurate modelling of FFG operations is critical to realistically assess the benefits they offer, not to incur in underestimating costs by 30%;
- 2) system planning must take into account the need for power reserve requirements to avoid underestimating system demand, total cost by 25%, and fuel consumption by 50%;
- 3) using only FFGs and vRES technologies for power reserve leads to about 15% higher costs with respect to the case without reserve requirements implemented. However, if storage can provide reserve supply, the impact of power reserve demand on costs becomes negligible;

- 4) enabling storage to supply reserve significantly reduces overall system costs (up to -20%) and lowers fuel consumption (-35%);
- 5) using storage capacity as a reserve significantly increases available capacity and exceeds requirements by more than 200% for most hours of the year, with minimal cost escalation;
- 6) storage not only provides cost-effective reserve capacity, but also optimises the performance of FFGs:
 - reduced operating hours of DGs (< 0.5 working FFGs per hour) enable a reduction in the required generator fleet, allowing policy makers to consider decommissioning or not replacing FFGs;
 - FFGs operate at higher efficiency (when activated), with lower emissions and specific production costs (up to -23%). The efficient provision of power

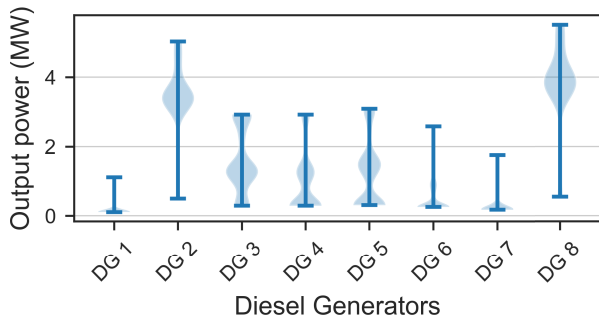

(a) Scenario $Sr : MrIc$

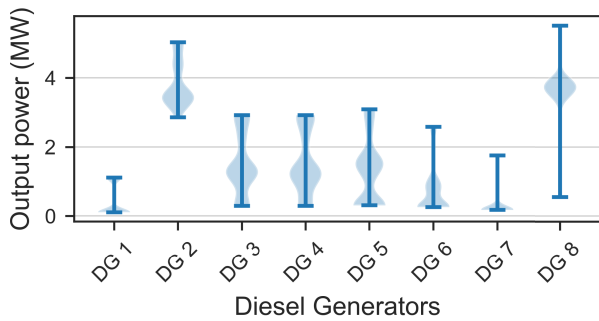

(b) Scenario $Sr : MrIc - V$

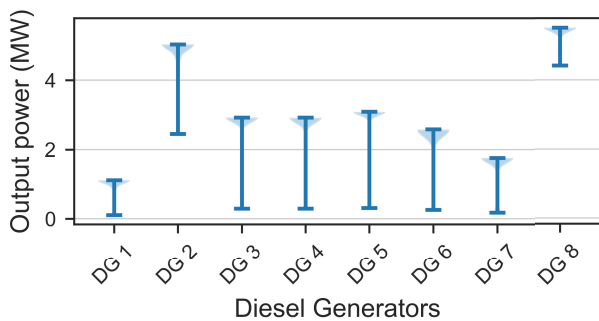

(c) Scenario $Sr : MrIc - B$

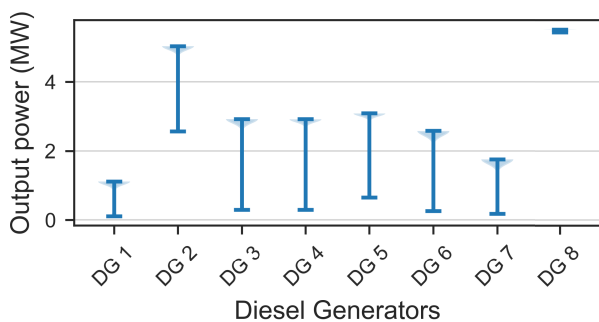

(d) Scenario $Sr : MrIc - BV$

FIGURE 10. Violin plot showing the distribution of output power for eight DGs under four different scenarios.

reserve through BESS eliminates the need for excess buffer capacity associated with FFGs;

- 7) vRES only contribute to a limited extent to the provision of reserve, which only has a significant impact when

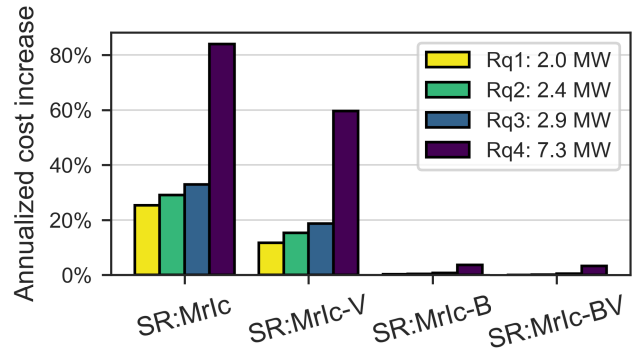

FIGURE 11. Impact of different power reserve requirements (mean annual value of Rq) on the annualized system cost, expressed as a percentage increase relative to the reference scenario $SR:MrIc-BV$ with $Rq1$. Simulation conducted for four representative weeks.

storage is not included for power reserve supply (−10% annualized system cost and −39% fuel consumption);

- 8) the comprehensive model shows that the optimal sizing of BESS is about 15% higher when storage is considered for the provision of reserve.

The results of this study provide guidelines for the modelling and planning of reserve in offgrid systems and highlights the central role of storage technologies in ensuring a fast, economically viable, resilient and efficient energy transition for off-grid system. Future work can investigate simplified techniques to account for different reserve types (i.e. primary, secondary, and tertiary reserve), and the impact of modular capacity expansion. Although the achieved results remain valid, future studies will enable a more accurate quantification of the impact of power reserve requirements.

APPENDIX A

DIESEL GENERATORS PARAMETERS

The information shared by the Pantelleria Island’s DSO regarding the size and models of the installed DGs are listed in Table 8.

The parameters of the DGs associated with the ones actually installed are listed in the Table 9.

APPENDIX B

ANALYSIS OF RESERVE AND DG PERFORMANCE IN FULL-YEAR SIMULATIONS: NUMERICAL INSIGHTS

Table 10 displays the average power reserve provided by different technologies for each scenario, along with the mean power output percentage of the activated eight DGs. These value refers to the simulation reported in 7 and they are extensively discussed in Section V-B and visually represented in Figures 6 and 10, respectively.

APPENDIX C

SENSITIVITY ANALYSIS OF POWER RESERVE REQUIREMENTS: SIMULATION RESULTS

The simulation results of the sensitivity analysis on power reserve requirements are presented in Table 11. As explained

in Section V-E, the scenarios with various reserve options are simulated with four different reserve request settings (see Table 4). All these simulations were conducted over four representative weeks.

REFERENCES

- [1] *Renewables 2022: Analysis and Forecast to 2027*, Int. Energy Agency (OECD), Paris, France, 2022.
- [2] M. Martínez-Barbeito, D. Gomila, and P. Colet, "Dynamical model for power grid frequency fluctuations: Application to islands with high penetration of wind generation," *IEEE Trans. Sustain. Energy*, vol. 14, no. 3, pp. 1436–1445, Jul. 2023.
- [3] X. Deng and T. Lv, "Power system planning with increasing variable renewable energy: A review of optimization models," *J. Cleaner Prod.*, vol. 246, Feb. 2020, Art. no. 118962.
- [4] D. Haase and A. Maier, "Research for REGI committee—Islands of the European Union: State of play and future challenges," Policy Dept. Struct. Cohesion Policies, European Parliament, Tech. Rep. PE 652.239 and 'REGI/INT/NT/2021-001, Mar. 2021.
- [5] *Transforming Small-Island Power Systems: Technical Planning Studies for the Integration of Variable Renewables*, Int. Renew. Energy Agency, Abu Dhabi, United Arab Emirates, Dec. 2018.
- [6] N. Helistö, J. Kiviluoma, H. Holttinen, J. D. Lara, and B. Hodge, "Including operational aspects in the planning of power systems with large amounts of variable generation: A review of modeling approaches," *WIREs Energy Environ.*, vol. 8, no. 5, p. e341, Sep. 2019.
- [7] C. S. Lai, G. Locatelli, A. Pimm, X. Wu, and L. L. Lai, "A review on long-term electrical power system modeling with energy storage," *J. Cleaner Prod.*, vol. 280, Jan. 2021, Art. no. 124298.
- [8] A. Fattahi, M. S. Diéguez, J. Sijm, G. M. España, and A. Faaij, "Measuring accuracy and computational capacity trade-offs in an hourly integrated energy system model," *Adv. Appl. Energy*, vol. 1, Feb. 2021, Art. no. 100009.
- [9] G. Diaz, A. Inzunza, and R. Moreno, "The importance of time resolution, operational flexibility and risk aversion in quantifying the value of energy storage in long-term energy planning studies," *Renew. Sustain. Energy Rev.*, vol. 112, pp. 797–812, Sep. 2019.
- [10] K. Poncet, E. Delarue, and W. D'haeseleer, "Unit commitment constraints in long-term planning models: Relevance, pitfalls and the role of assumptions on flexibility," *Appl. Energy*, vol. 258, Jan. 2020, Art. no. 113843.
- [11] P. Marocco, R. Novo, A. Lanzini, G. Mattiazzo, and M. Santarelli, "Towards 100% renewable energy systems: The role of hydrogen and batteries," *J. Energy Storage*, vol. 57, Jan. 2023, Art. no. 106306.
- [12] R. Novo, P. Marocco, G. Giorgi, A. Lanzini, M. Santarelli, and G. Mattiazzo, "Planning the decarbonisation of energy systems: The importance of applying time series clustering to long-term models," *Energy Convers. Manag.*, vol. 15, Aug. 2022, Art. no. 100274.
- [13] M. F. Ishraque, S. A. Shezan, M. M. Ali, and M. M. Rashid, "Optimization of load dispatch strategies for an islanded microgrid connected with renewable energy sources," *Appl. Energy*, vol. 292, Jun. 2021, Art. no. 116879.
- [14] E. Dudkina, D. Fioriti, E. Crisostomi, and D. Poli, "On the impact of different electricity markets on the operation of a network of microgrids in remote areas," *Electr. Power Syst. Res.*, vol. 212, Nov. 2022, Art. no. 108243.
- [15] Y.-K. Wu, S.-R. Huang, W.-S. Tan, and C.-P. Chiu, "Impact of generation flexibility on the operating cost under a high penetration of renewable power integration," in *Proc. IEEE Ind. Appl. Soc. Annu. Meeting*, Sep. 2019, pp. 1–11.
- [16] Z. Tang, Y. Liu, L. Wu, J. Liu, and H. Gao, "Reserve model of energy storage in day-ahead joint energy and reserve markets: A stochastic UC solution," *IEEE Trans. Smart Grid*, vol. 12, no. 1, pp. 372–382, Jan. 2021.
- [17] Z. Li, P. Yang, Z. Zhao, and L. L. Lai, "Retrofit planning and flexible operation of coal-fired units using stochastic dual dynamic integer programming," *IEEE Trans. Power Syst.*, early access, Feb. 7, 2023, doi: 10.1109/TPWRS.2023.3243093.
- [18] M. Navia, R. Orellana, S. Zaráte, M. Villazón, S. Balderrama, and S. Quoilin, "Energy transition planning with high penetration of variable renewable energy in developing countries: The case of the Bolivian interconnected power system," *Energies*, vol. 15, no. 3, p. 968, Jan. 2022.
- [19] X. Han, X. Chen, M. B. McElroy, S. Liao, C. P. Nielsen, and J. Wen, "Modeling formulation and validation for accelerated simulation and flexibility assessment on large scale power systems under higher renewable penetrations," *Appl. Energy*, vol. 237, pp. 145–154, Mar. 2019.
- [20] S. S. Oskouee, S. Kamali, and T. Amraee, "Primary frequency support in unit commitment using a multi-area frequency model with flywheel energy storage," *IEEE Trans. Power Syst.*, vol. 36, no. 6, pp. 5105–5119, Nov. 2021.
- [21] L. Tziiovani, M. Savva, M. Asprou, P. Kolios, E. Kyriakides, R. Tapakis, M. Michael, and C. Hadjilaou, "Assessing the operational flexibility in power systems with energy storage integration," in *Flexitranstore*. Cham, Switzerland: Springer, 2020.
- [22] A. Flores-Quiroz and K. Strunz, "A distributed computing framework for multi-stage stochastic planning of renewable power systems with energy storage as flexibility option," *Appl. Energy*, vol. 291, Jun. 2021, Art. no. 116736.
- [23] N. Helistö, J. Kiviluoma, G. Morales-España, and C. O'Dwyer, "Impact of operational details and temporal representations on investment planning in energy systems dominated by wind and solar," *Appl. Energy*, vol. 290, May 2021, Art. no. 116712.
- [24] A. Vargiu, R. Novo, C. Moscoloni, E. Giglio, G. Giorgi, and G. Mattiazzo, "An energy cost assessment of future energy scenarios: A case study on San Pietro Island," *Energies*, vol. 15, no. 13, p. 4535, Jun. 2022.
- [25] T. Brijs, A. van Stiphout, S. Siddiqui, and R. Belmans, "Evaluating the role of electricity storage by considering short-term operation in long-term planning," *Sustain. Energy, Grids Netw.*, vol. 10, pp. 104–117, Jun. 2017.
- [26] X. Wu, W. Zhao, H. Li, B. Liu, Z. Zhang, and X. Wang, "Multi-stage stochastic programming based offering strategy for hydrogen fueling station in joint energy, reserve markets," *Renew. Energy*, vol. 180, pp. 605–615, Dec. 2021.
- [27] M. Petrelli, D. Fioriti, A. Berizzi, and D. Poli, "Multi-year planning of a rural microgrid considering storage degradation," *IEEE Trans. Power Syst.*, vol. 36, no. 2, pp. 1459–1469, Mar. 2021.
- [28] H.-K. Ringkjøb, P. M. Haugan, and I. M. Solbrenke, "A review of modelling tools for energy and electricity systems with large shares of variable renewables," *Renew. Sustain. Energy Rev.*, vol. 96, pp. 440–459, Nov. 2018.
- [29] Y. Jiang, L. Kang, and Y. Liu, "Optimal configuration of battery energy storage system with multiple types of batteries based on supply-demand characteristics," *Energy*, vol. 206, Sep. 2020, Art. no. 118093.
- [30] N. Zhang, H. Jiang, E. Du, Z. Zhuo, P. Wang, Z. Wang, and Y. Zhang, "An efficient power system planning model considering year-round hourly operation simulation," *IEEE Trans. Power Syst.*, vol. 37, no. 6, pp. 4925–4935, Nov. 2022.
- [31] N. Zhang, Q. Sun, L. Yang, and Y. Li, "Event-triggered distributed hybrid control scheme for the integrated energy system," *IEEE Trans. Ind. Informat.*, vol. 18, no. 2, pp. 835–846, Feb. 2022.
- [32] E. Giglio and D. Fioriti, "Add stand-by cost," Tech. Rep., 2023. Accessed: Aug. 25, 2023. [Online]. Available: <https://github.com/PyPSA/PyPSA/pull/659>
- [33] T. Brown, J. Hörsch, and D. Schlachtberger, "PyPSA: Python for power system analysis," *J. Open Res. Softw.*, vol. 6, no. 1, p. 4, Jan. 2018.
- [34] C. Moscoloni, F. Zarra, R. Novo, E. Giglio, A. Vargiu, G. Mutani, G. Bracco, and G. Mattiazzo, "Wind turbines and rooftop photovoltaic technical potential assessment: Application to sicilian minor islands," *Energies*, vol. 15, no. 15, p. 5548, Jul. 2022.
- [35] Y. Liu, L. Guo, R. Hou, C. Wang, and X. Wang, "A hybrid stochastic/robust-based multi-period investment planning model for island microgrid," *Int. J. Electr. Power Energy Syst.*, vol. 130, Sep. 2021, Art. no. 106998.
- [36] *Renewable Power Generation Costs in 2021*, Int. Renew. Energy Agency, Masdar City, United Arab Emirates, 2022.
- [37] *2022 Annual Technology Baseline*, Nat. Renew. Energy Lab. (NREL), Golden, CO, USA, 2022.
- [38] M. Shields, P. Duffy, W. Musial, M. Laurienti, D. Heimiller, R. Spencer, and M. Optis, "The costs and feasibility of floating offshore wind energy in the O'ahu region," Nat. Renew. Energy Lab. (NREL), Golden, CO, USA, Tech. Rep. NREL/TP-5000-80808, Oct. 2021.
- [39] W. Cole, A. Frazier, and C. Augustine, "Cost projections for utility-scale battery storage: 2021 update," Nat. Renew. Energy Lab. (NREL), Golden, CO, USA, Tech. Rep. NREL/TP-6A20-79236, Jun. 2021.
- [40] R. Novo, F. D. Minuto, G. Bracco, G. Mattiazzo, R. Borchellini, and A. Lanzini, "Supporting decarbonization strategies of local energy systems by de-risking investments in renewables: A case study on Pantelleria Island," *Energies*, vol. 15, no. 3, p. 1103, Feb. 2022.

- [41] H. Hersbach, B. Bell, P. Berrisford, S. Hirahara, and J. Thépaut, "The ERA5 global reanalysis," *Quart. J. Roy. Meteorolog. Soc.*, vol. 146, no. 730, pp. 1999–2049, 2020.
- [42] F. Ahmed, D. A. Kez, S. McLoone, R. J. Best, C. Cameron, and A. Foley, "Dynamic grid stability in low carbon power systems with minimum inertia," *Renew. Energy*, vol. 210, pp. 486–506, Jul. 2023.
- [43] R. Yudhistira, D. Khatiwada, and F. Sanchez, "A comparative life cycle assessment of lithium-ion and lead-acid batteries for grid energy storage," *J. Cleaner Prod.*, vol. 358, Jul. 2022, Art. no. 131999.
- [44] F. B. Jasper, J. Späthe, M. Baumann, J. F. Peters, J. Ruhland, and M. Weil, "Life cycle assessment (LCA) of a battery home storage system based on primary data," *J. Cleaner Prod.*, vol. 366, Sep. 2022, Art. no. 132899.
- [45] *User's Manual for CPLEX*, document Version 20.1.1, CPLEX and IBM ILOG, Int. Bus. Mach. Corp., Armonk, NY, USA, Mar. 2021.
- [46] Y.-K. Wu, W.-S. Tan, Y.-S. Chiang, and C.-L. Huang, "Planning of flexible generators and energy storages under high penetration of renewable power in Taiwan power system," *Energies*, vol. 15, no. 14, p. 5224, Jul. 2022.
- [47] D. Curto, S. Favuzza, V. Franzitta, A. Guercio, M. A. N. Navia, E. Telaretti, and G. Zizzo, "Grid stability improvement using synthetic inertia by battery energy storage systems in small islands," *Energy*, vol. 254, Sep. 2022, Art. no. 124456.
- [48] F. Ramos, A. Pinheiro, R. Nascimento, W. de Araujo Silva Jr., M. A. Mohamed, A. Annuk, and M. H. N. Marinho, "Development of operation strategy for battery energy storage system into hybrid AC microgrids," *Sustainability*, vol. 14, no. 21, p. 13765, Oct. 2022.
- [49] *Wärtsilä 32 Product Manual*, Wärtsilä Oyj Abp, Helsinki, Finland, Sep. 2016.
- [50] *Wärtsilä Nohab F30*, Wärtsilä Diesel AB, Helsinki, Finland, 1980.
- [51] *Open Data-Analisi e Statistiche Energetiche e Minerarie*, Ministero Dell'ambiente e Della Sicurezza Energetica, Rome, Italy, 2023.
- [52] A. Q. Jakhani, A. R. H. Rigit, A.-K. Othman, S. R. Samo, and S. A. Kamboh, "Estimation of carbon footprints from diesel generator emissions," in *Proc. Int. Conf. Green Ubiquitous Technol.*, Jul. 2012, pp. 78–81.
- [53] M. Mohseni, S. F. Moosavian, and A. Hajinezhad, "Feasibility evaluation of an off-grid solar-biomass system for remote area electrification considering various economic factors," *Energy Sci. Eng.*, vol. 10, no. 8, pp. 3091–3107, Aug. 2022.
- [54] N. Green, M. Mueller-Stoffels, and E. Whitney, "An Alaska case study: Diesel generator technologies," *J. Renew. Sustain. Energy*, vol. 9, no. 6, Nov. 2017, Art. no. 061701.



energy planning, and spatial energy planning.

RICCARDO NOVO was born in 1993. He received the M.S. degree in energy and nuclear engineering and the Ph.D. degree in mechanical engineering from Politecnico di Torino (PoliTo), in 2018 and 2022, respectively. In PoliTo, he especially works on the models and scenarios for the energy transition of islands, with a focus on long-term energy system models and future technologies. His research interests include energy communities, wind energy, energy system analysis, optimal



renewable energy applications, with a particular focus on the development of wave energy converters, floating offshore wind plants, and decarbonization strategies for local energy communities.

GIULIANA MATTIAZZO received the M.Sc. degree in aerospace engineering and the Ph.D. degree in applied mechanics from Politecnico di Torino, Turin, Italy, in 1991 and 1994, respectively. She is currently a Full Professor with the Department of Mechanical and Aerospace Engineering, Politecnico di Torino, where she is also the Vice Rector for Technology Transfer and the Coordinator of the Marine Offshore Renewable Energy Laboratory. Her research interests include



2021, he has been highly involved in the PyPSA meets Earth initiative promoting open-source energy planning with Earth scope. He is involved as a Researcher in the EU-financed LEAP-RE Project on Long-Term Joint EU-AU Research and Innovation Partnership on Renewable Energy. In 2018, he was a Visiting Scholar with the Massachusetts Institute of Technology.

DAVIDE FIORITI (Member, IEEE) received the M.Sc. and Ph.D. degrees in electrical engineering from the University of Pisa. He is an Assistant Professor with the University of Pisa and teaches "Energy Economics and Technologies." His interests fall into mathematical optimization applied to small- and large-scale energy systems, including microgrids, rural electrification, and least-cost decarbonization strategies applied to country and continental energy systems. Since



ENRICO GIGLIO received the B.S. and M.S. degrees in mechanical engineering from Politecnico di Torino, in 2019 and 2021, respectively, where he is currently pursuing the Ph.D. degree in mechanical engineering.

His research interests include short-term energy scenario models, with a focus on islanded systems with high-RES penetration.

Open Access funding provided by 'Politecnico di Torino' within the CRUI CARE Agreement