

Improved Performance in a Supercapacitor-Based Energy Storage Control System with Bidirectional DC-DC Converter for Elevator Motor Drives

Nikolaos Jabbour*, Christos Mademlis* and Iordanis Kioskeridis †

*Faculty of Electrical and Computer Engineering, Aristotle University of Thessaloniki, GR-54 124, Greece, Email: mademlis@eng.auth.gr

†Department of Electronics Engineering, Alexander Technological Educational Institute of Thessaloniki, GR-57 400, Greece, Email: ikiosker@el.teithe.gr

Keywords: Elevator motor drive, energy storage, control system, braking energy, supercapacitor.

Abstract

A supercapacitor-based energy storage control scheme for elevator motor drives that exhibits improved performance and maximum exploitation of the storage device is proposed in this paper. The suggested energy storage system is connected to the dc-link of an elevator motor drive through a bidirectional *dc-dc* converter and the braking energy is stored at the supercapacitor bank. Aim of the control scheme is to ensure power supply to the elevator motor as possible from the temporary stored energy of the supercapacitors, in order to minimize the power consumption from the grid. Also, since the capacitance of the supercapacitor and consequently the energy storage capability reduces with increasing frequency, the proposed control scheme aims to provide smooth charging and discharging performance. This is attained by optimally controlling the *dc-dc* power converter through a new control technique that takes into account any variations of the *ac* supply voltage to the elevator motor drive and also on-line adjusting the *dc-link* voltage Proportional-Integral (PI) controller parameters according to the elevator operating conditions. Several simulation results are presented to demonstrate the resulting improvements of the suggested control scheme

1 Introduction

The electric machine of a traction elevator either consumes or produces electric energy depending on the moving direction of the cabin and its weight in relation to counterweight. Specifically, maximum energy consumption is attained when the elevator cabin is moving up with full load or moving down empty. Whereas, maximum energy is produced by the elevator motor when the cabin is moving down with full load or moving up empty. In conventional elevators, the produced electrical energy, which is referred as braking energy, is dissipated to a braking resistor. However, this energy can be temporarily accumulated in an energy storage device and then it could be recovered when the elevator turns to motoring operation. Therefore, the energy that is provided from the grid is reduced and thus, the total efficiency of the elevator motion system is improved.

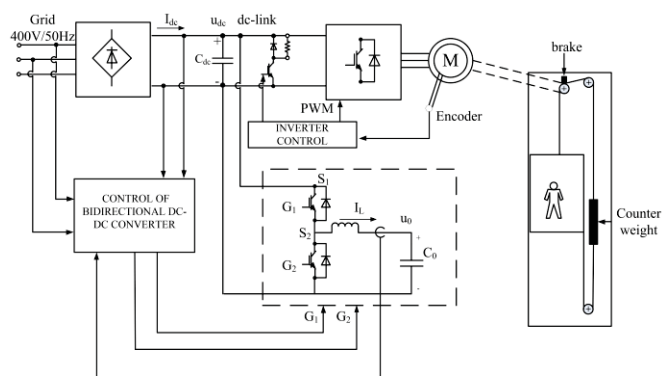

Fig. 1: Structure of the proposed elevator system. The braking energy is stored to a supercapacitor bank that is controlled through a bidirectional *dc-dc* converter.

Various research works have been published in the technical literature aiming to save the produced electric energy during the braking (generating) operation of an elevator system, by using batteries or supercapacitors as temporarily storage device. Specifically, S. Tominaga et al. [1] proposed a nickel metal-hydride (Ni-MH) batteries energy storage system for elevator applications. A. Rufer and P. Barrade [2] presented a supercapacitor-based energy storage system with soft commutated interface. As temporarily energy storage system, supercapacitors were proposed for several other moving applications, i.e. electric vehicles [3], wind systems [4] etc. Also, the fuzzy-logic based control system proposed by Zheng Li and Yi Ruan [5] can improve the efficiency of an elevator system; however, the influence of grid voltage variation on the performance of the supercapacitor energy saving system has not been taken into account.

Fig. 1 illustrates the proposed elevator system with a supercapacitor bank for the energy storage. Specifically, it consists of the elevator cabin, the electric motor drive and the *dc-dc* power converter with the supercapacitors. The braking resistor is still used for emergency reasons. The electric motor is a gearless Permanent Magnet Synchronous Motor (PMSM), as it is mainly used in elevator applications.

It is well known that a slight variation of the voltage to the customer's point of supply is a common phenomenon in an electric grid. Although, the maximum permissible long-term

voltage deviation varies from country to country, it is bounded up to $\pm 10\%$ of the nominal voltage (EN 50160). Since the rectifier of an elevator motor drive is a common diode bridge, the dc -link voltage would vary according to supply voltage variations. This considerably influences the performance of the energy storage system and consequently the energy saving that can be attained. Therefore, if maximum exploitation of the energy storage device is required in order to improve the efficiency of elevator system, the variation of the supply ac voltage to the elevator drive should be taken into account by the supercapacitors control system.

Aim of this paper is to propose an improved control scheme for the dc - dc power converter in order to minimize the power consumption from the grid and also to attain smooth charging and discharging performance of the supercapacitors. Thus, a fuzzy-logic controller is adopted that regulates the dc -link voltage according to the supply ac grid voltage, so as the electric energy needed in motoring operation and the energy produced in braking operation would be supplied and stored, respectively, by the supercapacitor storage system. Moreover, improved performance of the supercapacitors and therefore increased energy storage capability is accomplished through the on-line adjustment of the dc -link voltage PI controller parameters according to elevator operating conditions. Specifically, the PI controller parameters are adjusted through a look-up table according to the elevator motor the load conditions. The proposed control scheme operates independently of the motor drive and therefore it can be applied to an elevator application that is already in operation. The effectiveness and the operational improvement of the proposed control system have been validated by several simulation results.

2 Energy Flow in an Elevator Application

The elevator machine can consume or produce electric energy depending of the moving direction and the load conditions. Fig. 2 shows a typical diagram of the energy flow in an elevator operation cycle. The grey area corresponds to the energy absorbed by the grid during motoring operation, while the hatched area is the generating energy during the braking operation. In conventional elevator systems, considerable energy is being lost, since the braking energy (hatched area) is dissipated in a braking resistor. This happens because, mostly, the elevator motor drives tend to use diode converter as a rectifier that is incapable of free power flow in either directions. Regenerative braking can be accomplished if the diode rectifier would be replaced with fully controlled IGBT converter. In that configuration, during motoring operation, the power flows from the grid to the motor with the front-end converter acting as a rectifier, while during the regeneration the roles are reversed and the front-end converter operates as an inverter and thus, the braking energy is recovered to the grid. However, the inverse-parallel converter would increase considerably the cost and the complexity of the drive system.

An alternative solution to the above is to temporarily accumulate the braking energy in a storage device installed at the dc -link and to recover it in the next energy demand. In this case, a dc - dc converter is needed that is responsible for the energy

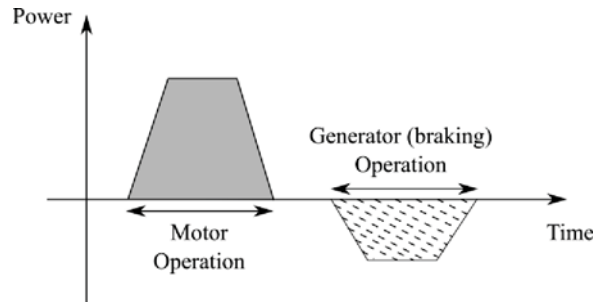

Fig. 2: Typical diagram of energy flow in an elevator operation cycle.

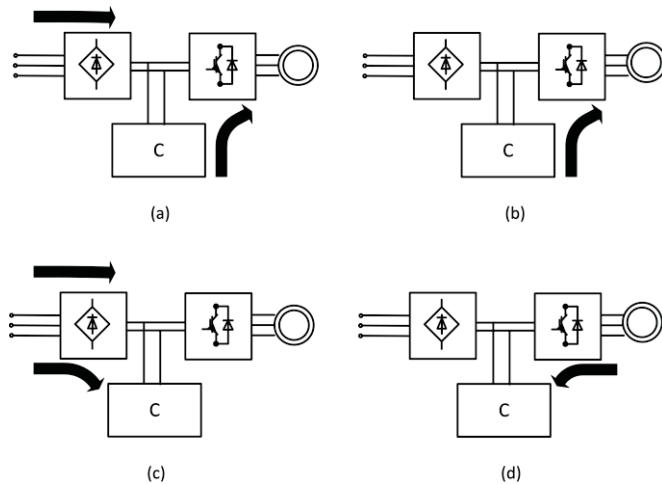

Fig. 3: Energy flow in a motor drive system, with supercapacitors as energy storage device: (a) both grid and supercapacitors supply energy to the motor, (b) motor is supplied only from the energy stored at the supercapacitors, (c) grid supply energy to the motor and for charging the supercapacitors and (d) supercapacitors are charged by the braking energy of the electric machine.

management. Fig. 3 illustrates the energy flow in a motor drive with supercapacitors as energy storage media. In Fig. 3a, the grid supplies energy to the motor in combination with supercapacitors; however, if the supercapacitors are enough charged they can provide autonomously energy to the motor drive, as shown in Fig. 3b. In Fig. 3c, the supercapacitors are initially charged from the grid and in Fig. 3d, the supercapacitors are charged from the braking energy of the electric machine.

3 Supercapacitor Bank

The supercapacitors are widely used in industry, electric vehicles, renewable energy applications (solar farms and wind turbines), individually or in combination with batteries. The advantages of supercapacitors compared to batteries are minimum maintenance, capability for operation in a wide temperature range, tolerance to overcharging and overheating, large number of charging and discharging cycles, relatively low cost and the ability to manage high power due to low internal resistance [6], [7].

The model that describes the performance of a supercapacitor to higher frequencies has the structure of a transmission line with RC elements as steps (parallel levels/branches) [8]. The number of RC steps (time constants) depends on the desired

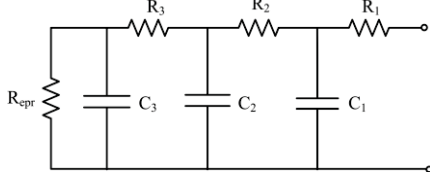

Fig. 4: Equivalent circuit of supercapacitor.

accuracy in relation to the maximum operating frequency of the supercapacitor. In this paper, a commonly used model with three parallel levels, as shown in Fig. 4, is used for modelling the array of the supercapacitors in the control scheme. The equivalent parallel resistance of the supercapacitor is denoted by R_{epr} and the equivalent series resistances are represented by R_1 , R_2 and R_3 .

The maximum energy that can be stored in a supercapacitor bank is proportional to its capacitance, as given by

$$E = \frac{1}{2} C V^2 \quad (1)$$

When the voltage range of the supercapacitor varies between the values of V_1 and V_2 , the maximum energy stored at the supercapacitor is given by

$$E = \frac{1}{2} C (V_2^2 - V_1^2) \quad (2)$$

4 DC-DC Converter

The bidirectional dc-dc converter behaves as the interface to the energy storage device and it is responsible to optimize the energy management and improve the elevator system efficiency. Basically, the topologies of bidirectional dc-dc converters are divided into two different types, isolated and non-isolated, meeting different application requirements. The isolated dc-dc converter is an attractive solution when the ratio between the dc-bus voltage and supercapacitor voltage is high. Contrarily and from the viewpoint of efficiency, size, weight and cost of the system, the non-isolated bidirectional dc-dc converter is by far more attractive than the isolated one [9]. Due to the above, the non-isolated configuration is selected in this paper.

The basic non-isolated bidirectional dc-dc converter topology is the combination of step-up stage together with a step-down stage connected in antiparallel. For the presented elevator system operation, the converter step up stage is used to step up the supercapacitor bank voltage and control the inverter input. The elevator regenerative braking is accomplished by using the converter step-down stage, which gives a path for braking current and allows the recovery of the elevator energy in the supercapacitor bank.

The ripple of the supercapacitors current must be limited to avoid overheating [10]. As the current flowing through the supercapacitors is the current of the inductance of the bidirectional dc-dc converter, the ripple current i_L should be kept small. For this purpose the continuous flow of the current is being selected as the inverter operation.

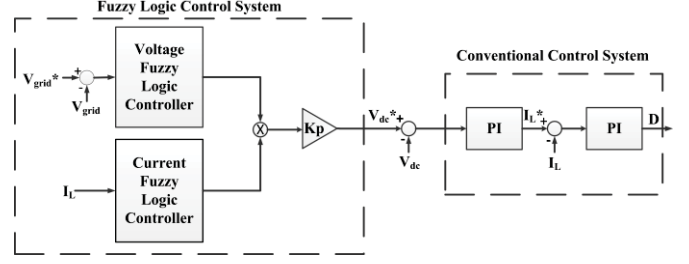

Fig. 5: Block diagram of the proposed control scheme

The ripple of the current is given by the following equation

$$\Delta I_L = \frac{V(1-D)T_s}{L} = \frac{V_{dc}D(1-D)T_s}{L} \quad (3)$$

where D is the duty-cycle of the bidirectional dc-dc converter, T_s is the sampling period and V_{dc} is the dc-link voltage. Selecting the f_s switching frequency for the converter, the value of inductance that ensures ripple current up to ΔI_L can be determined by the following formula

$$L = \frac{D(1-D)V_{dc}}{\Delta I_L f_s} \quad (4)$$

5 Control System

The block diagram of the proposed control scheme is illustrated in Fig. 5. The conventional control scheme consists of two PI controllers in cascaded topology for controlling the dc-link voltage V_{dc}^* and the coil-current of the dc-dc converter I_L^* and it finally determines the duty-cycle D for generating the IGBT's gate pulses. In the proposed control scheme, a set of two fuzzy-logic controllers is added for regulating the reference dc-link voltage so as, any variation of the supply ac grid voltage in combination with elevator mode operation is taken into account.

In the conventional system, the applied reference dc-link voltage is constant and it is chosen arbitrarily to a value greater than the nominal average dc output voltage of the rectifier. If the ac grid voltage is constant to the nominal value, the expected good performance of the supercapacitor storage system would be attained. However, if a variation of the ac grid voltage is occurred and although the supercapacitor storage system is capable to absorb braking energy or to provide energy to the motor, the performance of the energy storage system may be aggravated. Specifically, if the ac grid voltage is increased (positive deviation), the reference dc-link voltage may be lower than the dc output voltage of the rectifier and thus, although the supercapacitors are enough charged and could provide energy to the motor, the needed energy will be given by the grid. Also, in the braking operation, no-needed extra energy is flowed from the grid because the ac grid voltage and consequently the dc-link voltage is greater than the dc-link reference voltage. For similar reasons, if the ac grid voltage is reduced (negative deviation), additional energy is

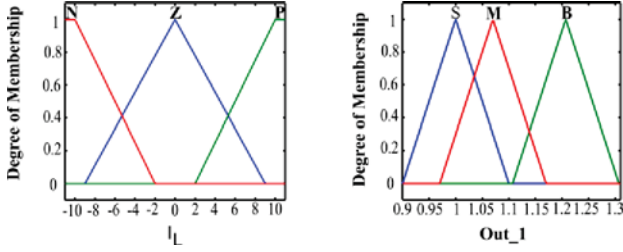

Fig. 6: Membership functions for current fuzzy-logic controller.

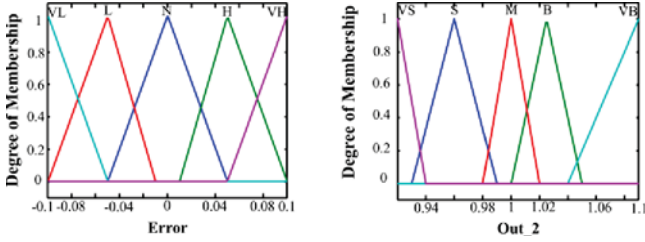

Fig. 7: Membership functions for voltage fuzzy-logic controller.

provided by the grid in order to track the reference dc -link voltage.

From the above it is concluded that, the ac grid voltage variations should be taken into account (mainly the positive deviation) in order to accomplish optimal performance of the supercapacitor energy storage system. Specifically, maximum absorption of the braking energy can be accomplished and also, the needed energy for the motor drive can be provided as possible from the supercapacitors. Therefore, the power consumption from the grid is reduced and hence, the efficiency of the elevator system is increased.

The mainly process of a fuzzy controller involves fuzzification, evaluation of control rules and finally defuzzification. Fuzzy control is of great value for problems where the system precision is an important parameter. The dc - dc converters fall into this category because they have a time-varying structure and contain elements that are nonlinear and have parasitic components [11].

The presented fuzzy-logic control scheme consists of two controllers. Both current and voltage fuzzy controller are designed as Mamdani FLC system which is one of the most popular. Also, the centroid defuzzification technique was chosen and the linguistic values are represented by triangular and trapezoid fuzzy numbers.

The current fuzzy-logic controller adjusts the reference dc link voltage as a function of the systems load cycles. The input fuzzy sets are defined as N=Negative, Z=Zero, P=Positive and the output fuzzy sets as S=Small, M=Medium, B=Big. Fig. 6 shows the fuzzy sets and the corresponding membership function description of each signal. When the electric machine operates as motor, the dc -link voltage should be increased, so as the corresponding PI controller is driven to saturation. Hence, the supercapacitor bank would produce the maximum power for the elevator system. On the other hand, when the electric machine operates as generator the dc voltage should be reduced, so as the supercapacitor would be

Parameters of the Supercapacitor Bank Model	Values
R_1, R_2, R_3	1 Ω , 0.7 Ω , 0.7 Ω
R_{epr}	220 k Ω
C_1, C_2, C_3	0.01 F, 0.15 F, 0.34 F

Table 1: Parameters of the equivalent circuit of the supercapacitor bank.

DC-link voltage PI controller parameters	
Parameters	Load conditions
$K_p = 0.55$, $K_i = 4.40$	High load
$K_p = 0.07$, $K_i = 0.56$	Low load

Table 2: DC-link voltage PI controller parameters variation.

charged by maximum rate. Finally, in elevator idle mode, the dc -link voltage should be set to an intermediate value.

The fuzzy rules for the current controller are defined as follows

$$\begin{aligned} \text{If } (I_L \text{ is } Z) \text{ then } (Out_1 \text{ is } M) \\ \text{If } (I_L \text{ is } P) \text{ then } (Out_1 \text{ is } S) \\ \text{If } (I_L \text{ is } N) \text{ then } (Out_1 \text{ is } B) \end{aligned}$$

The voltage fuzzy-logic controller adjusts the reference dc -link voltage according to grid voltage variations. The input fuzzy sets are defined as VL=Very Low, L=Low, N=Normal, H=High, VH=Very High and the output fuzzy sets as VS=Very Small, S=Small, M=Medium, B=Big, VB=Very Big. Fig. 7 shows the fuzzy sets and the corresponding membership function description of each signal. Thus, the fuzzy rules are constructed as follows

$$\begin{aligned} \text{If } (error \text{ is } VL) \text{ then } (Out_2 \text{ is } VS) \\ \text{If } (error \text{ is } L) \text{ then } (Out_2 \text{ is } S) \\ \text{If } (error \text{ is } N) \text{ then } (Out_2 \text{ is } M) \\ \text{If } (error \text{ is } H) \text{ then } (Out_2 \text{ is } B) \\ \text{If } (error \text{ is } VH) \text{ then } (Out_2 \text{ is } VB) \end{aligned}$$

The outputs of the two fuzzy-logic controllers are multiplied together and with a proportional factor K_p . The value of K_p is determined from simulation results. The final output of the fuzzy-logic control scheme is the dc -link voltage reference.

6 Simulation Model

In this paper, a 3-phase, 4.5kW, 16-poles, PMSM is used. The parameters of the supercapacitors bank are reported in Table 1. The supercapacitor bank consists of two parallel stacks, each contains 200 supercapacitor components. The operating voltage range of the supercapacitor bank is between 230 and 460 V. Thus, the capability for maximum energy storage is 39.7kJ, and the maximum power is 4.6kW. The nominal line-line voltage of the power grid is 400V. The inductance L of the coil of the dc - dc converter is 2.5 mH and the switching frequency f_s is 20 kHz. The dc -link voltage PI controller parameters, according to load conditions, are given in Table 2.

Figs. 8 and 9 compare the performance of a conventional control scheme (only, V_{dc} and I_L PI controllers are included) with the proposed control scheme (which additionally contains the fuzzy-logic controller), respectively, at a grid voltage increase

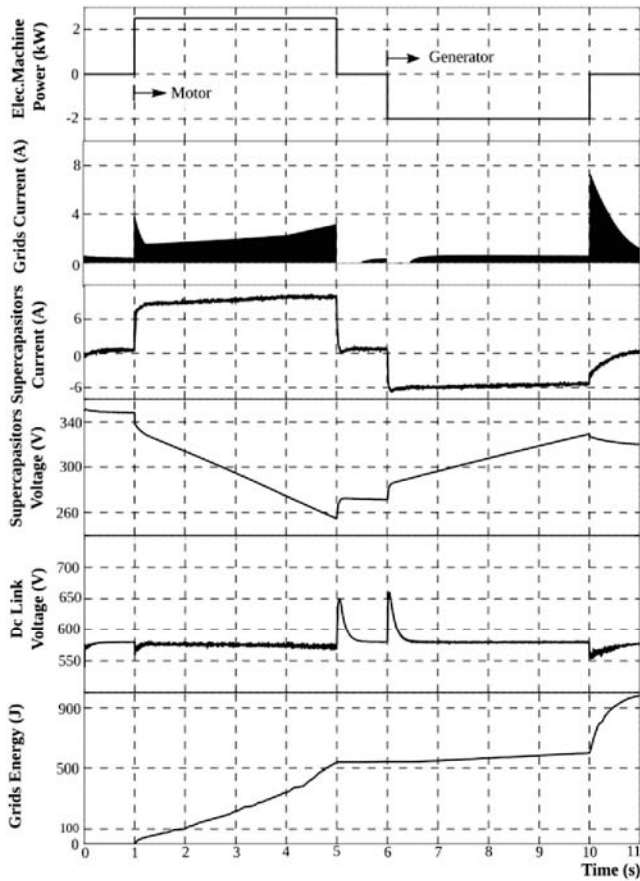

Fig.8: Performance of the conventional control scheme (only V_{dc} and I_L PI controllers are included) at grid voltage increase of 3% to the nominal voltage.

of 3% to the nominal voltage. The elevator electric machine alternates between motoring, idle and braking operation. Motor mode corresponds to a load of 2.5kW and generator mode corresponds to power supply of 2.0kW, while idle mode corresponds to no-load operation (0W). For the conventional control system, the reference dc -link voltage is constant equal to 580V.

It can be seen that in Fig. 8 which corresponds to the conventional control scheme, although the supercapacitors are enough charged and could provide energy to the motor, there is energy flow from the grid. Also, in braking operation, although the supercapacitors absorb the generating energy, there is additional flow of energy from the grid. Moreover, energy consumption is occurred even in the idle mode (especially after the braking operation), because the ac grid voltage and consequently the dc -link voltage is greater than the dc -link reference voltage. Contrarily to the above, in Fig. 9 that corresponds to the proposed control scheme, reduced energy from the grid is consumed in motoring operation and all the braking energy is absorbed by the supercapacitors. Also, much less energy is consumed in idle mode.

Figs. 10 and 11 compare the performance of a conventional control scheme (only, V_{dc} and I_L PI controllers are included) with the proposed control scheme (which additionally contains the fuzzy-logic controller), respectively, at a grid voltage decrease of 3% to the nominal voltage. As in Figs. 8 and 9, motor mode corresponds to 2.5kW, generator mode to 2.0kW

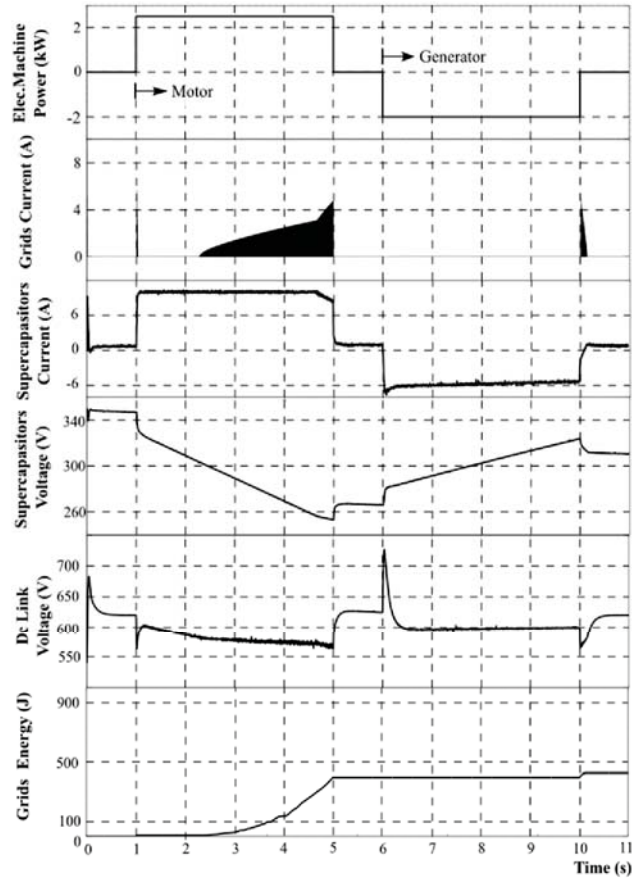

Fig.9: Performance of the proposed control scheme (which additionally contains the fuzzy-logic controllers) at grid voltage increase of 3% to the nominal voltage.

and idle mode to no-load (0W). For the conventional control scheme, the reference dc -link voltage is constant equal to 580V. It can be seen that, greater grid energy consumption is observed in the motoring mode of the conventional system compared to the proposed system; however, the consumption is lower compared to that occurred in the case ac grid voltage increase (Fig. 8). For both control schemes, no grid energy consumption occurs at the idle mode and also all the braking energy is absorbed by the supercapacitors.

7 Conclusion

In this paper, an improved control scheme for elevator motor drives with supercapacitor-based energy storage system at the dc -link has been proposed. Aim of the control scheme is to ensure power supply to the elevator motor as possible from the supercapacitors storage system and also absorption of the braking energy as possible by the supercapacitors. Additionally, on-line adjustment of the dc -link voltage PI controller parameters of the dc - dc converter according to the load conditions is provided in order to improve the supercapacitor storage system performance. The operating improvements have been validated by several simulation results.

Acknowledgments

This work was supported by European Region Development Funds and Greek National Resources (Ministry of Education,

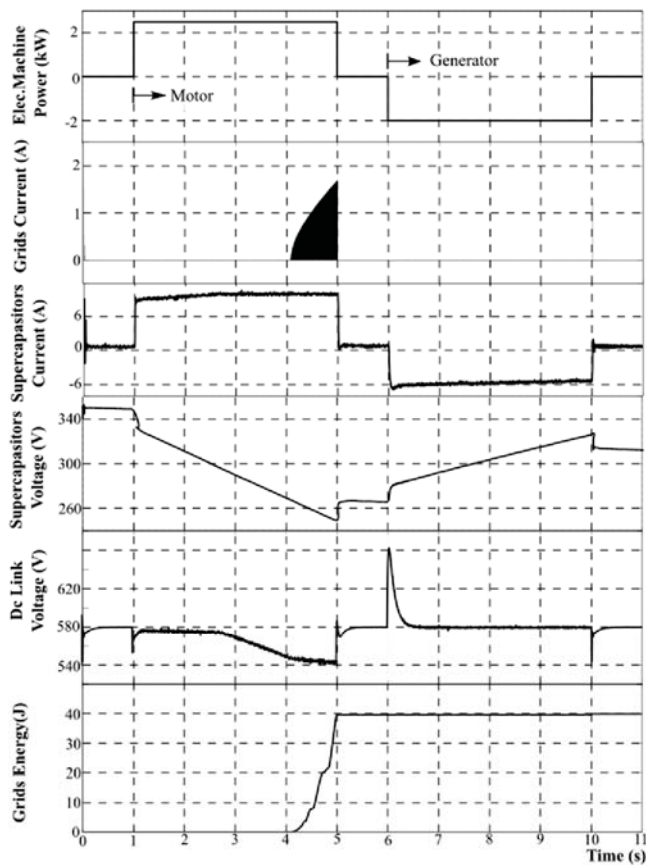

Fig.10: Performance of the conventional control scheme (only V_{dc} and I_L PI controllers are included) at grid voltage decrease of 3% to the nominal voltage.

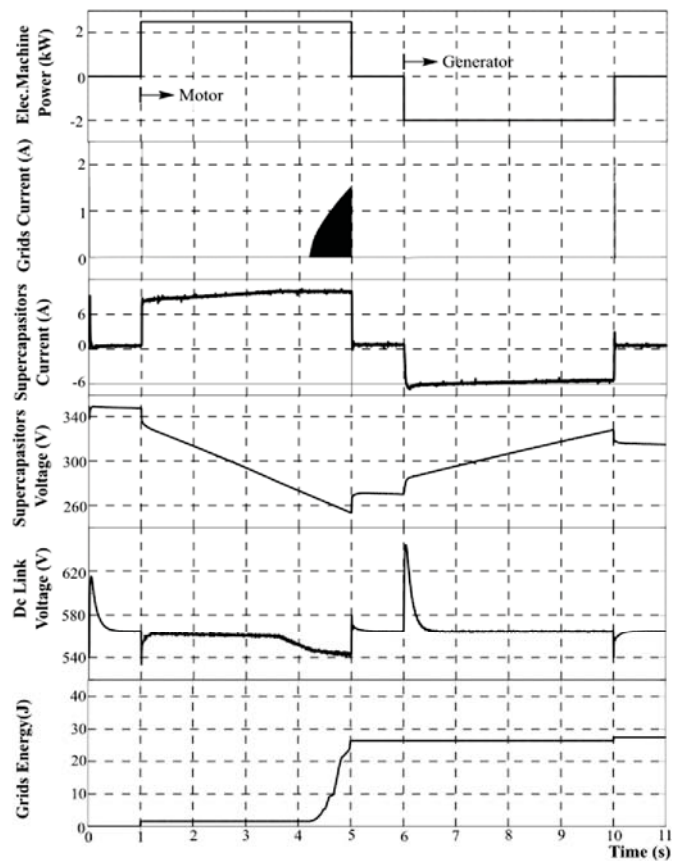

Fig.11: Performance of the proposed control scheme (which additionally contains the fuzzy-logic controllers) at grid voltage decrease of 3% to the nominal voltage.

Lifelong Learning Fund and Religious Affairs, Greece under Research Grant 09SYN-32-676 (Research Program “Cooperation 2009”).

References

- [1] Shinji Tominaga “Development of energy-saving elevator using regenerated power storage system”, *Proc. of Power Conv. Conf.*, vol. 2, pp.890-895, 2002
- [2] Rufer and P. Barrade, “A supercapacitor-based energy storage system for elevators with soft commutated interface”, *IEEE Trans. on Ind. Appl.*, vol. 38, no. 5, pp. 1151-1159, Sept. Oct. 2002.
- [3] M. Ortuzar, J. Moreno, and J. Dixon, “Ultracapacitor-based auxiliary energy system for an electric vehicle: Implementation and evaluation”, *IEEE Trans. on Ind. Electron.*, vol. 54, no. 4, pp. 2147-2156, Aug. 2007.
- [4] C. Abbey and G. Joos, “Supercapacitor energy storage for wind energy applications”, *IEEE Trans. on Ind. Appl.*, vol. 43, no. 3, pp. 769-776, May/June 2007.
- [5] Zheng Li and Yi Ruan, “A Novel Energy Saving Control System for Elevator Based on Supercapacitor Bank Using Fuzzy Logic”, in *Proc. ICEMS Intern. Conf. on Electrical Machines and Systems*, pp. 2717-2722, Oct. 2008
- [6] P.J. Grbovic, P. Delarue, P.L. Moigne, and P. Bartholomeus, “A bidirectional three-level DC-DC converter for the ultracapacitor applications”, *IEEE Trans. on Industrial Electronics*, vol. 57, no. 10, pp. 3415-3430, Oct. 2010.
- [7] V. Musolino, L. Piegari, and E. Tironi, “New full-frequency-range supercapacitor model with easy identification procedure”, *IEEE Trans. on Industrial Electronics*, vol. 60, no. 1, pp. 112-120, Jan. 2013.
- [8] P.J. Grbovic, P. Delarue, P. Le Moigne, and P. Bartholomeus, “Modeling and control of the Ultracapacitor-Based Regenerative controlled electric drives”, *IEEE Trans. on Industrial Electronics*, vol. 58, no. 8, pp. 3471-3484, Aug. 2011.
- [9] F. Caricchi, F. Crescimbin, G. Noia, and D. Pirolo, “Experimental study of a bidirectional dc-dc converter for the dc link voltage control and the regenerative braking in PM motor drives devoted to electrical vehicles,” in *Proc. IEEE APEC Intern. Conf.*, Orlando, FL, Feb. 1994, pp. 381 – 386.
- [10] H. Gualous, H. Louahlia, and R. Gallay, ‘Supercapacitor characterization and thermal modelling with reversible and irreversible heat effect’, *IEEE Trans. on Power Electronics*, vol. 26, no. 11, pp. 3402-3409, Nov. 2011.
- [11] Perry A.G., Guang Feng, Yan-Fei Liu, Sen P.C. “A Design Method for PI-like Fuzzy Logic Controllers for DC-DC Converter”, *IEEE Trans. Ind. Electronics*, vol. 54, pp. 2688-2696, Oct. 2007.