

Transient Stability of Power System by Static VAR Compensator (SVC) and Power System Stabilizers (PSS) using MATLAB/SIMULINK

Asad Naeem^{#1}, Adnan Atif^{*2}

[#]Master Student & Department of Electrical Engineering & Changsha University of Science & Technology
Changsha University of Science & Technology, Changsha, Hunan, China

Abstract

Transmission systems of present day power structures are getting to be progressively focused on in light of the fact that of developing interest and confinements on developing new era. In order for the secured operation of power system to withstand the disturbances Flexible AC transmission system (FACTS) devices are used. STATCOM (Static Synchronous Compensator) and SVC (Static VAR Compensator) are the devices belongs to FACTS family are used to exchange the power between the interconnected power system and keep the voltage and frequency constant or regulated. In this paper Modeling of transient stability and FACTS devices using MATLAB/Simulink are discussed using PSS(Power system Stabilizer).

Keywords: Transient Stability, SVC, STATCOM, PSS, MATLAB/Simulink

I. INTRODUCTION

Electric power system is meeting numerous challenges day to day due to expanding unpredictability. The power system instability was a major issue in the past. The demand of power system becomes high due to its fast and efficient improvement[1].

It is crucial to elevate the power, transmitted alongside the existing transmission offices to compensate this demand. This suggests the control of power stream in system. With the expanded stacking of transmission lines, the issue of transient dependability after a real blame can turn into a transmission force restricting element. The power framework ought to adjust to flashing framework conditions, as such; power framework ought to be adaptable. In an air conditioner power framework, the electrical era and burden must parity at all times up to some degree, the force framework is automatic. If era is less than load, the voltage and recurrence drop, and along these lines the heap goes down to equivalent the era short transmission misfortunes.

But there are just a few percent edges for such a self-directing .

Power system convey electrical from generating station to the end consumer. Electrical power is generated at generating station and it is supplied to the consumer for the local use. This transmitted power should be stable in the sense that it voltage and frequency should be stable. So power system stability is one of the major concern which should be briefly explained in this paper. In this paper Basis of power systems. Its types, components, important term used in power system and different methods adopt for voltage regulation are discussed.

Power system stability can be define as "the capability of an electric power system, for a given working circumstance, to recover a state of working synchronization in the wake of being exposed to a physical unsettling influence, with most system variables limited so that for all intents and purpose the whole system remains in place" [2]. As reported by above definition it is clear that if system neglects to get working balance then it will be called instable. There are numerous sort of insecurities exists in the present day power system, (for example, voltage, frequency and so on.) and appropriately different stabilizing methods are utilized. This stabilizing is carried out by disengaging the capacitor, inductors or mix of both after that synchronous condenser, saturated reactor, Thyristor controlled reactor, altered capacitor Thyristor controlled reactor, Thyristor exchanged capacitor were utilized; however in present days this is performed by more propelled gadgets like STATCOM, VSC, TCSC and so on. these gadgets develops the perceptive controlling and quick exchanging power device like MOSFET and IGBT the capacity of quick exchanging makes them practical for giving exact and smooth controlling. The learned controlling is performed by the complex calculations which are carried out by possibly simple circuits or chip. Despite the fact that simple gadgets performed well however in later past improvements in the semiconductor innovation makes the computerized controllers as first decision on the grounds that of their capacities and easier cost.

Now modeled and simulated by a software tool or MTLAB/SIMULINK. Each and every module of the system is modeled and then integrated later on to make an overall system, which is then simulated in SIMULINK environment in order to get the stable power system.

We will actually divide the overall system model into two sub section. In first section the synchronous machine model, Turbine and regulator, Power system stabilizer (Generic and multiband) and excitation system and the second section Load flow bus, SVC, Faults (Single phase or 3 phase), Transformer, distributed parameters line, RLC load are modeled. After that we integrate these two subsections to get the overall system.

II. POWER SYSTEM STABILIZER (PSS) MODELS

A. Generic Power System Stabilizer

When power system face disturbances which may cause electromechanical oscillation in electrical generators, these oscillations are also named as power swing. The power swing must be damped in order to get the stable system. The addition of this damping in order to maintain the power system in stable state is done with help of power system stabilizer

The input of the PSS is d_w called deviation in the machine speed or the acceleration power $P_a = P_m - P_e$ where P_m is the mechanical power and P_e is the electrical power. The output signal of PSS is the V_{stab} which may be used as additional input of Excitation system The model of the Generic Power System Stabilizer is modeled and shown in figure 1 by using a nonlinear system

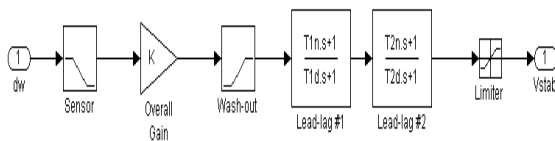

Figure 1. The Block Diagram of the Generic Power System Stabilizer

Low-pass filter, a general gain, a washout high-pass filter, a phase-compensation system, and an output limiter are the different blocks used in the PSS model. The amount of the damping developed by the stabilizer is found by K (General gain). The low

frequencies in the deviation in speed signal (d_w) is removed by the washout high pass filter. The lag in the phase angle between the excitation voltage and electrical torque is compensated by connecting two

first order lead lag blocks in cascade called phase compensation.[3,4].

B. Multi – Band Power System Stabilizer

The disturbances or power swing in electrical generators must be damped in order to stabilize the system. These oscillations are divided into four main types :

1. Local oscillations: The frequencies of these oscillations are in between 0.8 to 4 Hz. They are the oscillation between the generator and rest of power system.

2. Interplant oscillations: The oscillation between two neighboring generation station is known as interplant oscillation it frequency range is 1 to 2 Hz.

3. Inter area oscillations: These are the oscillation between two big classes of generating plants between two major groups of generating plants it frequency ranges from 0.2 to 0.8 Hz.

4. Global oscillation: The oscillation of all generator in phase is called global oscillation it frequency is below 0.2 Hz [5, 6, 7].

III. STATIC VAR COMPENSATOR (SVC)

In order to control the power flow and to improve the transient stability a static VAR compensator is used which is one of the most participants of FACTS family. The amount of reactive power injected into or absorbed from power system is the key role of SVC to regulate the terminal voltage. SVC generate reactive power (SVC capacitive) when the system voltage is low and SVC will produce SVC capacitive when the voltage of the system is high. The capacitor bank and the inductor bank which are connected to the secondary side of the coupling transformer are changed in order to produce the variation in reactive power. The single-line diagram of a static VAR compensator and a simplified block diagram of its control system is shown in figure 2. The SVC is used in three-phase power systems together with synchronous generators, motors, and dynamic loads to perform transient stability analysis and detect influence of the SVC on electromechanical oscillations and transmission capacity of the power system [3, 4, 8].

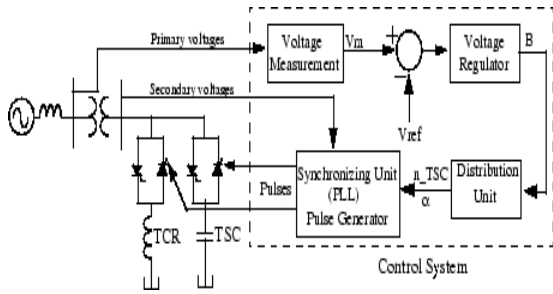

Figure 2. The Single-Line Diagram of a Static VAR Compensator and its Control System

A. SVC Mode of Operation

There are two mode of operation of SVC

- i. In voltage regulation mode.
- ii. In VAR control mode (the SVC susceptance is kept constant)

The V-I characteristics as shown in figure 3 is obtained when SVC is set to operate in voltage regulation mode.

1) V-I CHARACTERISTIC OF SVC

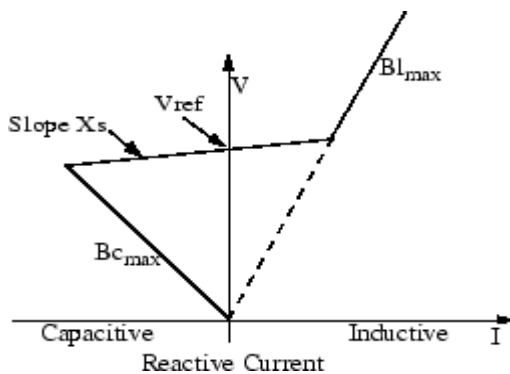

Figure 3. The V-I Characteristics of the SVC

The slope of SVC voltage current characteristics is given by the equation 1

$$slop = \frac{\Delta V_{C_{max}}}{I_{C_{max}}} = \frac{\Delta V_{L_{max}}}{I_{L_{max}}} \tag{1}$$

The V-I characteristics of SVC is explained by using equation 2, 3 and 4

$$V = V_{ref} + X_s \cdot I \tag{2}$$

Then SVC will be in regulating mode If

$$V = \frac{1}{-B_{C_{max}}} \tag{3}$$

Now if then SVC will fully capacitive. And also

$$V = \frac{1}{B_{L_{max}}} \tag{4}$$

If $B = B_{L_{max}}$ then SVC will fully inductive. The transfer function of the measuring and filtering circuit can be given by the following figure 4.

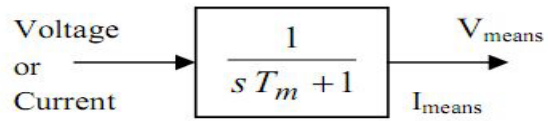

Figure 4 Transfer function of Filtering and measuring current of SVC

The susceptance of SVC is given by the following equation 5

$$B_{SVC} = \frac{B_0 (B_{TSC} + B_{TCR})}{B_0 + B_{TSC} + B_{TCR}} \tag{5}$$

Where B_0 denote the transformer susceptance

The Different parameters of SVC are given in table 1

Table 1: Typical Parameters for SVC Model

Module	Parameter	Definition	Typical value
Measuring	T_m	For time Constant	0.001-0.005s
Thyristor Control	T_d	Gating delay	0.001s
	T_b	Firing delay	0.003-0.006s
Voltage regulator	K_i	Integrator gain	K_i can be adjusted
	Slope	Steady-state error	0.01-0.05 p.u
Module	Parameter	Definition	Typical value
Measuring	T_m	For time Constant	0.001-0.005s

B. Dynamic Response of SVC

Response of SVC depends on voltage gain of voltage regulation, the droop reactance and the short circuit level. The block parameters of SVC are shown in figure 5 [4].

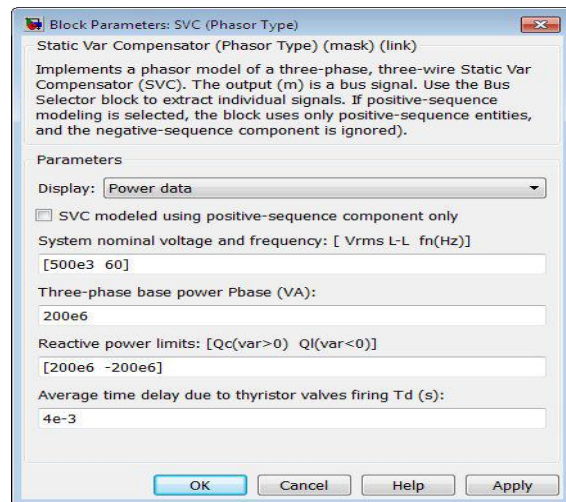

Figure 5 Power data parameters of SVC

IV. SIMULATION MODEL AND RESULTS

5000MW load center is connected over 500KV, 700Km transmission line to the 1000MW hydraulic generator. 5000MW local generator (machine M2) & 1000 MW remote plant provides power to the load center. Static Var Compensator (SVC) of 200-Mvar capacity is shunt connected to the transmission line to overcome the instability of system after occurring of faults. Power Oscillation Damping (POD) unit is not supported by SVC. Therefore for the damping of oscillations, Power System Stabilizer (PSS) & Hydraulic Turbine and Governor (HTG), are fitted into the two machines. The stabilizer modeled in regulator subsystem, are of two types based on controlling technique. Generic Model uses the acceleration method for stability, which is the difference between mechanical power and electrical power. The multiband works on the variation in speed for stability.

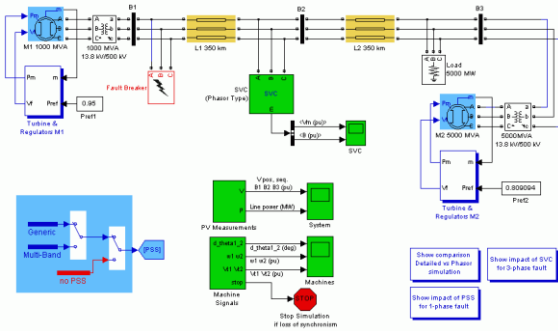

Figure 6. Overall system Simulink Model

V. SYSTEM RESPONSE WITHOUT SVC

If single phase fault occur on power system it can only be a line to ground fault, which can also categorized as incipient fault and it is in the form of leakage current, this fault can cause overheating in later stages, so it is customary to control this fault in early stages.

In this simulation SVC is made disabled by selecting VAR control mode with $B_{ref} = 0$ and the PSS block is activated by putting the value to 1 in the PSS block, we simulate the system than and the results clearly indicate that the system is stable even the SVC is out of service. The first figure shows the difference in rotor angle of the two machines. At 90 degrees maximum power is transferred. If the angle exceeds 90 degrees for long duration span, system became unstable due to machine synchronous lost.

The electrical power is less then mechanical power during fault condition, and simulating over long span of time the machine speed become oscillating with a frequency of 0.025 Hz which is indeed a very low frequency, all these occur during no fault condition on system. Now the PSS with value to 1 fails to overcome this problem and by selecting

multiband PSS with value equal to 2 in PSS block, the oscillation are damped quickly.

So it is clear from the above discussion that all single phase faults are cleared by Generic and Multiband PSS even the SVC is out of service. The system get unstable when we put the PSS (value = 0) in the PSS block or the PSS is not selected. The effect of system without SVC is illustrated in coming figure 7.

The x-axis of figure 7 shows the time and the y-axis shows the value of voltages in per unit and Line power in MW. It is clear from the figure that when fault occurs during 5sec and 6 sec, low frequency oscillation arises as a result of fault, are damped by the Power system stabilizer while the SVC is in inactive state. Thus in single phase fault, the disturbances can be easily damped by the PSS without the support of SVC which is obvious from the figure 7.

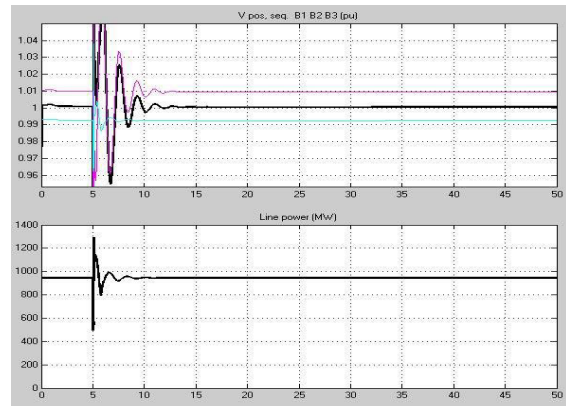

Figure 7. Single Phase Fault without SVC Support

VI. RESPONSE OF SVC & PSS FOR THREE PHASE FAULT

Now consider a situation in which a system is suffering from three phase fault, which is indeed a very severe fault then PSS without SVC cannot stabilize the system. If three phase fault occur and the SVC is still at VAR control mode with $B_{ref} = 0$, which means that SVC is not connected to the system, then the simulation results clearly indicate that the difference in rotor angle is of order of 3×360 and this show that the local and the remote generator are not synchronized on no fault conditions. In order to get stable power system under three phase fault conditions, SVC is brought into voltage regulation mode from the SVC block. Now SVC adds reactive power in order to synchronize the local and remote generator which was not achieved in early stage. After performing this action the system got stable.

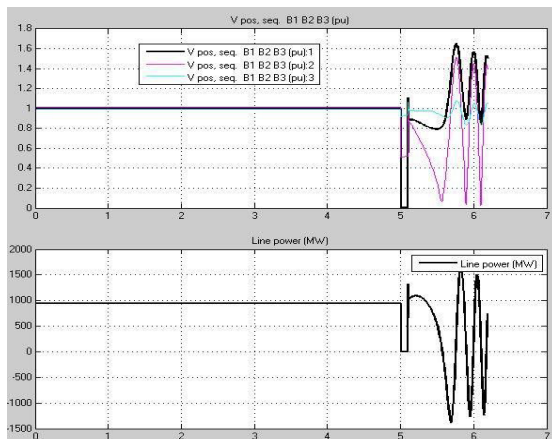

Figure 8. Three Phase Fault with SVC Inactive

Figure 8 shows the results of the case when SVC is still disabled while three phase occurs. The machines losses synchronism and thus the system become unstable and operation is stopped. This is clear from the figure 8. The x-axis and y-axis shows time, voltage and power values respectively.

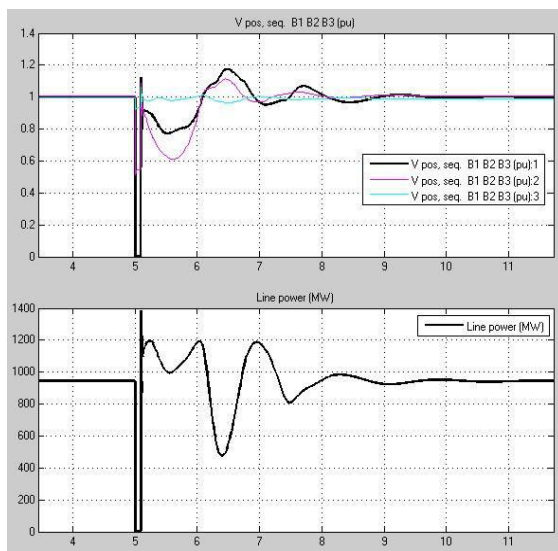

Figure 9 System Stability with SVC for Three Phase Fault

Figure 9 shows the impact of SVC in service for three phase fault. During fault conditions, SVC injects Voltage, bringing back machine in synchronization. Thus overall system becomes stable and power stability is achieved.

VII. CONCLUSION

It is shown that generic PSS can clear the single phase fault alone but it cannot handle the low frequency oscillations and the system got unstable, if multiband and generic PSS are both selected then the low and highly frequency oscillation are damped together and the system became stable. Also the impact of three phase faults on system are discussed

which are cleared by the Two PSS without SVC but stability is not achieved in this case because speed synchronization of both machine are lost in three phase condition and the system goes unstable in such scenario, and the synchronization loss problem which make the system unstable is overcome by connecting the SVC in voltage regulation mode. Which balance the speed of the two machines in order to stabilize the said system.

REFERENCES

- [1] W. Hu, S. Member, C. Wang, S. Member, Z. Chen, S. Member, and B. Bak-jensen, "Power System Transient Stability Improvement Using Demand Side Management in Competitive Electricity Markets," pp. 1 - , 2006.
- [2] D. Electrical and P. Engineering, Wind integration into hydro dominant Power System.2013.
- [3] Huang Shao-Ping, "Modeling and Simulating for Transient Stability Analysis of Power System using Dynamic Phasor" The 1st International Conference on Information Science and Engineering (ICISE2009).
- [4] Lin Xu, "Coordinated Control of SVC and PSS for Transient Stability Enhancement of Multi-Machine Power system" TELKOMNIKA, Vol. 11, No. 2, February 2013.
- [5] Prabha Kundur, "Definition and Classification of Power System Stability" IEEE TRANSACTIONS ON POWER SYSTEMS © 2004 IEEE
- [6] Narain G. Hingorani, Laszlo Gyugyi, "Understanding FACTS : concepts and technology of flexible AC transmission systems"
- [7] Mehrdad Ahmadi Kamarposhti, "Comparison of SVC and STATCOM in Static Voltage Stability Margin Enhancement," World Academy of Science, Engineering and Technology, 2009
- [8] Muralidhar Verma¹, Shriyansh Jain², "IMPROVING POWER SYSTEM TRANSIENT STABILITY BY USING FACTS DEVICES" International Journal For Technological Research In Engineering Volume 4, Issue 9, May-2017