



Standard Test Method for Magnetic Properties of Magnetic Amplifier Cores¹

This standard is issued under the fixed designation A 598/A 598M; the number immediately following the designation indicates the year of original adoption or, in the case of revision, the year of last revision. A number in parentheses indicates the year of last reapproval. A superscript epsilon (ϵ) indicates an editorial change since the last revision or reapproval.

1. Scope

1.1 This test method covers the determination of the magnetic performance of fully processed cores for magnetic amplifier-type applications.

1.2 Tests may be conducted at excitation frequencies of 60, 400, 1600 Hz, or higher frequencies.

1.3 Permissible core sizes for this test method are limited only by the available power supplies and the range and sensitivity of the instrumentation.

1.4 At specified values of full-wave sinusoidal-current excitation, H_{\max} , this test method provides procedures of determining the corresponding value of maximum induction, B_{\max} .

1.5 At specified values of half-wave sinusoidal-current excitation, this test method provides procedures for determining the residual induction, B_r .

1.6 At increased specified values of half-wave sinusoidal-current excitation, this test method provides procedures for determining the dc reverse biasing magnetic field strength, H_1 , required to reset the induction in the core material past B_r to a value where the total induction change, ΔB_1 , becomes approximately one third of the induction change, $2 B_p$. It also provides procedures for determining the additional dc reset magnetic field strength, ΔH , which, combined with H_1 , is the value required to reset the induction in the core material past B_r to a value where the total induction change, ΔB_2 , becomes approximately two thirds of the induction change $2 B_p$.

1.7 This test method specifies procedures for determining core gain from the corresponding biasing and induction changes, ΔH and ΔB .

1.8 This test method covers test procedures and requirements for evaluation of finished cores which are to be used in magnetic-amplifier-type applications. It is not a test for basic-material magnetic properties.

1.9 This test method shall be used in conjunction with Practice A 34/A 34.

1.10 Explanations of symbols and abbreviated definitions appear in the text of this test method. The official symbols and definitions are listed in Terminology A 340.

1.11 The values and equations stated in customary (cgs-emu and inch-pound) or SI units are to be regarded separately as standard. Within this test method, SI units are shown in brackets. The values stated in each system may not be exact equivalents; therefore, each system shall be used independently of the other. Combining values from the two systems may result in nonconformance with this test method.

1.12 *This standard does not purport to address all of the safety concerns, if any, associated with its use. It is the responsibility of the user of this standard to establish appropriate safety and health practices and determine the applicability of regulatory limitations prior to use.*

2. Referenced Documents

2.1 *ASTM Standards:*²

A 34/A 34M Practice for Sampling and Procurement Testing of Magnetic Materials

A 340 Terminology of Symbols and Definitions Relating to Magnetic Testing

A 596/A 596M Test Method for Direct-Current Magnetic Properties of Materials Using the Ballistic Method and Ring Specimens

3. Terminology

3.1 *Definitions*— Below is a list of symbols and definitions as used in this test method. The official list of symbols and definitions may be found in Terminology A 340. (See Table 1 where indicated).

3.2 *Symbols:*

¹ This test method is under the jurisdiction of ASTM Committee A06 on Magnetic Properties and is the direct responsibility of Subcommittee A06.01 on Test Methods.

Current edition approved May 1, 2007. Published January 2008. Originally approved in 1969. Last previous edition approved in 2002 as A 598/A 598M–02.

² For referenced ASTM standards, visit the ASTM website, www.astm.org, or contact ASTM Customer Service at service@astm.org. For *Annual Book of ASTM Standards* volume information, refer to the standard's Document Summary page on the ASTM website.

TABLE 1 Standard Values of ΔB , ΔB_1 , and ΔB_2 for the Commonly Used Materials

Core Material ^A	ΔB_1 (for Test of 10.5)		ΔB_2 (for Test of 10.4)		ΔB or ($\Delta B_2 - \Delta B_1$)	
	kG	Tesla	kG	Tesla	kG	Tesla
Supremendur	14	1.4	28	2.8	14	1.4
Oriented silicon-iron	10	1.0	20	2.0	10	1.0
50 % nickel-iron:						
Oriented	10	1.0	20	2.0	10	1.0
Nonoriented	8	0.8	16	1.6	8	0.8
79 % nickel-iron	5	0.5	10	1.0	5	0.5
Supermalloy	5	0.5	10	1.0	5	0.5

^A Values for other materials may be used by mutual agreement between seller and purchaser.

- A = cross-sectional area of test specimen core material, cm² [m²].
- A_1 = ac ammeter for primary circuit, half-wave, average-responsive, A.
- A_2 = dc ammeter for H_1 biasing winding, A.
- A_3 = dc ammeter for H_2 biasing winding, A.
- A_4 = dc milliammeter for ac voltage calibrator, V.
- $B_{max} - B_r$ = change in test specimen induction, under half-wave sinusoidal-current excitation specified for this measurement.
- B_m = maximum induction in a sine-current SCM ac flux-current loop Gauss [Tesla] (**Note 1**).
- B_p = maximum value of induction in the sine-current half-wave CM flux-current loop, for the reset test Gauss [Tesla] (**Note 1**).
- B_r = residual induction in an ac sine-current flux-current loop Gauss [Tesla].
- ΔB = change in magnetic induction Gauss [Tesla] (**Table 1**).
- ΔB_1 = change in induction in the flux-current loop during H_1 test Gauss [Tesla] (**Table 1**).
- ΔB_2 = change of induction in the flux current loop during H_2 test Gauss [Tesla] (**Table 1**).
- CM = cyclic magnetization (see Terminology **A 340**).
- D_1 and D_2 = solid state diodes or other rectifiers.
- D_3 to D_6 = silicon diodes.
- d = lamination thickness, cm [m].
- E_{avg} = average value of voltage waveform, V.
- f = frequency of test, Hz.
- G = core gain $\Delta B_2 - B_1/H_2, -H_1,$

$$\frac{\text{Gauss} \left[\frac{T}{\text{A/m}} \right]}{\text{Oe} \left[\frac{\text{A/m}}{\text{A/m}} \right]}$$
- H_c = coercive field strength in an SCM flux-current loop Oe [A/m].
- H_{max} = maximum magnetic field strength in a sine-current SCM ac flux-current loop, Oe [A/m] (**Note 1**).
- H_p = maximum value of the sine-current ac magnetic field strength for the CM reset tests, Oe [A/m] (**Note 1**).
- H_1 = dc biasing (reset) magnetic field strength for the H_1 test point, Oe [A/m].
- H_2 = dc biasing (reset) magnetic field strength for the H_2 test point, Oe [A/m].
- ΔH = change in dc biasing (reset) magnetic field strength, Oe [A/m].

- N_1 = test winding primary, ac excitation winding, turns.
- N_2 = test winding primary, dc H_1 biasing winding, turns.
- N_3 = test winding primary, dc H_2 biasing winding, turns.
- N_4 = test winding secondary, ΔB pickup winding, turns.
- SCM = symmetrical cyclic magnetization (see Terminology **A 340**).

NOTE 1—Note that H_{max} and B_{max} , as used in this test method, are maximum points on the sine-current SCM or corresponding half-wave CM flux-current loops. Also, that H_p and B_p are maximum points on a CM flux-current loop corresponding to the ac half-wave sine current which is established in the exciting winding, N_1 , and held constant, during the dc current measurements for H_1 , H_2 , or ΔH . These definitions are different from those used for the same symbols in Terminology **A 340** for use with dc or sinusoidal-flux ac measurements.

4. Summary of Test Method

4.1 This test method uses the procedures commonly referred to as the “Constant Current Flux Reset Test Method” (C.C.F.R.). For graphic representation of the magnetic amplifier core test see **Appendix X3**.

4.2 Under its provision, a specific predetermined value of sinusoidal-current excitation, H_{max} , (**Table 2**) is established and the corresponding induction change is measured to determine the value of maximum induction which is then designated B_{max} .

4.3 The excitation is then changed to a unidirectional half-wave sinusoidal current of the same magnitude as that used for determining maximum induction. The change in induction under this excitation then is measured to determine the property designated ($B_{max} - B_r$), or the change between the maximum and residual values of induction.

4.4 The ac half-wave sinusoidal-current excitation, as measured in the ac exciting winding, is then increased to a new value, designated H_p (**Table 2**), which causes the ac induction in the test specimen to rise to a new value which is designated B_p . A dc reverse-polarity magnetic field strength is then applied. The opposing dc magnetic field strength resets the flux or induction in the core material, between each half cycle of ac magnetization, to a value that provides the specified ΔB_1 induction change (**Table 1**). This dc excitation, designated H_1 , is the value required to reset past B_r to a point that provides the specified change in induction of ΔB_1 which is approximately equal to one third of $2 B_p$. This value of H_1 has some correlation to the coercive field strength, H_c , of the material.

TABLE 2 Standard Values of Peak Sine Current Magnetic Field Strength to Be Established for Testing the Commonly Used Materials

Core Material ^A	Full-Wave SCM Value of H_{max} (for Measurement of B_{max} in Test of 10.2)		Half-Wave CM Value of H_{max} (for Measurement of B_{max} – B_r in Test of 10.3)		Half-Wave CM Value of H_p , (for Determining H_1 and H_2 or ΔH in Testing of 10.4 and 10.5 and adjustments of 10.1)	
	Oe	A/m	Oe	A/m	Oe	A/m
Supermendur	3	240	3	240	6	480
Oriented silicon-iron	3	240	3	240	6	480
50 % nickel-iron	1	80	1	80	2	160
79 % nickel-iron	0.5	40	0.5	40	1	80
Supermalloy	0.25	20	0.25	20	0.5	40

^A Values for other materials may be used by mutual agreement between seller and purchaser.

4.5 Holding the same increased value of ac half-wave sinusoidal-current excitation, as described in 4.4, the dc reverse-polarity excitation is increased by the amount ΔH and the total value of dc reverse biasing ($H_1 + \Delta H$) is designated H_2 . It is the value of dc reverse biasing required to reset the flux between ac magnetizing cycles to a value which provides the specified total change in induction of ΔB_2 (Table 1) that is approximately equal to two thirds of $2 B_p$.

4.6 From the change in dc bias ΔH and the changes in induction ΔB corresponding to the change between the H_1 and H_2 operating points, the core gain may be determined. It is usually reported as a ΔH value for the core. When required for special reasons, it may be reported in terms of core gain, G (see 11.5).

4.7 It is standard practice to assign values to the change of induction ΔB_1 and ΔB_2 (Table 1). This in turn determines the magnitude of the H_1 and H_2 biasing values corresponding to these changes of induction.

4.8 The normal test specimen may have any size or shape. When used specifically to evaluate materials for core construction, it is limited in size, weight, and method of manufacture.

4.9 Heat treatment appropriate to the core material and core construction may be required before test.

5. Significance and Use

5.1 The method of excitation simulates, to a practical degree, the operation of a magnetic core in a self-saturating

magnetic amplifier. The properties measured are related to the quality of performance of the cores in magnetic amplifiers and are useful for the specification of materials for such cores.

6. Apparatus (see Fig. 1)

6.1 *Sinusoidal Voltage Supply*—The source of excitation shall be an ac source of sinusoidal voltage which shall have sufficient power to magnetize the largest core to be examined to the levels of excitation as specified in Table 2. Its harmonic distortion under load shall be less than 3 %. Its frequency should be constant to within 1 % or less. Standard test frequencies are 60, 400, and 1600 Hz.

6.2 *Series Impedance, Z_1 , or Resistor, R_1* —This impedance should provide a voltage drop much larger than the voltage appearing across the excitation winding. Then, the distortion of current waveform as a result of the nonlinear impedance of the core will be minimized. It may be a power resistor for small size cores. For larger cores, a series resonant circuit may be used, which reduces the voltage requirements of the power source. The voltage across this impedance or a reactive element in Z_1 must be greater than 25 times the average voltage induced in the excitation turns, N_1 .

6.3 *Diodes (Note 2), D_1 and D_1* may be fast solid state devices (Note 3), high-vacuum rectifiers, or Schottky rectifiers.

NOTE 2—During the interval between half-wave pulses, when the excitation should be nominally zero, the average leakage current shall be less than 0.1 % of the peak value of excitation current during a pulse.

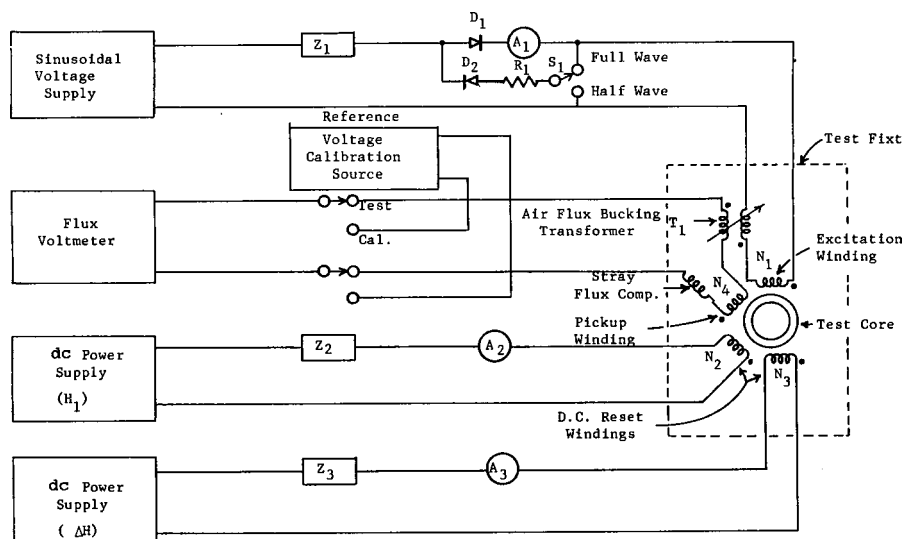

FIG. 1 Basic Diagram for Magnetic Amplifier Core Test

NOTE 3—In the case of solid-state devices, a capacitive charging pulse of reverse current is sometimes observed, particularly at the higher frequencies. Its integrated value, in ampere-seconds, at any test frequency shall be limited to 1.0 % of the ampere-seconds of the exciting half-wave.

6.4 The test fixture shall be composed of four sets of windings enclosing the core and a means of compensating for air-flux effect in induced voltage in N_4 .

6.4.1 The exciting winding N_1 shall contain as small a number of turns as practical to limit the exciting-current waveform distortion (see 6.1).

6.4.2 The B -coil, pickup winding, N_4 , may contain any convenient number of turns. This winding shall be maintained in a fixed position in relation to the excitation windings to eliminate variations in the air-cored inductive or capacitive coupling between them. Compensation for such coupling may be accomplished with the air-cored bucking transformer, T_1 .

NOTE 4—The coils of the test fixture, including the air-cored bucking transformer, T_1 , if used, shall be initially adjusted such that the voltage coupling between the exciting and pickup windings will be minimized when no specimen is in place, and maximum full-wave exciting current for a given-size core is applied. The cancellation will be considered adequate when the flux voltmeter indicates the equivalent of 15 G [0.0015 T] or less for that size core. The pickup circuit should be shielded from stray fields, when this cannot be accomplished an adjustable coil may be used to buck out voltages picked up from external fields (see 10.1).

6.4.3 The dc reset windings shall use a small number of turns to help minimize the ac transformer loading of the test core. The impedances, Z_2 and Z_3 , described in 6.9 and 11.5 also help to limit this loading effect to acceptable values.

6.5 Flux Voltmeter:

6.5.1 The flux voltmeter must respond to the true average value of the pickup-winding voltage. The average value of the voltage waveform is directly proportional to the total change of magnetic flux in the core. The flux-voltmeter accuracy shall be 1 % or better.

NOTE 5—For medium- or small-size cores, the ordinary rectifier ac voltmeters are not sensitive enough to accurately measure $B_{\max} - B_r$, and conventional average-responsive vacuum-tube voltmeters are subject to excessive errors as a result of the extremely peaked nature of the voltage waveform and to the high ratio of peak to average values. Therefore, special instruments must be used. Some typical schemes appear in Appendix X1.

6.5.2 The input impedance of the flux voltmeter as connected to the pickup winding of the core shall exceed the value of Z for any coil load as specified in 11.6.

6.6 Calibration Source—An adequate means shall be provided to calibrate the flux voltmeter. A source of accurately known ac voltage, or the output of a core whose saturation has been carefully measured by dc ballistic methods may be used. The reference voltage calibrator shown in Appendix X2 provides a suitable voltage source having a waveform approximating that of cores tested by this test method, with a test method for determining the average voltage (see 9.2).

6.7 DC Power Supply for H_1 —This power supply shall provide sufficient voltage to overcome the voltage drop across impedance, Z_2 , and sufficient current capacity to saturate any core to be tested. The rms value of the ac ripple of the dc power-supply voltage shall not exceed 0.25 % of the test

voltage required under the conditions of maximum or minimum dc load currents.

6.8 DC Power Supply for ΔH —This power supply shall provide sufficient voltage to overcome the voltage drop of impedance, Z_3 , and sufficient current capacity to provide ΔH for any core to be tested. Its rms ripple voltage shall not exceed 0.25 % of the test voltage required under the conditions of maximum or minimum dc load currents.

6.9 AC Blocking Impedances, Z_2 and Z_3 —These impedances are dc current-passing elements that reduce the ac loading effects of the H_1 and ΔH windings and their dc power supplies to acceptable limits. Minimum values for impedances Z_2 or Z_3 may be calculated from the equation of 11.6.

6.10 Ammeters:

6.10.1 Ammeter, A_1 —This ammeter is normally a dc instrument of the d'Arsonval indicating type or a dc digital voltmeter reading voltage across a precision resistor. It shall have a full-scale accuracy of at least ± 1.0 % and shall be capable of calibration as a full-wave or half-wave peak-indicating ammeter.

6.10.2 Ammeters, A_2 and A_3 —These instruments are dc ammeters or dc digital voltmeters reading voltages across precision resistors and must have a full-scale accuracy of at least ± 0.5 %. For measurement of properties of very-high-gain cores, these ammeters must have an accuracy of at least ± 0.25 % of full scale.

6.11 Resistor, R_1 —This resistor compensates for the ammeter's impedance and nonequality of the two diodes. It is adjusted to provide equal values of crest current, in the two half waves, when full-wave excitation is being used.

6.12 Switch, S_1 —This switch provides means for applying either full- or half-wave excitation to the core while maintaining full-wave loading on the power source.

7. Sampling

7.1 Unless otherwise agreed upon, test specimens that represent a lot or more than one core shall be selected in accordance with Practice A 34/A 34M.

8. Test Specimen

8.1 The test specimen may be a core or lamination stack of any size or shape which has been designated for use in magnetic-amplifier applications.

9. Calibration of Test Equipment

9.1 The individual instruments used to measure the three excitation currents must be calibrated against suitable dc reference standards according to good laboratory practice.

9.1.1 Ammeter A_1 , used to measure the full-wave and half-wave ac magnetizing currents, is an average-responsive ammeter connected in such a manner that for both measurements it sees only the positive unidirectional half-cycle current wave trains. This dc instrument is calibrated to indicate the average value of the ac half-wave where $I_{dc} = I_{avg}$, and the peak of the current wave trains is obtained as follows:

$$I_p = \pi I_{avg}$$

where:

I_p = peak value of half-wave ac exciting current, A and
 I_{avg} = average value of ac half-wave exciting current, A.

9.1.2 Ammeters A_2 and A_3 are dc instruments used to measure direct current. They require accurate calibration but no conversion factors.

9.2 The ac fluxmeter may be calibrated by either a reference core or a reference-voltage calibrator.

9.2.1 A reference core is one whose flux change is known or can be measured. Such measurements can be made by dc ballistic methods.³ A supermalloy core or suitable equivalent prepared from 0.001-in. [25- μ m] thick material excited to a peak excitation of 10 Oe [796 A/m] is suggested. This reference core is placed in the test fixture and excited with the magnetic field strength for which the flux change is known. The ac flux voltmeter is then calibrated in terms of the known flux change.

9.2.2 The reference-voltage calibrator of Appendix X2 develops a known average voltage having a waveform approximating that of the induced voltage in winding N_4 of Fig. X2.1 for the measurement of B_{max} .

10. Procedure

10.1 Set switch S_1 to the full-wave position and turn all dc power supplies to zero current. Then, with no core in the test jig, raise the level of the ac sinusoidal current in the excitation winding, N_1 , to the value which produces the peak excitation, I_p , required in Table 1 for the measurement of B_p . Then adjust the coupling of the air flux compensator, T_1 , to give a minimum reading on the flux voltmeter scale (Note 4). The position of the stray-flux compensator must also be adjusted to provide the lowest possible residual-flux voltmeter reading. The exciting current, I_p , value required for this measurement may be calculated from the equation of 11.1.

10.2 Place a test specimen in the test fixture, and with the value of full-wave SCM sinusoidal-current excitation, I_p (calculated from specified H_{max} of Table 2), flowing through the excitation winding, N_1 , observe the flux-voltmeter reading across winding, N_4 . This voltage corresponds to a total flux change from forward B_{max} to reverse B_{max} (or $2 B_{max}$ in terms of half-wave parameters).

10.3 Operate switch S_1 to the half-wave excitation position and maintain the same value of peak-excitation current, I_p (used in 9.2), so that the half-wave (CM) value of H_{max} equals the previous full-wave (SCM) value of H_{max} . Again observe and record the flux-voltmeter reading across winding N_4 . This voltage is proportional to the flux-density shift in the specimen material during cyclic changes from maximum to residual induction and is the measure for the quantity $B_{max} - B_r$.

10.4 With switch S_1 remaining in the half-wave excitation position, readjust the excitation current, I_p (as calculated for 10.1), to a value that provides the peak magnetic field strength specified in Table 1 which is to be maintained during measurements for the parameters, H_1 , ΔH , and ΔB . Then adjust the dc level (from the H_1 power supply) in winding N_2 until the flux voltmeter indicates the voltage that is induced when the desired

ΔB_1 (as shown in Table 1) has been established. This reverse dc biasing current, I_2 , in amperes is used to calculate the value of H_1 in oersteds or A/m (see 11.3).

10.5 With switch S_1 remaining in the half-wave position and excitation current, I_p , and reverse-biasing current, I_2 , held to the values given in 10.4, adjust the dc current level (from the ΔH power supply) in winding N_3 until the flux voltmeter indicates the voltage which is induced when the desired ΔB_2 (as shown in Table 1), has been established. This reverse dc biasing current, I_3 , in amperes is used to calculate the value of ΔH oersteds or A/m (see 11.3). This current represents the change in reverse dc biasing current (or biasing field ΔH oersteds or A/m) which causes the induction resulting from the ac excitation to change by the value of ΔB G.

10.6 When a very stable dc power supply is used with 1-dc ammeter of the 0.1 % class or better, this combination with a single dc winding, N_2 , may be used for both the H_1 and H_2 or ΔH determinations.

10.7 In this test method, the coercive field strength H_c parameter is not measured directly or calculated from other parameters. An approximate correlation may be found with the parameter H_1 .

11. Calculations

11.1 Table 1 specifies the values of full-wave or half-wave sinusoidal-current magnetic field strength to be used in testing various materials. The following equation is used to calculate the peak value of full-wave or half-wave sinusoidal current required to establish the desired magnetic field strength. Where for full-wave excitation,

$$I_p = \ell_1 H_{max} / 0.4\pi N_1, H_{max} \text{ in Oe}$$

$$I_p = \ell_2 H_{max} / N_1, H_{max} \text{ in A/m}$$

and for half-wave excitation,

$$I_p = \ell_1 H_p / 0.4\pi N_1, H_p \text{ in Oe}$$

$$I_p = \ell_2 H_p / N_1, H_p \text{ in A/m}$$

where:

I_p = peak value of current reached during a cycle of the sinusoidal full-wave or half-wave exciting current, A,

ℓ_1 = mean magnetic path length of the test specimen, cm, and

ℓ_2 = mean magnetic path length of the test specimen, m.

H_{max} = predetermined peak value of magnetic field strength H_{max} to be used for a particular test (see Table 2),

H_p = predetermined peak value of magnetic field strength, H_p , to be used for a particular test (see Table 2), and

N_1 = number of turns used in the excitation winding.

11.2 When the peak current ammeter used is a dc average-responsive ammeter, the following equation shall be used to calculate the scale indication corresponding to the desired value of peak magnetic field strength, H_{max} . Where for full-wave excitation,

³ See Practice A 34/A 34M, Terminology A 340, and Test Method A 596/A 596M.

$$I_{\text{avg}} = \ell_1 H_{\text{max}} / 0.4\pi N_1 \pi, H_{\text{max}} \text{ in Oe}$$

$$I_{\text{avg}} = \ell_2 H_{\text{max}} / N_1 \pi, H_{\text{max}} \text{ in A/m}$$

and for half-wave excitation,

$$I_{\text{avg}} = \ell_1 H_p / 0.4\pi N_1 \pi, H_{\text{max}} \text{ in Oe}$$

$$I_{\text{avg}} = \ell_2 H_p / N_1 \pi, H_{\text{max}} \text{ in A/m}$$

where:

- I_{avg} = average value of alternating current as indicated on the dc average responsive instrument scale, A;
- ℓ_1 = mean magnetic path length of the test specimen, cm; and
- ℓ_2 = mean magnetic path length of the test specimen, m.
- H_{max} = peak value of magnetic field strength, H_{max} , from **Table 2**;
- H_p = peak value of magnetic field strength, H_p , from **Table 2**; and
- N_1 = number of turns on excitation winding.

11.3 The values of reverse dc biasing magnetic field strength for the H_1 and ΔH determinations may be calculated from the following:

$$H_1 = 0.4\pi N_2 I_2 / \ell_1 \text{ in Oe, } H_1 = N_2 I_2 / \ell_2 \text{ in A/m}$$

$$\Delta H = 0.4\pi N_3 I_3 / \ell_1 \text{ in Oe, } \Delta H = N_3 I_3 / \ell_2 \text{ in A/m}$$

where:

- H_1 = dc biasing (reset) magnetic field strength from coil N_2 (H_1 testpoint);
- ΔH = dc biasing (reset) magnetic field strength from coil N_3 (N_2 testpoint);
- N_2 = magnetizing coil for H_1 dc reverse biasing, turns;
- N_3 = magnetizing coil for H_2 dc reverse biasing, turns;
- I_2 = direct current required in N_2 for the H_1 testpoint, A;
- I_3 = direct current required in N_3 for the H_2 testpoint, A; and
- ℓ_1 = mean magnetic path length of the test specimens, cm.

11.4 The value of ΔB may be calculated as follows:

$$\Delta B = \Delta B_2 - \Delta B_1$$

where:

- ΔB_1 = total B swing for the H_1 testpoint and
- ΔB_2 = total B swing for the H_2 testpoint.

11.5 The gain factor for a core is usually expressed in terms of the ΔH test value required to change the induction swing from the value of ΔB_1 to that of ΔB_2 (see 11.3). This value is very useful for evaluating the quality of cores made from a specific material. For quality comparisons between cores made from two different types of material or for other isolated cases, it may be desirable to express the gain factor of the core as a ratio between ΔB and ΔH as follows:

$$G = \Delta B / \Delta H, G[T] = \Delta B / \Delta H$$

where:

- G = core gain, G/Oe, or G[T] = core gain, Tesla/A/m.

11.6 The minimum value of impedance that is allowable for an external circuit or instrument which is to be connected to a test winding can be determined from the following equation:

$$Z = 2\pi f N^2 \frac{A}{\ell_1} \frac{\Delta B}{\Delta H} \times 10^{-5} \text{ cnst. units}$$

$$Z = 5f N^2 \frac{A}{\ell_1} \frac{\Delta B}{\Delta H} \times 10^{-3} \text{ SI units}$$

where:

- Z = total impedance, looking externally from the winding terminals, Ω ;
- f = frequency, Hz;
- N = number of turns in the test winding to be connected to the circuit impedance or instruments;
- A = cross-sectional area of the core material, cm^2 [m^2]; and
- ℓ_1 = mean magnetic path length of the core, cm [m].

11.7 The core material area, A , is normally determined from the nominal core dimensions and lamination factors of **Table 3** and **Table A1.2**. When the core area is not known, it may be determined by calculation from dimensions and stacking factor.

11.8 The mean path length of the core material shall be determined from the manufacturer's published dimension or from measured dimensions.

11.9 The flux-voltmeter scale may be calibrated to indicate ΔB changes directly from its scale reading (**Appendix X2**) or to indicate average volts. Voltages corresponding to the desired induction or change in induction may be calculated as follows:

$$E_{\text{avg}} = 2(\Delta B) N_4 f A \times 10^{-8} \text{ cnst. units}$$

$$E_{\text{avg}} = 2\Delta B N_4 f A \text{ SI units}$$

where:

- E_{avg} = average value of voltage induced in winding N_4 , V;
- ΔB = change in induction in the magnetic core material, G [T];
- N_4 = number of turns in winding N_4 ;
- f = frequency, Hz; and
- A = cross-sectional area of the core material, cm^2 [m^2].

12. Precision and Bias

12.1 It is not practicable to specify the precision of the procedure in this test method for measuring the gain factor of a core because there are too few laboratories capable of making this test to conduct an interlaboratory study. The procedure in

TABLE 3 Lamination Factor

	Tape Thickness		Stacking Factor	
	in.	[cm]		[m (10^{-6})]
0.0005		[0.0013]	[13]	0.5
0.0010		[0.0026]	[25]	0.75
0.002		[0.0051]	[51]	0.85
0.004		[0.010]	[100]	0.90
0.006		[0.015]	[150]	0.90
0.010 to 0.014		[0.025 to 0.36]	[250–360]	0.95

this test method for measuring the gain factor of a core has no bias because the gain factor is defined only in terms of this test method.

13. Keywords

13.1 core; coregain; gain factor; induction; magnetic amplifier; magnetic field strength

ANNEX

(Mandatory Information)

A1. STANDARD TEST SPECIMENS FOR USE IN EVALUATING CORE MATERIALS

A1.1 When the test specimen is intended for evaluation of basic materials for core construction, the test sample shall be selected as required for strip materials in accordance with the provisions of Practice A 34/A 34M. The procurement specifications should specify the method of sample selection and subsequent treatment for such cores. When not covered by specifications, the provisions and requirements of Annex A1 shall govern the sample selection and preparation.

A1.2 The test specimen, unless otherwise agreed upon between the purchaser and manufacturer, shall be a tape-wound core having the dimensions listed in Table A1.1.

A1.3 The test sample material shall be slit to the required width. This is commonly done on commercially available rotary slitting equipment. It is essential that the quality of the slitting be according to the best commercial practice with a minimum burr and free of waves and wrinkles. The slit strips shall be clean and free of any dust or foreign matter. They shall be long enough to wind the required core without welding or patching two or more pieces together.

A1.4 The surfaces of the strip must be coated with a refractory insulation before or during the winding of the core. A fine grade of magnesium oxide (less than 5 μm in diameter) has been found satisfactory. It may be made to adhere to the strip by applying a light oil film on the strip previous to or during core winding. All insulation materials and bonding agents (such as the oil) used in the insulation process must be carefully screened to eliminate those that could contaminate the cores during the heat-treating process. The oil, suggested above, should be selected so that it can be removed by heating

at a low temperature in air, such as at 150°C [302°F]. The amount of the insulation must allow the cores to meet the lamination factors of Table A1.2.

A1.5 The winding tension may be used to control the stacking factor. A satisfactory core, after heat treatment, may be telescoped with light finger pressure. The lamination factors must conform to the limits of Table A1.2.

A1.6 At one spot of the first layer and at one spot of the outer layer, the core may be spot welded to keep the core from unwinding. The welds must not penetrate more than three adjacent layers.

A1.7 When a core is to be used for basic material evaluation, the area, A , shall be determined as follows:

$$A = (m/\ell_1\delta)$$

where:

- A = metallic cross-sectional core area [cm², cnst. unit; m², SI unit],
- m = mass of the core material [g, cnst. unit; kg, SI unit],
- ℓ_1 = mean magnetic path length [cm, cnst. unit; m, SI unit], and
- δ = standard assumed density of the core material [g/cm³, cnst. unit; kg/m³, SI unit].

A1.8 The heat treatment of the standard core specimen will determine the performance of the core material to a critical degree. The choice of time and temperature and annealing atmosphere must provide the proper conditions for development of optimum properties as specified by the material

TABLE A1.1 Dimensions of Standard Tape-Wound Core Specimens to Be Used When Evaluating Basic Material Properties

NOTE 1—For other thickness of material, d , the core size shall be determined by mutual agreement and shall have the following limitations: the inside diameter shall be at least 140 d but less than 2000 d , the strip width shall be at least 30 d but not more than 500 d , the outside diameter shall be 1.25 times the inside diameter, the mean magnetic path of such a core is 3.54 times the inside diameter.

Dimension	Light Gage, in [m]	Heavy Gage, in. [m]
Strip thickness, d	0.0005 [13 μm] up to and including 0.006 [150 μm]	0.004 [100 μm] up to and including 0.014 [350 μm]
Inside diameter, D_i	1.000 [0.0254]	2.00 [0.0508]
Outside diameter, D_o	1.250 [0.0318]	2.500 [0.0636]
Strip width, w	0.0250 [0.006 36]	0.500 [0.0127]
Mean magnetic path, ℓ_1	3.54 [0.0898]	7.07 [0.1796]

TABLE A1.2 Lamination Factor Range for Standard Tape-Wound Core Specimens When Used for Evaluation of Basic Material Properties

NOTE 1—Definition of lamination factor may be found in Terminology A 340.

Strip Thickness, <i>d</i>		Lamination Factor, Range, <i>S</i> , %
in.	[m]	
0.0005 to 0.0008	[13 to 20]	50 to 60
0.0008 to 0.0015	[20 to 38]	60 to 80
0.0015 to 0.003	[38 to 76]	75 to 90
0.003 to 0.008	[76 to 200]	80 to 90
0.008 and up	[200] and up	95

manufacturer. The typical conditions for heat treatment of standard core specimens when used for material evaluation are found in **Table A1.3**.

A1.9 Furnace:

A1.9.1 The furnace should be suitable for heat treating at temperatures up to 1204°C [2200°F] in pure dry hydrogen atmospheres. Where required, its size and heating rate should be such as to meet the heating rates specified in **Table A1.3** or other agreed upon conditions capable of imparting to the charge temperatures which are uniform within 10°F [5.5°C].

A1.9.2 The temperature-controlling equipment should be selected to allow the above 5.5°C [$\pm 10^\circ\text{F}$] accuracy in setting and uniformity.

A1.9.3 When dry hydrogen atmospheres are used, the exit dew point should be below -40°C [-40°F]. (**Warning**—Hydrogen is a highly explosive gas. Extreme care must be exercised when using it.)

A1.10 Annealing Trays:

A1.10.1 The specimens are arranged in trays in as stable a way as possible to avoid deformations. At the heat-treating temperatures, the magnetic materials do not have enough strength to support themselves. If the trays are not flat, the samples will follow the contour of the trays.

A1.10.2 Adequate strength of the trays at the annealing temperature should be one of the selection criteria for tray materials.

A1.10.3 The thermal coefficient of expansion of the tray material and spacers should be preferably of the same order as that of the magnetic material to be heat treated.

A1.10.4 The chemical composition of the material used for trays and spacers should be examined and found not to have any interactions with the magnetic material. It is generally desirable that they be free from carbon and sulfur.

A1.10.5 The tray arrangement in the furnace retort and the piling of the specimens should be arranged in such a way that the heat-treating atmosphere freely reaches all specimens.

TABLE A1.3 Typical Range of Heat-Treatment Conditions for Standard Cores When Used for Material Evaluation

	80 % Nickel-Iron Alloy	50 % Nickel-Iron Alloy	Oriented Silicon-Iron	49 % Cobalt-Iron 2 % Vanadium
Temperature, °C [°F]	930 to 1200 [1700 to 2200]	930 to 1200 [1700 to 2200]	650 to 870 [1200 to 1600]	650 to 870 [1200 to 1600]
Atmosphere	hydrogen	hydrogen	up to 20 % hydrogen, balance nitrogen	hydrogen
Flow rate, in volume changes/h	10	10	10	10
Time charge is at temperature, h	2	2	2	2
Heating rate, °C [°F]/h ± 20 %	280 [500]	280 [500]	280 [500]	280 [500]
Cooling rate, °C [°F]/h ± 20 %	upon agreement with supplier	280 [500]	280 [500]	upon agreement with supplier

APPENDIXES

(Nonmandatory Information)

X1. FLUX VOLTMETER INSTRUMENTATION

X1.1 Resistance-Capacitance (R-C) Integrator-Amplifier
(See Fig. X1.1)

X1.1.1 A simple R-C network can be used as an effective integrator. With attention to detail, it can perform integration with an accuracy sufficient for flux measurements. For proper operation, the ratio of R to $1/\omega C$ should be at least 250 to 1 at the test frequency. Otherwise, a phase displacement at the lower frequencies will appear as a droop on the flat-top portion of the integrated waveform. A high-quality, low-loss capacitor and a noninductive resistor are required.

X1.1.2 The R-C network should be completely shielded to avoid stray pickup at the test frequency. This pickup can cause either a rise or droop on the flat top of the output waveform.

X1.1.3 A safe test for proper integration and a minimum of low-frequency phase displacement is to use the integrator to observe the flux-current loop on an oscilloscope under sine-current excitation conditions. The test core should be of the square-loop variety (oriented 50 % Ni-Fe) with a B_r/B_{max} ratio of 0.98 or more and driven to a peak magnetic field strength of 2 Oe [0.025 A/m]. For this check, the “tails” of the flux-current loop should show no crossover or opening. The oscilloscope should be operated direct coupled with a probe on the input to obtain very high input impedance.

X1.1.4 The input impedance of the R-C integrator must be of such value as to cause a very minimum of loading on the test-core secondary. This value of impedance should be greater than the core impedance Z (see 11.6).

X1.1.5 Since the output of an R-C integrator is usually very low, an amplifier is used to increase this level to a value sufficient for measurement purposes.

X1.1.6 The input impedance of the amplifier should be high enough to avoid unnecessary loading of the integrator. An input impedance greater than 1000 Ω at the test frequency is recommended.

X1.1.7 The amplifier should employ sufficient feedback to enable good amplitude linearity ($\pm 0.1\%$).

X1.1.8 The frequency response should be low enough to reproduce a practically perfect square wave at the lowest test

frequency with no visible droop on the flat-top portion of the waveform. The frequency of highest satisfactory response should be at least 20 times the highest test frequency to be used. A suitable amplifier would have good frequency response from 1 to 100 Hz for testing in the frequency range from 60 to 5000 Hz.

X1.1.9 A standard half-wave voltage-doubler circuit is used to enable peak detection of the integrated waveform to be performed. This circuit yields a dc voltage equivalent to the peak-to-peak (P-P) value of its input voltage. To avoid losses caused by diode leakage and barrier effects, the input voltage should be at least 200-V P-P under B_{max} conditions. A $10\times$ multiplier should be used on the amplifier to increase the $(B_{max} - B_r)$ integral of square materials (B_r/B_{max} ratios above 0.80). In this way, the doubler circuit is always sensing waveforms of the necessary amplitude.

X1.1.10 The indicating part of the flux meter is a dc voltmeter. The full-scale accuracy of this instrument should be at least $\pm 0.25\%$. This accuracy is necessary to permit an overall system accuracy of about $\pm 0.5\%$.

X1.2 Miller Integrator (See Fig. X1.2)

X1.2.1 A Miller integrator or operational amplifier connected as a Miller integrator operates on the core pickup voltage in much the same manner as the R-C integrator. Its most desirable characteristic, however, is that the value of the capacitance in the R-C network is effectively increased by the open-loop gain of the amplifier. This results in a larger time constant which is the equal to $RC(1 + A)$, where A is the gain of the amplifier.

X1.2.2 The frequency requirements for the amplifier used in this integrator are very similar to those specified for the R-C integrator system of X1.1.8.

X1.2.3 The normally high input impedance of the Miller integrator will contribute very little loading on the core secondary voltage. This impedance is defined in X1.1.4.

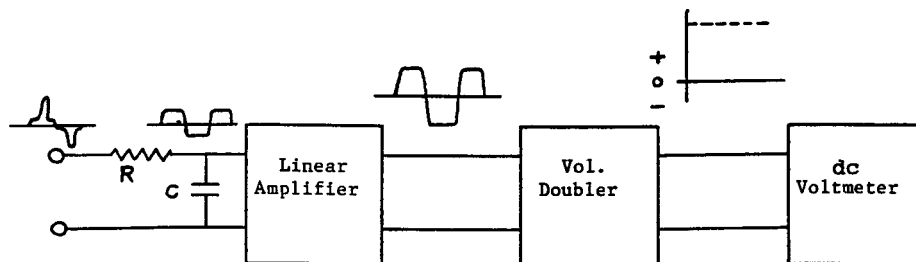

FIG. X1.1 R-C Integrator-Amplifier

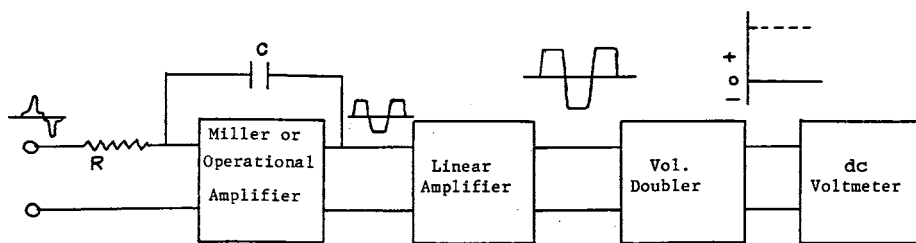

FIG. X1.2 Miller Integrator

X1.2.4 Two other desirable characteristics of this integrator are a higher output signal amplitude and the capability of adapting reasonable loading without reducing its quality of integration.

X1.2.5 Since the integrator output is still too low for good peak detection, an additional amplifier is required.

X1.2.6 The requirements pertaining to linearity and frequency response of this amplifier are the same as those called for in X1.1.8.

X1.2.7 The input impedance need not be abnormally high since integrator loading is not very critical.

X1.2.8 The half-wave voltage doubler and dc voltmeter used with this system should have characteristics and accuracies identical with those established in the preceding system X1.2.1 and X1.2.2.

X1.3 Rectifier-Integrator (See Fig. X1.3)

X1.3.1 In this system, an amplifier is used to increase the core output voltage to a level sufficient for accurate full-wave rectification. The frequency requirements here are more stringent for this amplifier than those of the foregoing systems. This is due to the magnitude and number of harmonics in the core output voltage. The high-frequency response must be adequate to handle the higher-order harmonics properly, which, in some cases, may be in excess of 50 times the test frequency. A suitable amplifier would have good frequency response from 5 to 250 kHz for testing in the frequency range from 60 to 5000 Hz.

X1.3.2 Linearity should be at least $\pm 0.1\%$.

X1.3.3 The amplifier output should be capable of handling 200 V, peak, without clipping.

X1.3.4 A full-wave diode bridge is used to rectify the amplifier output voltage. The large voltage swing tends to minimize the errors caused by nonlinearities in the diode voltage-current characteristics at the low-voltage levels. These areas contain a large portion of the average value of the overall waveform. Consequently, it is necessary to amplify the core output voltage until the low-level regions fall on the linear portion of the diode characteristic.

X1.3.5 The use of germanium diodes further will reduce the error caused by the barrier voltage encountered in solid state diodes.

X1.3.6 Linearity can be further enhanced by using diodes to shunt the rectifier bridge. These diodes should have the same characteristics, be held at the same temperature, and carry the same current levels as bridge diodes.

X1.3.7 The indicating instrument must be of the d'Arsonval type. The actual integration is performed by this instrument which responds to the average value of the rectified waveform.

X1.3.8 The full-scale accuracy of this instrument should be $\pm 0.25\%$.

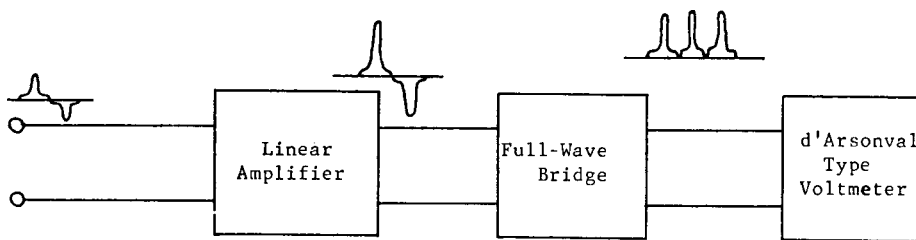

FIG. X1.3 Rectifier-Integrator

X2. CALIBRATION CIRCUIT FOR THE FLUX VOLTmeter

X2.1 This calibration circuit develops an ac test voltage having a waveform similar to the induced voltage in winding N_4 of Fig. 1 during the measurement of B_{max} . The circuit, as shown in Fig. X2.1, uses a tape-wound core of square hysteresis loop material, T_3 , which is excited by a sinusoidal current limited by resistor R_2 . The induced voltage is rectified in the silicon diodes in a bridge rectifier circuit.

X2.2 Because the same current flows in the ac calibration resistor as flows in the dc milliammeter, the average value of the current indicated by the milliammeter, A_4 , is the same as that flowing in the ac shunt resistor, R_4

$$E_{cal} = I_{ac}R_4$$

X2.3 The voltage developed across R_4 may be related to

E_{avg} , the average of the induced voltage in N_4 of Fig. 1 as follows:

$$E_{avg} = 2(\Delta B) N_4 f A \times 10^{-8} \text{ cnst. unit}$$

$$E_{avg} = 2\Delta B N_4 f A \text{ SI unit}$$

where:

- ΔB = change in magnetic induction, G [T];
- N_4 = number of turns linking the core specimen which is connected to the flux voltmeter (see Fig. 1);
- f = frequency, Hz; and
- A = cross-sectional area of magnetic flux path of the specimen core, cm^2 [m^2].

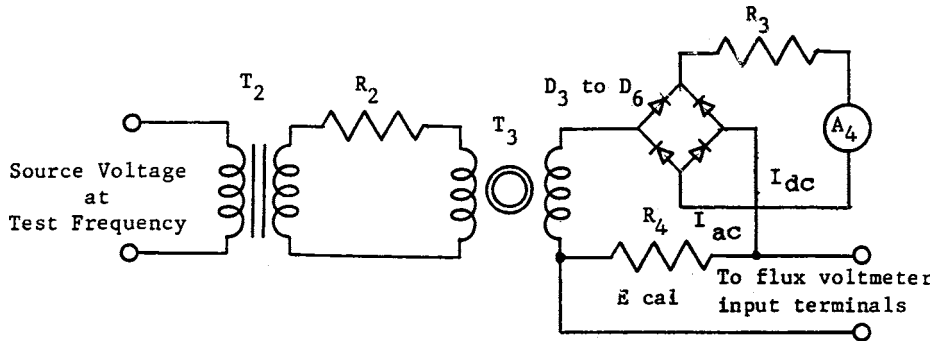

NOTE 1—

- T_2 —stepdown transformer, output 25 V at 1.0 A
- R_2 —voltage-dropping resistor, 25 Ω , 25 W
- T_3 —square hysteresis loop core—primary 20 turns (approximately), secondary five turns when core area = 1 cm^2
- D_3 to D_6 —full-wave rectifier, silicon diodes
- R_3 —current control resistor, 50 to 100 Ω
- A_4 —milliammeter 0.25 % accuracy, 1 to 100 mA depending on frequency
- R_4 —ac current shunt, 1.0 to 10 Ω

FIG. X2.1 Calibration Circuit for Flux Voltmeter

X3. GRAPHICAL REPRESENTATION OF THE MAGNETIC AMPLIFIER CORE TEST (C.C.F.R.)

X3.1 The figures of this Appendix show in graphical form the various steps and interpretation of the (C.C.F.R.) magnetic amplifier core test.

X3.2 Fig. X3.1 and Fig. X3.2 are to be used for the determination of induction, B_{max} , reached in the core material when magnetized by full-wave sinusoidal current to the specified value of H_{max} Oe, using procedures of 10.2.

X3.3 Fig. X3.3 and Fig. X3.4 are for use in the determination of the residual induction, B , in the core material after being magnetized to H_{max} Oe and the value of $B_{max} - B$ using the procedures of 10.3.

X3.4 Reference should be made to Fig. X3.5 and Fig. X3.6 for determination of the direct current biasing field, H_1 , required to reset the core flux sufficiently to establish an induction change of ΔB , in the core material when using the procedures of 10.4.

X3.5 Fig. X3.7 and Fig. X3.8 are useful for determination of the direct current biasing field, H_2 , required to reset the core flux sufficiently to establish an induction change of ΔB_2 in the core material when using the procedures of 10.5.

X3.6 Graphical representation of the combined flux-current loops which represent the various test conditions of Section 10 is shown in Fig. X3.9.

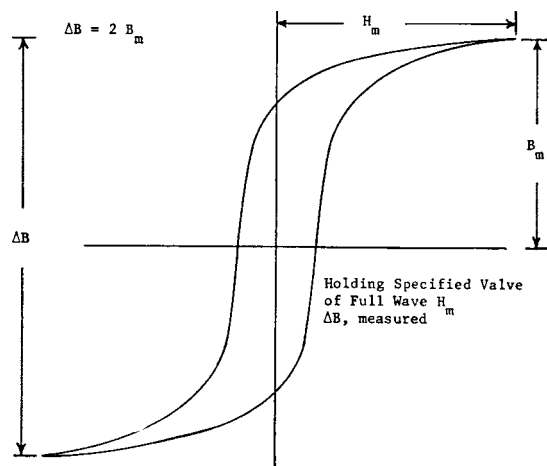

FIG. X3.2 Sine-Current SCM Flux-Current Loop for Test Described in 10.2

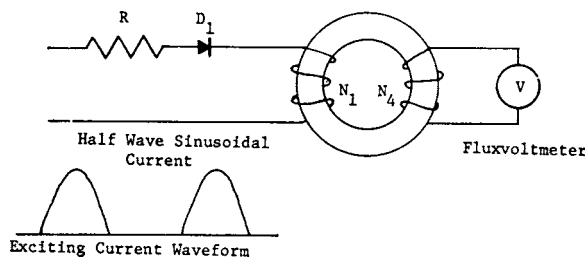

FIG. X3.3 Circuit Diagram for Tests Described in 10.3

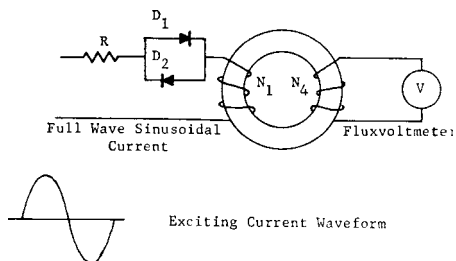

FIG. X3.1 Circuit Diagram for Tests Described in 10.2

X3.7 A characteristic performance curve (Fig. X3.10), which represents a full range of operating values for a magnetic amplifier core, may be obtained by plotting the induction changes versus a number of different values of the dc biasing magnetic field strength. The procedures of 10.4 and 10.5 are followed except that a number of different values of the dc biasing field are established for determination of the corresponding values of induction change ΔB .

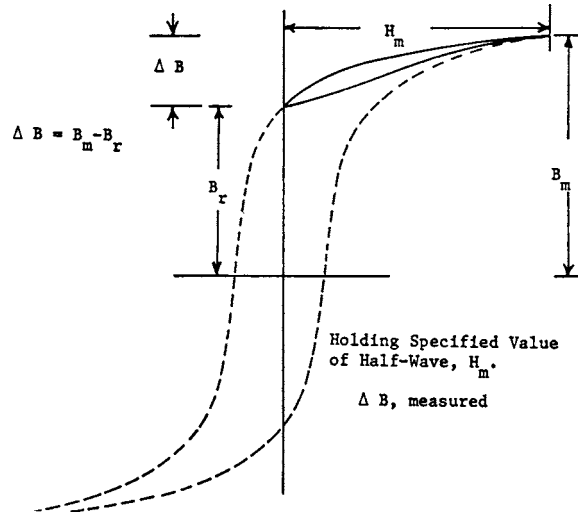

FIG. X3.4 Sine-Current CM Flux-Current Loop for the Test Described in 10.3

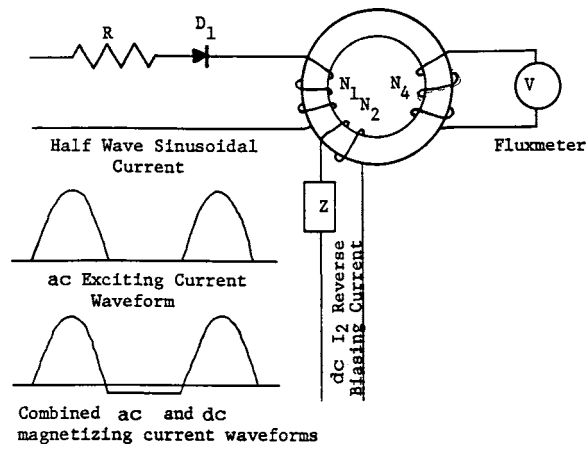

FIG. X3.5 Circuit Diagram for Tests Described in 10.4

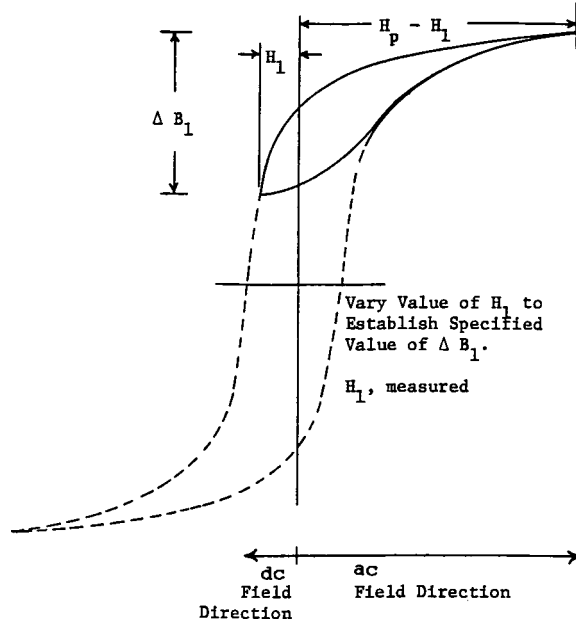

FIG. X3.6 Flux-Current Loop with Combined dc Biasing Field, H_1 , and Half-Wave Sine-Current Field, H_p , as Used for Tests Described in 10.4

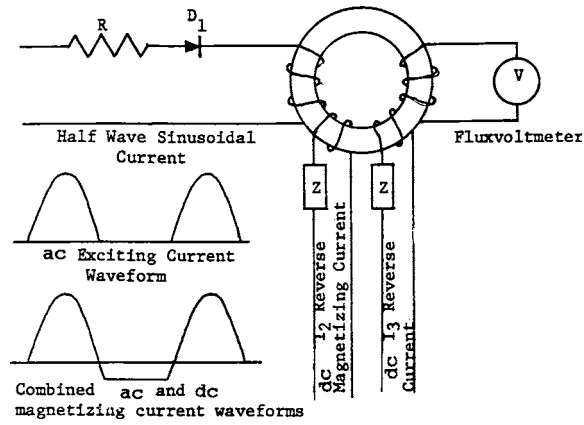

FIG. X3.7 Circuit Diagram for Tests Described in 10.5

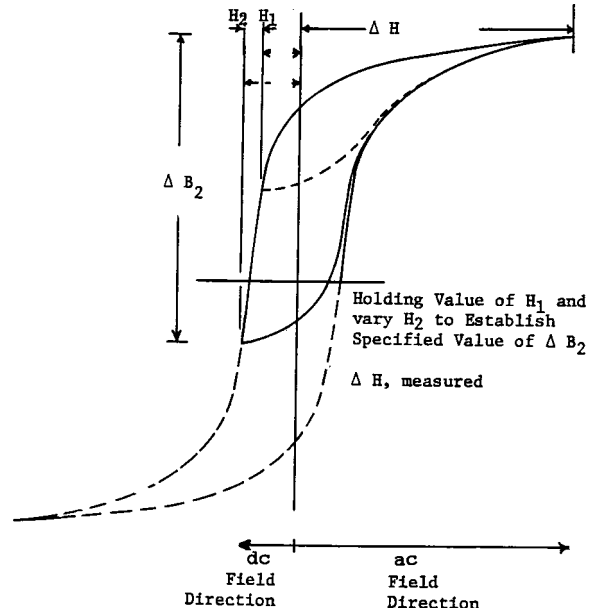

FIG. X3.8 Flux-Current Loop with Combined dc Biasing Fields, H_1 , H_2 , and Half-Wave Sine-Current Field, H_p , as Used for Tests Described in 10.5

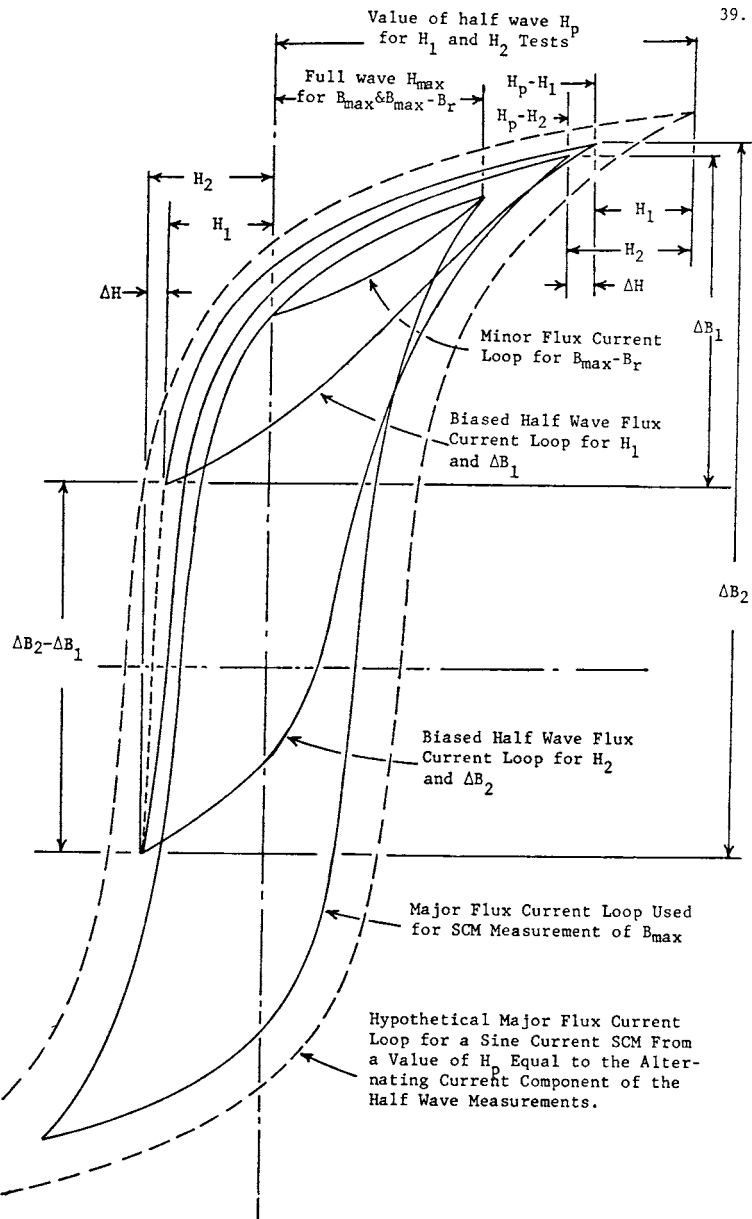

FIG. X3.9 Composite Flux-Current Loops Showing Relationship of Various Test Conditions of the C.C.F.R. Test

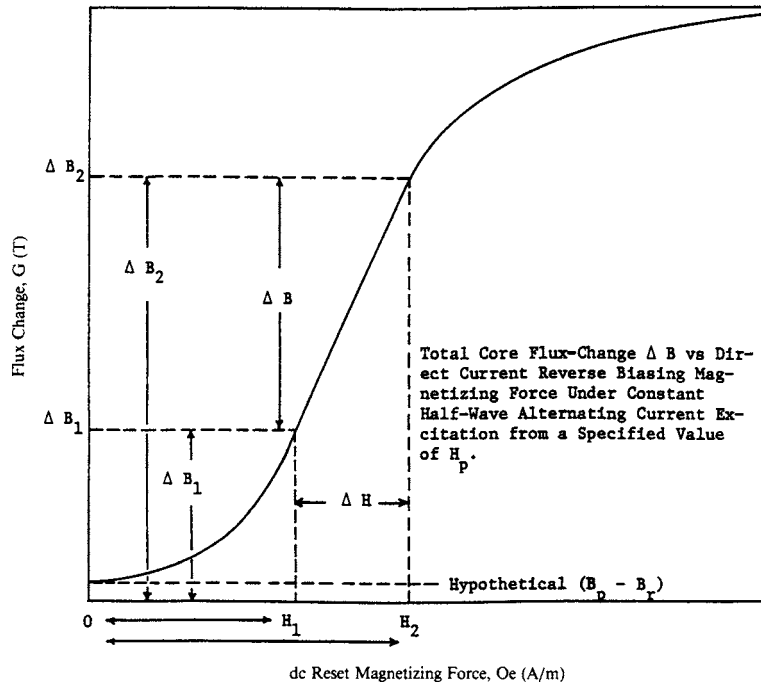

FIG. X3.10 Characteristic Curve of Core Specimen Under Half-Wave ac Excitation and dc Reset Conditions

ASTM International takes no position respecting the validity of any patent rights asserted in connection with any item mentioned in this standard. Users of this standard are expressly advised that determination of the validity of any such patent rights, and the risk of infringement of such rights, are entirely their own responsibility.

This standard is subject to revision at any time by the responsible technical committee and must be reviewed every five years and if not revised, either reapproved or withdrawn. Your comments are invited either for revision of this standard or for additional standards and should be addressed to ASTM International Headquarters. Your comments will receive careful consideration at a meeting of the responsible technical committee, which you may attend. If you feel that your comments have not received a fair hearing you should make your views known to the ASTM Committee on Standards, at the address shown below.

This standard is copyrighted by ASTM International, 100 Barr Harbor Drive, PO Box C700, West Conshohocken, PA 19428-2959, United States. Individual reprints (single or multiple copies) of this standard may be obtained by contacting ASTM at the above address or at 610-832-9585 (phone), 610-832-9555 (fax), or service@astm.org (e-mail); or through the ASTM website (www.astm.org).