

Review of Active and Reactive Power Sharing Strategies in Hierarchical Controlled Microgrids

Yang Han, *Member, IEEE*, Hong Li, Pan Shen, Ernane A.A. Coelho and Josep M. Guerrero, *Fellow, IEEE*

Abstract—Microgrids consist of multiple parallel-connected distributed generation (DG) units with coordinated control strategies, which are able to operate in both grid-connected and islanded mode. Microgrids are attracting more and more attention since they can alleviate the stress of main transmission systems, reduce feeder losses, and improve system power quality. When the islanded microgrids are concerned, it is important to maintain system stability and achieve load power sharing among the multiple parallel-connected DG units. However, the poor active and reactive power sharing problems due to the influence of impedance mismatch of the DG feeders and the different ratings of the DG units are inevitable when the conventional droop control scheme is adopted. Therefore, the adaptive/improved droop control, network-based control methods and cost-based droop schemes are compared and summarized in this paper for active power sharing. Moreover, nonlinear and unbalanced loads could further affect the reactive power sharing when regulating the active power, and it is difficult to share the reactive power accurately only by using the enhanced virtual impedance method. Therefore, the hierarchical control strategies are utilized as supplements of the conventional droop controls and virtual impedance methods. The improved hierarchical control approaches such as the algorithms based on graph theory, multi-agent system, the gain scheduling method and predictive control have been proposed to achieve proper reactive power sharing for islanded microgrids and eliminate the effect of the communication delays on hierarchical control. Finally, the future research trends on islanded microgrids are also discussed in this paper.

Index Terms—Active power sharing, reactive power sharing, microgrids, graph theory, consensus control, hierarchical control, droop control, nonlinear and unbalanced loads, communication delay.

NOMENCLATURE

Abbreviations

CC	Central control
CVS	Controllable voltage source
CCM	Current control mode
CCVSI	Current controlled voltage source inverters

Manuscript received Feb 02, 2016; revised April 10, 2016; accepted May 12, 2016. Date of current version *****; date of current version *****. This work was supported in part by the National Natural Science Foundation of China under Grant 51307015, and in part by the State Key Laboratory of Power Transmission Equipment & System Security and New Technology under Grant 2007DA10512713405, and in part by the Open Research Subject of Sichuan Province Key Laboratory of Power Electronics Energy-Saving Technologies & Equipment under Grant szjj2015-067, and in part by the Open Research Subject of Artificial Intelligence Key Laboratory of Sichuan Province under Grant 2015RZJ02, and in part by the Fundamental Research Funds of Central Universities of China under Grant ZYGX2015J087. Paper no. TPEL-Reg-2016-02-0220.

Y. Han, H. Li and P. Shen are with the Department of Power Electronics, School of Mechatronics Engineering, University of Electronic Science and Technology of China, No.2006, Xiyuan Avenue, West Hi-Tech Zone, Chengdu 611731, China (e-mail: hanyang@uestc.edu.cn; Li_Hong01@126.com; panshen01@126.com).

Ernane A.A. Coelho is with the Universidade Federal de Uberlandia, Uberlandia 38400-902, Brazil (ernane@ufu.br).

J. M. Guerrero is with Department of Energy Technology, Aalborg University, 9220 Aalborg, Denmark (e-mail: joz@et.aau.dk).

Color versions of one or more of the figures in this paper are available online at <http://ieeexplore.ieee.org>.

Digital Object Identifier *****/TPEL.*****

DG	Distributed generation
EMS	Energy management system
LBC	Low bandwidth communication
MAS	Multi-agent system
MG	Microgrid
MGCC	Microgrid central controller
MPPT	Maximum power point tracking
PCC	Point of common coupling
PI	Proportional integral
PLL	Phase-locked loop
PR	Proportional resonant
PRPS	Proportional reactive power sharing
PV	Photovoltaic
RES	Renewable energy source
SP	Smith predictor
VCM	Voltage control mode
VSG	Virtual synchronous generator

Variables

E	Output voltage amplitude of the microgrid
E_i	Output voltage amplitude of the i^{th} DG
P_i	Measured averaged active power through a low-pass filter
Q_i	Measured averaged reactive power through a low-pass filter
V_{MG}	Voltage amplitude of the microgrid
Δf	Frequency deviation
ΔP	Active power deviation
ΔQ	Reactive power deviation
ΔV	Voltage deviation
m_i	Active droop coefficient in P - f droop control
n_i	Reactive droop coefficient in Q - V droop control
m_Q	Reactive droop coefficient in Q - f droop control
n_P	Active droop coefficient in P - V droop control
ω_i	Output angular frequency of the i^{th} DG
f_{MG}	Frequency of the microgrid
$\beta_{i\omega}$	Changeable integral gain scheduler
β_{poi}	Changeable proportional gain scheduler
β_i, k_i	Gain coefficients

Parameters

E^*	Nominal values of the DG output voltage amplitude
ω_i^*	Nominal values of the DG angular frequency
f_{ref}	Frequency reference
P_{max}	Maximum value of the active power
Q_{max}	Maximum value of reactive power
R_v	Resistive virtual impedance
S_N	Nominal apparent power
T	Sampling time
V_{ref}	Voltage reference
V_{min}	Minimum value of voltage amplitude

I. INTRODUCTION

WITH the increased penetration of distributed generation (DG) units on the electrical grid systems, the renewable energy sources (RESs) including micro-turbines, fuel cells, photovoltaic (PV) systems and wind energy systems have been widely used in the distributed power systems in the past decades [1], [2]. The DG units play an important role in reducing pollution, decreasing power transmission losses and improving local utilization of RESs, which becomes a strong support for the large-scale power grid [3]. However, DG units may also bring challenges to the distribution network such as inverse power flow, voltage deviations and voltage fluctuations. When a number of DG units are clustered together, they can form a microgrid (MG) that solves the problems caused by high penetration of DG units successfully and makes the large-scale application of DG systems possible [4].

Fig. 1 shows the basic architecture of an AC MG system. The PV systems and energy storage systems (ESSs) are connected to the AC bus through the DC/DC/AC converters and wind turbines are tied to the AC bus through the AC/DC/AC converters. In the case of islanding operation, RESs mainly provide AC power to the loads through the local control. In the grid-connected mode, the AC MG is connected to the upstream grid through a tie line at the point of common coupling (PCC) and there is power flow between MG system and the grid [5-9].

In order to ensure stability and economical operation of MG, the active and reactive powers of the DG units should be shared simultaneously. The droop controls are the well-developed control methods without communication lines and can be used to achieve the power sharing by imitating steady state characteristics of the synchronous generator (SG) in islanded MGs [10-13]. A new control method called virtual synchronous generator (VSG) has been proposed to mimic the steady-state and transient characteristics by using the swing equation. Although the inertia of the DG units can be enhanced compared to the droop control, the output active power of VSG is oscillatory and dynamic power sharing among the DG units would be sluggish due to the virtual inertia, especially

under weak microgrid conditions [14-20]. Therefore, the utilization of the improved droop control method is still popular to share the active and reactive powers among the DG units in islanded MGs [21-25].

To ensure the state optimization of a complex MG, the accuracy and dynamic stability of active power sharing should be considered. A static droop compensator is utilized for active power sharing in [26]. An enhanced droop control featuring a transient droop performance is proposed in [27]. To improve the active and reactive power decoupling performance, improved droop controllers with virtual output impedance are reported [28]. However, the low-frequency dynamics of the inverter due to the time-scale separation between the power, voltage, and current dynamics are not improved in [24-28]. Therefore, an optimized droop control is presented in [29] to improve the dynamic stability of the active power sharing and an adaptive decentralized droop-based power sharing control scheme is presented in [30] to adjust the dynamic performance of the power sharing without affecting the static droop gain. Moreover, in order to share active power under complex load conditions, an algorithm-based active power regulation strategy is proposed in [31], and a hierarchical active power management strategy is presented in [32]. Although the active power sharing is achieved and the dynamic response of the microgrid is ensured, the complex feeder impedance and generation cost of the microgrid are not considered. In [33], a high disturbance rejection performance against voltage disturbances is achieved when sharing the active power and some improved P - V and Q - f droop control methods are presented in [34] to share the active power under resistive/unknown feeder impedance conditions. As an economic problem is introduced in hierarchical control, the criterion for active power should be based on generation cost of the microgrid instead of a simple proportional or equivalent relation based on the generator ratings. A nonlinear cost-based scheme which is proposed in [35] and a linear cost-prioritized droop scheme presented in [36] both can optimize active power sharing and simultaneously minimize the total cost of generation.

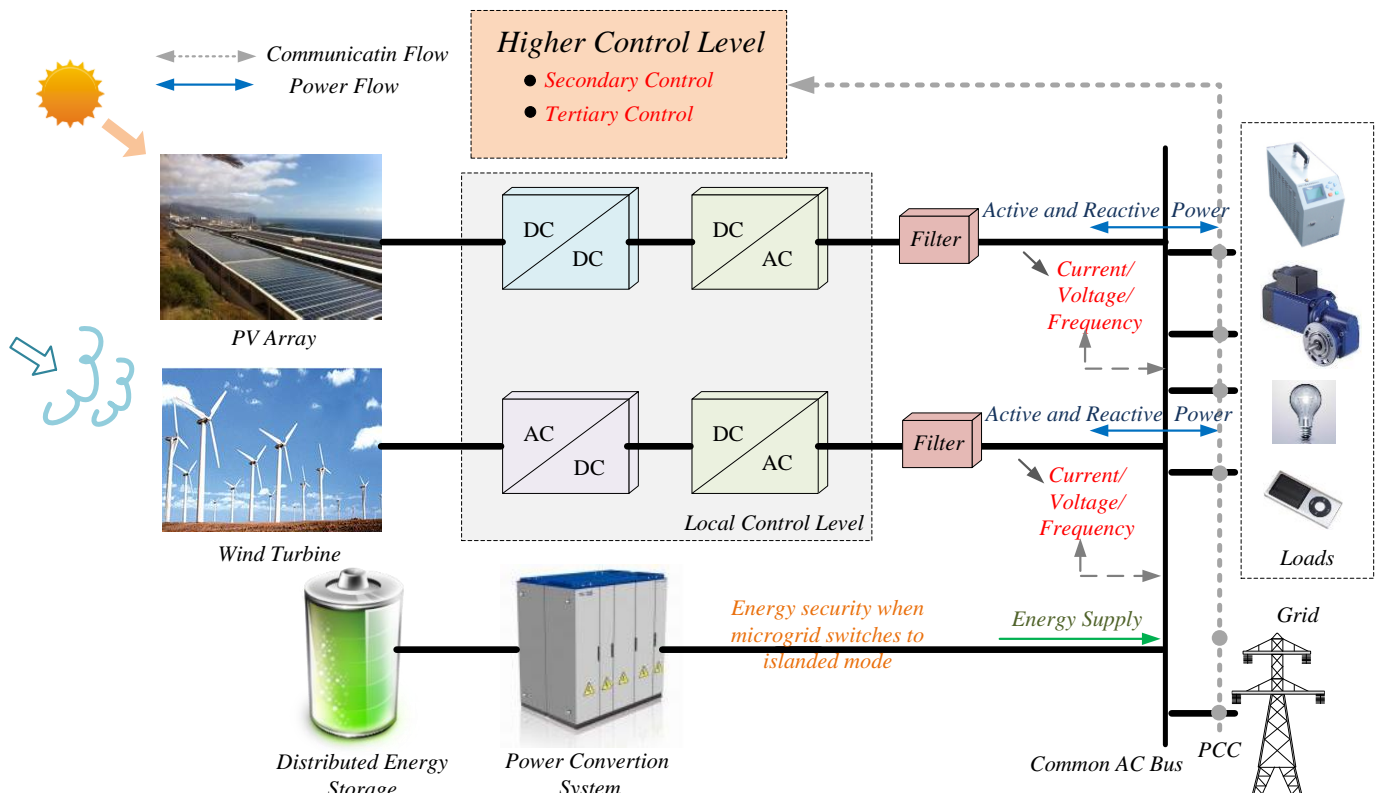

Fig. 1. Architecture of the AC microgrid [5].

When all DG units operate at the same frequency in the steady-state conditions, the active power can be regulated well in improved droop control schemes, but reactive power sharing is still poor and harmonic power will appear in DG units under unequal feeder impedance and nonlinear load conditions [37]. Under extreme situations, the poor reactive power sharing may result in severe circulating reactive powers among the DG units and may cause system instability [38]. To share the reactive power, various droop control methods have been proposed, which include three main categories: the improved primary droop control methods [18], [20], [39-41], [70], [71], the improved virtual impedance methods [42-52] and the improved hierarchical control strategies [63-66], [72]-[79].

An adaptive voltage droop control is presented in [39] to share the reactive power. The effect of the mismatched feeder impedance is compensated by the adaptive droop coefficients and a reactive power sharing can be shared. The method is immune to the communication delay, but the nonlinear and unbalanced loads are not considered. An enhanced control strategy is presented in [40] to share the reactive power accurately, where the active power disturbance is adopted to identify the error of reactive power sharing and it is eliminated by using a slow integral term. Unfortunately, the signal injection method deteriorates the power quality and affects the system stability. To regulate the unbalance power and the reactive power, an adaptive inverse control with the improved droop control algorithm is proposed to adjust the weight coefficients of digital filters in real time [41]. However, the reactive power sharing of islanded MG might be poor under unbalanced and nonlinear load conditions.

It is difficult to share the reactive power accurately under the mismatched feeder impedance, and nonlinear and unbalanced load conditions by the improved droop control. As a supplement of the improved droop control, the methods based on the virtual impedance or improved virtual impedance, have been proposed to share the active and reactive powers [42-49]. Although the inductive virtual impedance can enhance the capacity of the reactive power sharing under the mismatched feeder impedance condition, the reactive power cannot be shared accurately when the loads are nonlinear and unbalanced in islanded MGs. The energy management system (EMS) is utilized in [50] to allocate the reactive power to DG units according to their own capacities, the total demand of loads and the adaptive coefficients, but the adaptive coefficients are difficult to be obtained. In [51], an enhanced virtual impedance control strategy has been proposed to share the reactive power in the islanded MG with the mismatched feeder impedance, where virtual impedances are used at the fundamental and harmonic frequencies. However, a poor reactive power sharing may occur in a three-phase converter with nonlinear loads. In [52], the control strategy based on virtual resistance is presented to share the reactive power under mismatched feeder impedance, and nonlinear and unbalanced load conditions. However, if the feeder or load is disconnected, the MG system would be unstable, which limits its practical applications.

Since it is hard to achieve the reactive power sharing by improved virtual impedance methods in complex MG systems, the hierarchical control strategy has been proposed to guarantee the steady-state and dynamic performance of the current sharing. Moreover, the redundancy of MGs is improved, and the microgrid frequency and voltage amplitude can be restored to the rated values while sharing the active and reactive powers. Specifically, the hierarchical control structure of MGs is divided into three layers as indicated in Fig. 1 [53], [54].

1) Primary Level: The primary control focuses on the stability of

voltage and frequency. The droop control is applied in this level to achieve the active and reactive power sharing without using communication channels.

2) Secondary Level: The secondary control performs the function to eliminate the frequency and voltage deviations caused by the droop control, which includes power flow control of the interconnection lines.

3) Tertiary Level: The tertiary control deals with economic dispatching, operation scheduling, and power flow between the MG and grid by regulating the voltage and frequency of the grid-connected MG, and adjusting the power generation in real time. The energy storage and energy management systems are also required for the MG to ensure a smooth transition between islanded and grid-connected modes [55], [56].

To realize a smooth transition between grid-connected and islanded mode, some literatures avoid the tertiary control in their control strategies [57-62]. A flexible control method for islanded/grid-connected MGs with enhanced stability is presented in [60], where only local information is used in controllers to yield better reliability of the MG and make the system stable over a wide range of operation conditions with minimum transients. Considering the case of the unplanned islanded microgrid, a multi-master control method with secondary frequency control is presented in [61] to modify the local generation profile of the MG to reduce the imbalance between local load and power generation, and reduce the disconnection transients [62]. However, the hierarchical control strategies are often used to realize the seamless mode transfer in complex microgrid, and the detail of such control methods are out of this paper since this paper mainly focuses on the active and reactive power sharing in islanded microgrid.

To share the reactive power by the adaptive droop control and restore voltage amplitude and frequency to the rated value by the secondary control, a self-adjusting strategy based on hierarchical control is presented [63]. Moreover, a control method which combines the microgrid central controller (MGCC) and droop control is presented in [64] to share the reactive power. The MGCC is utilized to calculate the averaged reactive power and regulate reactive power references to the corresponding DG units. Actually, the physical modes of the MG are complex and the reactive power can be seriously affected by the communication delay. To share the active and reactive powers, the distributed strategy which integrates the current control mode (CCM) and voltage control mode (VCM) units is presented in [65]. The droop and reverse droop control are added to the CCM and VCM controllers to regulate the reactive power adaptively. Moreover, the dynamic control method is presented in [66] to ensure the reactive power sharing and prevent the voltage swells/collapse ahead of time.

Most of the existing works discuss the control and power management for islanded MGs while the power sharing problems with the mismatched feeder impedance and nonlinear loads are seldom fully considered [67-69]. In [70], the positive-sequence power is used to generate the voltage reference and the negative-sequence reactive power is used for the voltage unbalance compensation, which realizes the load power sharing. An enhanced power sharing method is proposed in [71] to share the reactive power of the islanded MG, where the frequency droop is utilized to compensate reactive, unbalance and harmonic power sharing errors. With the interactions between the frequency droop control and the variable virtual impedance in the MG, the unknown feeder impedances can be compensated and an accurate reactive power sharing is achieved in the steady state. With the further research on MGs, the mismatch of the DG feeder impedance and nonlinear and unbalanced loads supplied by MGs and communication delay in the

TABLE I.

Advantages and Disadvantages of the Different Control Strategies for the Reactive Power Sharing of Islanded Microgrid

Control strategies for the reactive power sharing	Major technologies	Advantages	Disadvantages
Improved primary droop control	Optimized droop equations [18], [20], [39-41], [70], [71]	<ul style="list-style-type: none"> •No communication line •High reliability •High redundancy 	<ul style="list-style-type: none"> •Need complex algorithms •Not suitable for complex loads •Not suitable for complex MG
Improved virtual impedance method	Adaptive/Enhanced virtual impedance [42-52].	<ul style="list-style-type: none"> •Good performance for the reactive power sharing •Suitable for nonlinear and unbalanced loads 	<ul style="list-style-type: none"> •The adaptive coefficient is difficult to be obtained •It is not easy to design a high efficiency algorithm
Improved hierarchical control	Optimized secondary control [63-66], [75]. Algorithm based on graph theory [72-74]. Multi-agent systems [76]	<ul style="list-style-type: none"> •No high bandwidth requirement •Restore the voltage and frequency to rated values •Simplify complex model of MGs •Share the reactive power with mismatch feeder impedance 	<ul style="list-style-type: none"> •Communication delay is in low bandwidth lines •Poor reactive power sharing under nonlinear/ unbalanced load conditions •The algorithms are complex

low bandwidth communication (LBC) lines show that the control strategies for the accurate reactive power sharing still need improvement. Recently, it is popular to imitate the physical structure of MGs by the graph theory and then optimize the control strategies using the algebraic algorithms [72]. An optimized algorithm based on graph theory is presented in [73] to achieve the reactive power sharing under the mismatched feeder impedance condition. In [74], the programming algorithm is presented to ensure the safety of the equipment and achieve a precise reactive power sharing simultaneously. The stochastic reactive power management strategy is presented in [75] and the uncertain active power injections are utilized to obtain an online control method for the reactive power. Note that this strategy is fully distributed and only the data of active power injection are required. Considering that the uncontrollable RES is sensitive to the outside environment, an agent-based method is presented in [76] to stabilize the active and reactive powers.

The advantages and disadvantages of different control strategies for the reactive power sharing are summarized in Table I.

Since the communication delay always exists in hierarchical control, the output correction signals sent to primary control need a time delay owing to the communication lines, which will cause damage to microgrid systems. To achieve a better active and reactive power sharing, the communication delay caused by the low bandwidth communication lines need to be considered. A gain scheduler method in [77] is utilized to adjust the reference signal from the secondary control and decrease the influence on low bandwidth communication delay. In [78], this influence is minimized by using the predictive control scheme as well. Moreover, a cooperative distributed secondary/primary control paradigm is used to realize the reactive power sharing by considering the communication delay for the MG [79].

The rest of the paper is organized as follows: Section II analyzes the shortcomings of the conventional droop control scheme for active power sharing, and summarizes the various active power sharing strategies considering the effects caused by feeder impedance, generation cost of MG. In addition, the drawbacks of the conventional secondary control methods and the necessities for sharing the reactive power are analyzed in Section III, and conventional hierarchical reactive power sharing strategies in islanded MGs are presented. Section IV presents the various methods for reactive power sharing under the mismatched feeder impedance and changeable environmental conditions, which includes the algorithms based on graph theory, programming and multi-agent systems. Besides, methods for reactive power sharing under the mismatched feeder impedance, nonlinear and unbalanced load conditions are reviewed in Section V. Section VI presents

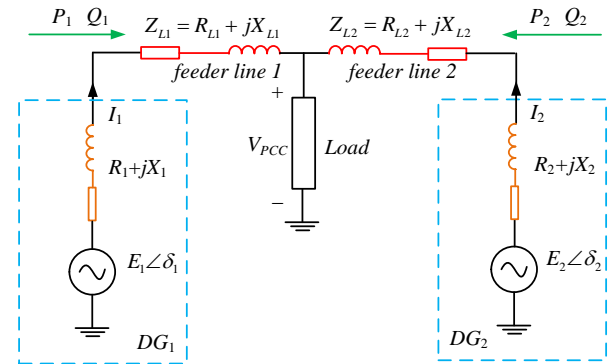

Fig. 2. The equivalent schematic of two parallel-DGs in an islanded microgrid [50].

predictive control and cooperative distributed control to decrease the effect of LBC delay. The future trends of MGs are summarized in Section VII. Finally, this paper is concluded in Section VIII.

II. CONTROL STRATEGIES FOR ACTIVE POWER SHARING PROBLEM

It is important to improve the stability of DG units and achieve the load power sharing in islanded MGs. The active power is usually considered to be shared in a decentralized manner when the droop coefficient is adopted reasonably. However, there are still some shortcomings for active power sharing in the conventional droop control strategies [80-85].

A. Problems of the Active Power Sharing in the Droop Control

Generally, for a large/medium system, the impedance is approximately inductive and the power-frequency (P - f) and reactive power-voltage (Q - V) droop control are always used [11-13]. The P - f and Q - V droop control can be determined as [11-13], [18], [42]:

$$\omega_i = \omega_i^* - m_i P_i, \quad E_i = E_i^* - n_i Q_i \quad (1)$$

where i is index representing each converter, ω_i^* and E_i^* are rated angular frequency and voltage amplitude of converter i , respectively. P_i and Q_i are measured average active and reactive power values through a low-pass filter, respectively. m_i and n_i are active and reactive droop coefficients, respectively. The equivalent circuit of two parallel-DG units is shown in Fig. 2. Z_{L1} and Z_{L2} are feeder impedance of line 1 and line 2, respectively. X (X_1 , X_{L1} , X_2 and X_{L2}) and R (R_1 , R_{L1} , R_2 and R_{L2}) are the reactance and resistance values of feeder impedance, respectively. $E_i \angle \delta_i$ represents the voltage of DG_i , and δ_i is the phase angle difference between E_i and V_{PCC} (i represents the i^{th} DG).

The output active power and reactive power for DG_i can be obtained as [18], [42], [80], [81], [86]:

$$P_i = \frac{(X_i + X_{Li})(E_i V_{PCC} \cos \delta_i - V_{PCC}^2) + (R_i + R_{Li})E_i V_{PCC} \sin \delta_i}{(X_i + X_{Li})^2 + (R_i + R_{Li})^2}. \quad (2)$$

$$Q_i = \frac{(X_i + X_{Li})(E_i V_{PCC} \cos \delta_i - V_{PCC}^2) - (R_i + R_{Li})E_i V_{PCC} \sin \delta_i}{(X_i + X_{Li})^2 + (R_i + R_{Li})^2}. \quad (3)$$

In addition, the power angle δ_i is small and it can be assumed that $\sin \delta_i \approx \delta_i$, $\cos \delta_i \approx 1$. Moreover, when the reactance is much larger than the resistance of the feeder impedance, (2) and (3) can be simplified:

$$P_i = \frac{E_i V_{PCC} \delta_i}{(X_i + X_{Li})}, \quad Q_i = \frac{V_{PCC}(E_i - V_{PCC})}{(X_i + X_{Li})}. \quad (4)$$

When the feeder impedance is approximately inductive (resistance is negligible), the active power can be shared when the droop coefficient is adopted reasonably, but some shortcomings for active power sharing are inevitable in the conventional droop control [53-56], [80-85], [101-103].

1) For the limited range of frequency deviations, the droop coefficient has to be small, which violets sharing active power. Although a larger droop coefficient can improve active power sharing performance, it would result in a higher voltage deviation from the nominal values [33-36].

2) Only the equivalent active power sharing can be guaranteed in the conventional droop control under inductive feeder impedance scenario. However, active power sharing accuracy may be compromised, and active and reactive power coupling may exist in the resistive networks. Besides, the proportional active power sharing cannot be achieved [101-103].

3) As different types of DG may exist, the conventional droop control cannot reduce the generation cost for the considered MG. Furthermore, the transition between a grid-connected and an islanded microgrid mode yields a large-signal disturbance and the dynamic stability of the active power sharing is affected [35], [36].

Therefore, the droop control for active power sharing should be further improved to get an accurate and robust active power sharing for MGs, and the details and characteristic of various control methods will be discussed herein.

B. Equivalent Active Power Sharing under Inductive Feeder Impedance Condition

In order to get high disturbance rejection performance of the active power sharing controllers against voltage disturbances and eliminate voltage and frequency deviations, an adaptive droop control is presented in [33] with the following droop functions:

$$\omega_i = \omega_i^* - m_i P_i - \hat{m}_d \frac{dP_i}{dt}, \quad E_i = E_i^* - n_i Q_i - \hat{n}_d \frac{dQ_i}{dt} \quad (5)$$

where \hat{m}_d and \hat{n}_d are adaptive gains. In this adaptive droop control, the dynamic performance of the active power sharing can be adjusted without affecting the steady-state regulation requirements.

The adaptive droop control shown in (5) can enhance the reliability of microgrids, but the dynamic stability of the active power sharing under different microgrid operating conditions are not considered. An optimized active power sharing strategy based on performance function is presented in [29] to improve the dynamic stability of active power sharing under different microgrid topologies. A quadratic performance index J is considered to find the optimum transient droop parameters m_d and maximize the microgrid stability under different operating conditions with the following expression:

$$J = \sum_{i=1}^n \sum_{k=1}^l [kTE_{oi}(k)]^2 \quad (6)$$

where $E_{oi}(k)$ represents the frequency error at the time k for DG_i , T is the sampling time, l is the total number of samples, and n is the

total number of DG units in an islanded microgrid. In (6), the frequency error is weighted by the respective time k , which ensures optimized gain tuning under different operating conditions. Combining the particle-swarm optimization technique in [87], the robust and flexible microgrid operation with seamless transfer in the transition mode can be obtained with optimized dynamic power sharing performance.

C. Improved P-V/Q-f Droop Control under Resistive Feeder Impedance Condition

The active power sharing accuracy may be compromised by the conventional P - f and Q - V droop control under resistive networks. Before using the conventional P - f and Q - V droop schemes with resistive networks, the decoupling techniques such as performing linear transformation and inserting virtual impedance are presented to solve this problem [88-90]. Moreover, P - V and Q - f droop control strategies are often used to achieve equivalent active power sharing under resistive feeder impedance condition [91], [92], and the transfer function of droop equations are denoted as:

$$\omega_i = \omega_i^* + m_Q \cdot Q_i, \quad E_i = E_i^* + n_P \cdot P_i \quad (7)$$

where n_P and m_Q are the active and reactive droop coefficients in P - V and Q - f droop control, respectively. However, many problems cannot be solved by using the conventional P - V and Q - f droop control, such as line impedance dependency, inaccurate active power or reactive power regulation and slow transient response [93], [94]. In [46], the improved P - V and Q - f droop control is written:

$$\omega_i = \omega_i^* - m_i \cdot (P_i - Q_i), \quad E_i = E_i^* - n_i \cdot (P_i + Q_i). \quad (8)$$

Equation (8) shows that the improved P/V and Q/f droop control can simplify the coupled active and reactive power relationships, and a good dynamic performance can be achieved in case of resistive networks. Moreover, except for introducing derivative control into the droop method [33], [95], [96], an enhanced resistive droop method (RDM) is proposed to guarantee the voltage regulation and enhance power sharing performance [97], which can be obtained as:

$$E_i = E_i^* - (m_i + m_{D,s})P_i, \quad \omega_i = \omega_i^* + \left(n_p + \frac{n_i}{s} + n_{D,s} \right) Q_i \quad (9)$$

where n_P is another reactive power droop gain, and m_D and n_D are the active and reactive derivative droop coefficients, respectively. The enhanced RDM is adopted to eliminate the inherent contradiction between voltage regulation and power sharing performance, and the stability of microgrid can be improved under resistive feeder impedance condition.

D. Active Power Sharing Strategies under Unknown Feeder Impedance Condition

In many existing literatures, the networked-based active power sharing strategies are proposed [98], [99]. However, there are two major drawbacks: 1) The frequency drops cannot be eliminated due to the presence of the frequency and voltage droop loops. 2) The communication delays would increase system sensitivity under parameter uncertainties [99].

An improved networked-based power sharing strategy is presented in [34] to share active power under unknown impedance condition and the control function in time-domain can be obtained:

$$\delta_{DG_i}^*(t) = \omega_{nl} t + \left(\gamma_P \cdot \bar{P}_{tot} - P_i \right) \times \left(\frac{m_i}{s} + K_{P_i} \right) \quad (10)$$

where ω_{nl} is the frequency when DG operates at no load condition, γ_P is the desired share of the active power generated by the DG_i , \bar{P}_{tot} is the total average active power. K_{P_i} is the additional active power sharing controller gain, and $\delta_{DG_i}^*$ is the command angle

of DG_i . The distributed power regulators are located at each DG unit to obtain the delay-free local power measurement. Note that the improved control strategy can achieve the equivalent active power sharing while maintaining the steady-state frequency constant. Besides, this method improves dynamic performance of MG and minimizes active power sharing errors under unknown line impedances, and the high reliability and robustness of the MG system can be achieved against network failures.

E. Proportional Active Power Sharing Strategies Based on Nonlinear Cost Function

A common variable-based proportional active power sharing strategy is proposed in [100] for inverters with resistive output impedance, which is modified as:

$$E_i = \int [K_e \cdot (E_i^* - V_{com}) - K_q \cdot P_i] dt \quad (11)$$

where K_e and K_q are integral gains and V_{com} is the common voltage. Although this control strategy can achieve proportional load sharing and be robust to the system parameter variations, it needs the load voltage information and the common voltage may not exist in complex microgrids. Besides, the criterion for power sharing should no longer be a simple proportional relation based on the generator ratings when economical dispatching is introduced in hierarchical control [47], [53], [98]. Several nonlinear cost-based droop schemes have been presented by using a single second-order reference cost function for formulating frequency and voltage offsets added to the conventional droop equations [101], and a cost-based droop scheme is presented in [102] to realize active power sharing considering reducing the generation cost of the microgrid.

An optimal power sharing strategy is presented in [35] to guarantee the proportional power sharing and increase active power generation of DG units, and decrease the generation cost of the microgrid. The generation cost for the DG_i can be approximated as:

$$C_i(P_i) = \alpha_i P_i^2 + \beta_i P_i + \gamma_i \quad (12)$$

where α_i , β_i and γ_i are the gain parameters. Combining the auxiliary controllers, $m_{p_j} P_j = m_{p_i} P_i$ can be obtained in finite time and the minimal total cost of generation can be achieved while satisfying

system active power balance requirement. Note that the whole system is fully distributed and the dynamic performances of the secondary controllers can be guaranteed.

F. Proportional Active Power Sharing Based on Linear Cost Function

Compared with the existing nonlinear cost-based schemes, the control schemes with linear droop functions can be used to optimize the total generation cost. When high-cost of load exists in DG units, a linear cost-prioritized droop scheme is presented in [103] to reduce active power sharing. In addition, an improved linear power sharing cost-based schemes for DG units are presented in [36] to reduce the total generation cost of the autonomous microgrid. The cost saving is realized by tuning the DG droop gradients in accordance to their respective maximum generation costs, and the active power sharing is implemented easier with reduced cost. A linear cost-based droop scheme is given in (13) and (14).

$$f_{ref,i} = \left(f_{max} - \frac{f_{max} - f_{min,i}}{P_{max,i}} \times P_i \right) \quad (13)$$

$$f_{min,i} = f_{max} - \frac{f_{max} - f_{min}}{\max(C''_{max,1}, C''_{max,2}, C''_{max,3}, \dots, C''_{max,i}) \times C''_{max,i}} \quad (14)$$

where $f_{min,i}$ represents the minimum frequency of DG_i , f_{min} and f_{max} represent the maximum and minimum frequency, respectively. $C''_{max,i}$ represents the maximum cost incurred by DG_i , and $\max(C''_{max,i})$ is a function that returns the maximum cost among all DG units in the microgrid.

The principle of the derivation of maximum cost-based linear droop scheme utilizes the DG maximum generation costs to differentiate them on the droop plots so that the least costly DGs will have higher power generation. Therefore, the active power sharing can be achieved while reducing the total generation cost of MGs autonomously without compromising the flexibility of a linear droop implementation.

The advantages and disadvantages of the various methods for active power sharing in MG systems are summarized in Table II.

TABLE II.
Advantages and Disadvantages of Different Active Power Sharing Strategies

Active power sharing methods	Major technologies	Advantages	Disadvantages
Equivalent active power sharing with inductive feeder impedance	Adaptive droop control [33]. Optimized droop control [29], [87]	<ul style="list-style-type: none"> ● Achieve equivalent active power sharing ● Eliminate voltage and frequency deviation ● High disturbance rejection performance ● Improve the dynamic stability of active power sharing 	<ul style="list-style-type: none"> ● Not suitable for multiple DG units ● Not considering total cost of generation ● Proportional active power sharing is not achieved ● Not suitable for complex feeder impedance
P - V/Q - f droop control with resistive feeder impedance	Decoupling techniques [88-90]. Improved P - V and Q - f droop control [46], [91], [92]. Enhanced RDM [95-97]	<ul style="list-style-type: none"> ● Improve transient response ● Improve inherent contradiction between voltage and power sharing ● Improve the stability of microgrid 	<ul style="list-style-type: none"> ● Not suitable for complex MG ● Not considering total cost of generation ● Proportional active power sharing is not achieved
Active power sharing strategies under unknown impedance condition	Networked-based active power sharing schemes [34], [98], [99]	<ul style="list-style-type: none"> ● Improve dynamic performance of microgrid ● Improved active power sharing under unknown line impedance ● High robustness on communication delays 	<ul style="list-style-type: none"> ● Not considering total cost of generation ● Proportional active power sharing is not achieved
Proportional active power sharing strategies	A common variable-based active power sharing strategy [100]	<ul style="list-style-type: none"> ● Achieve proportional load sharing ● Eliminate voltage and frequency deviations ● Robust to the system parameter variations 	<ul style="list-style-type: none"> ● Sensitive to communication delays ● Not suitable for complex MG ● Not considering total cost of generation
	Nonlinear cost-based droop schemes [35], [101], [102]	<ul style="list-style-type: none"> ● Share active power ● Eliminate voltage and frequency deviation ● Minimize total cost of generation 	<ul style="list-style-type: none"> ● Cost function is difficult to be computed ● Not suitable for complex feeder impedance condition ● Not suitable for complex MG
	Linear cost function [36], [103]	<ul style="list-style-type: none"> ● Share active power ● Reduce the total generation cost of MGs easier and autonomously ● Eliminate voltage and frequency deviations 	<ul style="list-style-type: none"> ● Be sensitive to communication delays ● Not suitable for complex MG ● Not suitable for complex feeder impedance

III. BACKGROUND OF THE REACTIVE POWER SHARING IN ISLANDED MICROGRIDS

As discussed in section II, P - V and Q - f droop control are usually applied in a small system where the feeder impedance is more resistive, while P - f and Q - V droop control are used in a medium or large system where the feeder impedance is approximately inductive [47]. In this paper, the droop control (P/f , Q/V) for islanded MGs are discussed to evaluate the performance of reactive power sharing.

A. Problems of the Reactive Power Sharing in the Droop Control

In the conventional droop control, by combining (1) and (4), Q_i can be obtained as:

$$Q_i = \frac{V_{PCC}(E_i^* - V_{PCC})}{(X_i + X_{Li}) + n_i V_{PCC}} \quad (15)$$

where the reactive power of the DG is related to the feeder impedance, PCC voltage and reactive droop coefficient. It can be deduced from (15), although the two DG units (in Fig. 2) have the same capacity and reactive power droop coefficients, the reactive power of the DG₁ can also be smaller than DG₂ under a mismatched feeder impedance condition ($X_1 > X_2$) [18].

Fig. 3 shows the voltage deviation problem of the reactive power sharing in conventional droop control method. E^* is reference voltage and E_1^* is larger than E_2^* in Fig. 3. When the reactive droop coefficient is n_1 , DG₁ and DG₂ operate at E , while DG₁ and DG₂ operate at E' when the reactive droop coefficient is n_2 . A and B indicate that the reactive power of DG₁ is Q_1' (droop coefficient n_1) and Q_1'' (droop coefficient n_2), respectively. C and D indicate that the reactive power of DG₂ is Q_2' (droop coefficient n_1) and Q_2'' (droop coefficient n_2), respectively. The reactive power difference of DG₁ and DG₂ is ΔQ ($Q_1' - Q_2'$) when they operate at E , and the difference is $\Delta Q'$ ($Q_1'' - Q_2''$) when they operate at E' . Although ΔE is smaller than $\Delta E'$, ΔQ is larger than $\Delta Q'$ (when $n_2 > n_1$). Therefore, the reactive power deviation can be reduced by increasing the droop coefficient, but it will cause a large voltage deviation in the steady state [82], [84], [104].

B. Problems of Reactive Power Sharing in the Secondary Control

In order to solve the problems caused by the conventional droop control, a secondary control is used to eliminate the frequency and voltage deviations [105], [106].

Fig. 4 shows the classical secondary control scheme for the two parallel-DGs in islanded MG. The output frequency (f_{MG}) and voltage (V_{MG}) of the MG are compared with the frequency and voltage references, respectively. The frequency/voltage deviation ($\Delta f/\Delta V$) is then adjusted through proportional-integral (PI) controller. The adjusted frequency and voltage of the MGCC are sent to the primary and inner control loop through a communication lines to regulate the initial voltage and frequency references [105].

The reactive power sharing is poor when the voltage is regulated by using the conventional secondary control. When two identical DGs are connected to a common distribution bus, as shown in Fig. 4, the two feeder reactances are different ($X_1 > X_2$). Besides, a phase-locked loop (PLL) is needed to calculate V_{MG} and f_{MG} from the measured voltage at PCC.

The E - Q droop characteristics with and without a conventional secondary control are depicted in Fig. 5 [73]. The blue/green dashed line is the secondary control curve for DG₁/DG₂ and the black solid line is the conventional droop control curve. In Fig. 5(a), A (Q_1, E_1) and C (Q_2, E_2) represent the output voltage of DG₁ with the injection of reactive power Q_1 is E_1 and the voltage of DG₂ with Q_2 is E_2 in the conventional droop control, respectively. B (Q_1', E^*) and D (Q_2', E^*) represent the output reactive power of DG₁ is Q_1' and DG₂ is Q_2' when the voltage is restored to the rated value E^* in the conventional

secondary control. However, the reactive power deviation between DG₁ and DG₂ increases ($Q_1' < Q_1 < Q_2 < Q_2'$).

The situation in Fig. 5(b) can be obtained by one of the schemes presented in next section. As shown in Fig. 5(b), when the reactive power is regulated as $Q_1 = Q_2 = Q''$ (a special situation of proportional reactive power sharing) in the conventional secondary control, B' (Q'', E_1'') and D' (Q'', E_2'') are the output voltages of DG₁ (E_1'') and DG₂ (E_2''), respectively. However, the voltages of DG₁ and DG₂ cannot be restored to the rated values and the voltage difference is larger compared to the primary control ($E_2 < E_2'' < E_1 < E_1''$). Therefore, the conventional secondary control cannot regulate the voltage accurately while sharing the reactive power equally or proportionally [73].

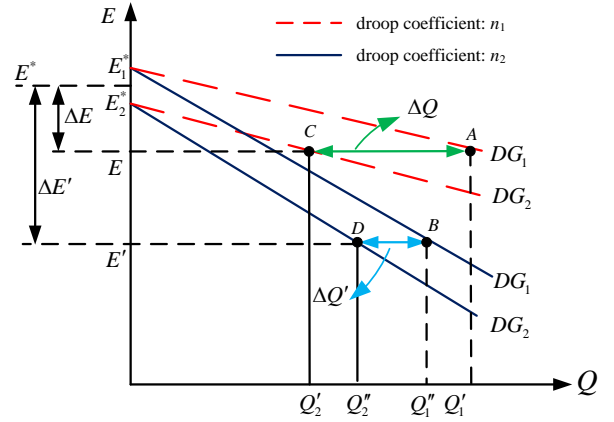

Fig. 3. Characteristic curves of the reactive power droop control with two DGs [104].

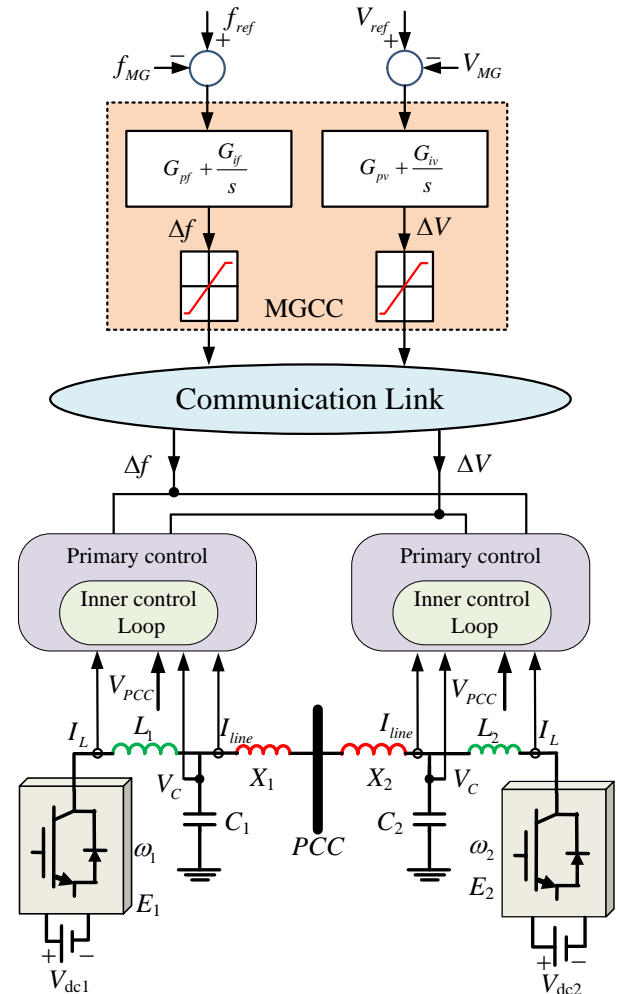

Fig. 4. The conventional secondary control for two parallel-DGs in the MG operating in islanded mode [105].

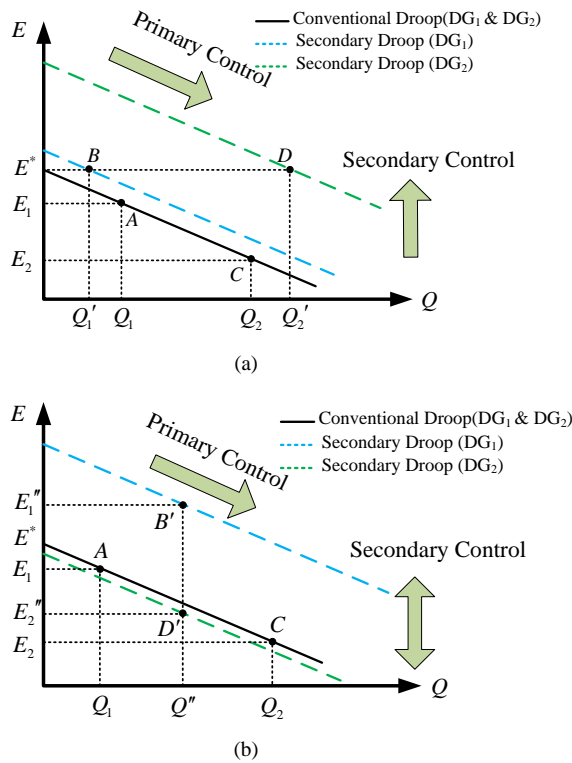

Fig. 5. Diagram of the secondary control for the islanded microgrid. (a) E - Q droop curve when the voltage is restored to the rated value. (b) E - Q droop curve when the reactive power sharing is achieved ($X_1 > X_2$) [73].

C. Conventional Reactive Power Sharing Strategies in the Secondary Control

It is well-known that the reactive power sharing is poor under the mismatched feeder impedance and complex load conditions in the conventional droop control. To solve the problem of reactive power sharing in the secondary control, some control strategies have been suggested by many literatures [61], [63], [72], [107-112].

A decentralized self-adjusting control strategy for reactive power management is presented in [63] to prevent reactive power circulation among the DG units under unequal feeder impedance condition. A virtual inductive impedance loop is utilized to enhance the steady-state precision and transient responses for reactive power sharing. Although the complex load conditions are not considered, it has presented an idea to share the reactive powers by combining adaptive control strategy and virtual impedance.

In [107], a robust nonlinear distributed controller is presented to maintain the stability of the active and reactive powers, and ensure faster response when MG operates on different conditions (three-phase short-circuit fault, loads changes, etc.). Combining with the genetic algorithm, an improved virtual impedance controller is utilized to minimize the global reactive power sharing error [108], and gives a good direction to design algorithms by utilizing the knowledge on computer science, mathematical science, etc. The reactive power sharing and voltage restoration method is presented in [109], which employs both consensus control and adaptive virtual impedance control for islanded MG under mismatched feeder impedance. Moreover, a consensus-based distributed voltage control for reactive power sharing is presented in [72] to guarantee the desired reactive power distribution in the steady state, and shows that the distributed regulation is less sensitive to the failure of communication links. Therefore, when a sparse communication structure is used, improved stability and reliability of complex MG systems can be ensured [72], [109].

In summary, frequency and voltage stability, and accurate reactive power sharing are all important performance criteria in MG

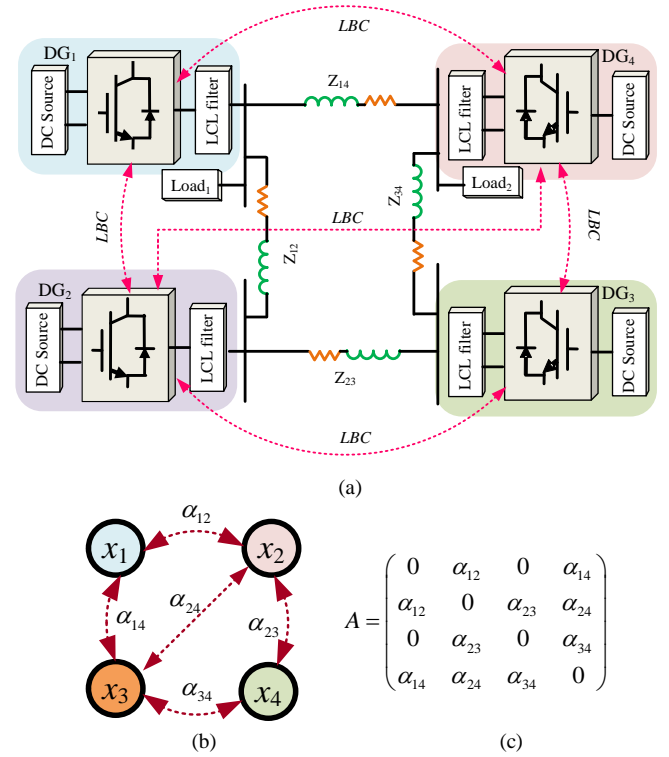

Fig. 6. The physical model and adjacency matrix for four DG units based islanded MG. (a) The physical model of the microgrid with four DG units. (b) The graph representation of the physical model. (c) The adjacency matrix of the graph [74].

systems [59], [110-112]. Therefore, the conventional hierarchical control strategies need to be improved, in order to share the active and reactive powers in complex MGs, and the schemes to realize the reactive power sharing in the improved hierarchical control strategies are analyzed in detail in the forthcoming sections.

IV. REACTIVE POWER SHARING WITH MISMATCHED FEEDER IMPEDANCE

In the conventional secondary control, the reactive power sharing cannot be achieved when the voltage amplitude and frequency are restored to the rated value in islanded MGs with mismatched feeder impedance. Currently, the most popular methods to solve these problems can be summarized into three main categories: optimized the secondary control equations [72], [113-117], programming algorithm [19], [74], [121-123] and multi-agent system (MAS) algorithms [72], [76], [113], [133].

A. Control Methods Based on Graph Theory

1). Graph Theory

Considering the theory of weighted graph in discrete mathematics, a multi-agent cyber-physical system can be expressed with a graph from the perspective of control methods, where agents (sources) are modeled as nodes of the graph and communication links are mapped to edges connecting nodes [74], [79]. The model of MG is shown in Fig. 6 (a) and its equivalent weighted graph is in Fig. 6 (b). The DG_{*i*} is represented by node x_i in Fig. 6 (b) and the edge lines (double arrows in Fig. 6 (b)) indicate that communication link among the DG units. Fig. 6(c) shows that the adjacency matrix $\mathbf{A} = [\alpha_{ij}] \in \mathbf{R}^{N \times N}$ is the $n \times n$ weighted adjacency matrix of the graph with elements $\alpha_{ij} = \alpha_{ji} \geq 0$. The weight of edge is denoted by (v_j, v_i) , and $\alpha_{ij} = 0$ when there is no communication between DG_{*i*} and DG_{*j*}. Note that the adjacency matrix \mathbf{A} is usually a sparse matrix and only low bandwidth communication is needed in the hierarchical control algorithm [113], [114].

In addition, the in-degree matrix $\mathbf{D} = \text{diag} \in \mathbf{R}^{N \times N}$ is defined as a diagonal matrix with $d_i = \sum_{j \in N_i} \alpha_{ij}$ and the corresponding Laplacian matrix is defined as $\mathbf{L} = \mathbf{D} - \mathbf{A}$. A graph is called to have a spanning tree, when all nodes have a directed path to a root node. Moreover, a graph carries the minimum redundancy if it contains sufficient redundant links, and the graph will remain connected and present a balanced Laplacian matrix, where any individual link fails [115], [116].

Since complex model of MG is analyzed by the graph theory, the control algorithm can be improved effectively by using \mathbf{A} , \mathbf{D} , \mathbf{L} and other reasonable parameters. Note that an equation and two theorems are always used in the control algorithm based on the graph theory:

$$\dot{x}_i = u_i = \sum_{j \in N_i} a_{ij} (x_j - x_i) \quad (16)$$

where any scalar x_i must satisfy the principle of distributed averaging (consensus) in the continuous time. In addition, the two important theorems in the graph theory are described as [117]:

Theorem I: If there is a spanning tree in the communication graph, consensus control can be reached and the Laplacian matrix L has a simple zero eigenvalue and all the other eigenvalues have positive real parts.

Theorem II: If there is a spanning tree in the communication graph and a root node i satisfying $i \in B$, all agents' states will converge to the external control signal v .

Theorems I and II are often used in the consensus control to analyze the stability of MG systems [72]. Moreover, almost all the algorithms based on graph theory satisfy (16) to ensure the selected variable to be equal to a known parameter in the steady state.

According to (16), it is assumed that x_j is equal to ω_i and x_i is equal to ω_i^* , and the angular frequency of MG is equal to the nominal angular frequency ($\omega_i = \omega_i^*$) in the steady state.

2). Reactive Power Sharing with Mismatched Feeder Impedance Based on Graph Theory

i. The distributed average proportional integral (DAPI) control method based on the graph theory is presented in [73] to share the reactive power. The optimized secondary control equations can be described by (17)-(19), where the Ω_i/e_i is only an integral term in the conventional secondary control method.

$$\omega_i = \omega^* - m_i P_i + \Omega_i, \quad E_i = E^* - n_i Q_i + e_i \quad (17)$$

$$k_i \frac{d\Omega_i}{dt} = -(\omega_i - \omega^*) - \sum_{j=1}^n \alpha_{ij} (\Omega_i - \Omega_j) \quad (18)$$

$$k_i \frac{de_i}{dt} = -\beta_i (E_i - E^*) - \sum_{j=1}^n b_{ij} \left(\frac{Q_i}{Q_i^*} - \frac{Q_j}{Q_j^*} \right) \quad (19)$$

where gain coefficients β_i and k_i are all positive, and define an n -order matrix \mathbf{B} which is composed of b_{ij} ($b_{ij} > 0$). In the DAPI control scheme, the conventional current and voltage control loops, active and reactive power droop control loops and virtual impedance loops are all applied in the primary control [82], [85], [118-120].

According to (16), $(k_i \frac{de_i}{dt})' = 0$ can be achieved to share the reactive power in the steady state. If $\beta = 0$ and $\mathbf{B} \neq 0$, then:

$$\frac{Q_i}{Q_i^*} = \frac{Q_j}{Q_j^*}. \quad (20)$$

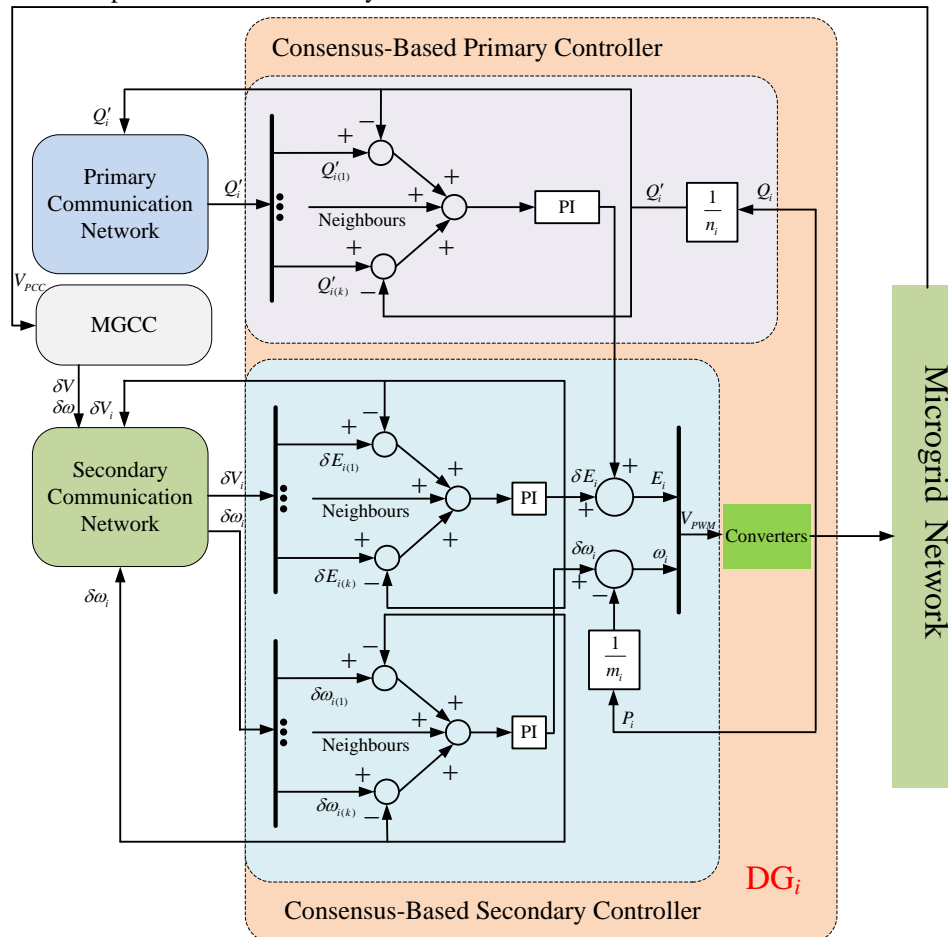

Fig. 7. The control structure of the consensus algorithm based on the hierarchical control [117].

Equation (20) shows that the equivalent reactive power sharing is achieved. Moreover, $E_i = E^*$ can be achieved when $\beta \neq 0$ and $\mathbf{B} = 0$.

Therefore, the reactive power sharing can be realized and the voltage can be restored to the rated value when $\beta \neq 0$ and $\mathbf{B} \neq 0$. Although the DAPI controllers can be tuned to enforce either voltage regulation, reactive power sharing, or a compromise between the two, the proportional reactive power sharing and accurate voltage regulation cannot be achieved. Moreover, the reactive power capacity and LBC delay are not considered [73].

ii. A consensus-based distributed control method is presented in [117] to achieve the proportional reactive power sharing by integrating the droop and secondary control, where only a sparse network is required.

The consensus-based primary and secondary control is shown in Fig. 7. The voltage reference is obtained by eliminating the reactive power and voltage amplitude mismatch among DG units through PI controllers. In addition, the reference frequency can be regulated by consensus-based secondary controller. Note that the identical Q_i/n_i can be achieved by using the protocol in the consensus-based primary controller. According to (16), x_i is replaced by a controllable variable v_i :

$$\dot{v}_i = \sum_{j \in N_i} \left(\frac{Q_j}{n_j} - \frac{Q_i}{n_i} \right) \quad (21)$$

where $\dot{v}_i = 0$ and $Q_i/n_i = Q_j/n_j$ in the steady state.

According to (16), the control signal \dot{v}_i is sent to a set of networked agents with only sparse communication links, and the reactive power sharing is achieved by using the consensus control protocol in the consensus-based secondary controller:

$$\delta \dot{E}_i = \sum_{j \in N_i} (\delta E_j - \delta E_i) + b_i (\delta E - \delta E_i). \quad (22)$$

According to **Theorem II**, all local δE_i will converge to δE in the steady state. Note that the communication line exists in DG_i and DG_j when $b_i=1$, or there is no communication line between them when $b_i=0$.

The consensus control parameters track the reference signal δE through the MGCC, and the secondary control signals δE_i will be obtained under the different rated capacities of DG units and mismatched feeder impedance conditions. Furthermore, the reactive power sharing can be achieved and the voltage amplitude can be restored to the rated value by combining the consensus-based droop and secondary control algorithm.

Since the voltage regulation and reactive power sharing are realized by using a sparse communication with significantly lower bandwidth requirement, the communication cost can be greatly reduced. Note that the proportional reactive power sharing and voltage regulation can be achieved simultaneously in the consensus-based primary and secondary control. However, similar to the DAPI control method, the reactive power capacity and LBC delay are not considered in [117].

B. Reactive Power Sharing Considering Characteristics of the RES

The active power of the RES fluctuates greatly, the poor active and reactive power sharing are inevitable when the environment changes. If the active power is extracted from the maximum power point tracking (MPPT) algorithms, the stability of MG system may be affected and overload may occur in the system [74]. Therefore, the algorithms for sharing active and reactive powers mentioned in the preview section may not be applicable, which may affect the stability of MGs.

1). Programming Algorithms for the Reactive Power Management in the MG with RES

The core of the programming algorithm is ‘‘procedural’’, and the design of such algorithm mainly relies on the three characteristics

[121-123]:

- (1) *Finiteness*: The algorithm can stop after a finite number of steps.
- (2) *Definiteness*: Every step of the algorithm should be clearly defined. Moreover, results of each step can be effectively implemented.
- (3) *Sequentiality*: From the initial step, every step is the prerequisite for the next step.

In addition, iterative method, dynamic programming method, branch/bound method and nested loop algorithm can all achieve the control for one DG to n DG units (e.g. the reactive power sharing between two DG units is extended to n DG units) [19], [74], [121-123]. A reasonable algorithm can improve the reliability of the system and simultaneously reduce the cost of the hardware investment [124-129].

Considering the capacity limitation of individual RES, a control method based on programming-algorithm is presented in [74] to share the reactive power and limit the apparent power of each converter to be lower than its rated value.

The relationship between the maximum apparent power Q_{\max} and reactive power is:

$$Q_{\max} = \sqrt{S_N^2 - P^2} \quad (23)$$

where Q_{\max} is the maximum reactive power of the converter. S_N is the nominal apparent power of the converter. The constraint conditions of the reactive power sharing can be obtained as:

$$P_i^2 + Q_i^2 = S_i^2 \leq S_{Ni}^2, \quad Q_{\max i} = \sqrt{S_{Ni}^2 - P_i^2} \quad (24)$$

where S_i and S_{Ni} are the apparent power and the nominal power of the i^{th} converter. When the converters are operating with apparent powers higher than the nominal power, the reactive powers of these converters need to be limited. But the capacity of reactive powers of the unlimited converters are free, whose apparent powers are lower than nominal values. Specifically, the proportional reactive power sharing (PRPS) algorithm can be simplified to the following steps.

The first step is to calculate the total active power P_L , reactive power Q_L and the maximum of possible reactive power of converter $Q_{\max i}$, and P_L , Q_L are derived as:

$$P_L = \sum P_i, \quad Q_L = \sum Q_i. \quad (25)$$

The second step is to analyze whether the reactive power of each DG exceeds the reactive power limit and regulate Q_i of limited converters. Moreover, an intermediate variable is utilized to save all the reactive power of unlimited converters to make them equal to Q_i .

The third step is to obtain the adjusted reactive power (Q_{ui}) for converters by the preset algorithm [74]. The PRPS algorithm can realize the proportional reactive power sharing among n DG units. However, it is still difficult to design a programming algorithm that can accelerate the computing and processing speed, and reduce the communication cost in the existing literatures.

2). The Reactive Power Management in a Multi-Agent Based RES System

The MAS is a group or organization of autonomous computational entities (agents) that communicates in a peer-to-peer fashion, which has the capacity to perceive its environment and solve control problems effectively in complex systems [130], [131]. The agents have varying degrees of intelligence based on their roles and the architecture, which can be categorized into passive agents, active agents and complex agents [132]. Besides, the agents pursue global views for the system and accomplish goals by using of knowledge and optimizing the certain performance within a special environment [133], [134]. In addition, agents have the capability to interact with other agents, which involve negotiation or cooperation.

TABLE III.

Advantages and Disadvantages of the Improved Hierarchical Control Strategies for Reactive Power Sharing Considering the Mismatched Feeder Impedance or Changeable Production and load

Major techniques	Reactive power sharing problems	Advantages	Disadvantages
Optimized the secondary control equations [72], [113-117]	The reactive power is affected by unequal feeder impedance	<ul style="list-style-type: none"> •Be suitable for a complex MG •Active power sharing is achieved •Frequency deviation is eliminated •Reactive power sharing is realized without high bandwidth communication •The control law can be simplified by graph theory 	<ul style="list-style-type: none"> •Proportional reactive power sharing is difficult to be achieved •Communication delays exist in the LBC •Control equations need to be further optimized in the MG with complex loads
Programming algorithm [19], [74], [121-123]	Equipments may be damaged when RES operates using MPPT method due to overloading	<ul style="list-style-type: none"> •Proportional reactive power sharing can be achieved •The equipment safety is ensured •Good performance for expansibility •Be used to control complex DG units 	<ul style="list-style-type: none"> •The programming algorithm is difficult to be designed in a complex MG •Delay/data drop in algorithm need to be considered •Delays in algorithm need to be considered
Multi agent systems [76], [133]	The output active and reactive powers are affected by environment	<ul style="list-style-type: none"> •The stable active and reactive powers sharing can be achieved •The control law can be simplified by graph theory •Organize information autonomously computational entities •Be beneficial to exchange information 	<ul style="list-style-type: none"> •Communication delay is in LBC lines •Good protocol in agents is difficult to be designed •The active and reactive power sharing are poor when data drop exists in the preset algorithm

In a complex system, agents are required to exchange, analyze, process, accept and reject the information from other agents to reach a common goal under a changeable environment condition [135].

The RES is sensitive to the environment and it would affect the active and reactive power sharing of islanded MGs. However, the influence can be eliminated by the cooperation among agents. The decentralized secondary control method based on the MAS is presented in [76] to regulate the active and reactive powers. A set of control laws for agents in any given network can be derived by the secondary control and only local information is needed.

As shown in Fig. 8, the control scheme of the MG is depicted and the bottom layer is composed of DG units with local controllers, and the top layer is encompassed by the agents and the communication network. The agents connected to an uncontrollable or partially controllable DG (represented by circle) are called controllable and partially controllable agents, respectively. The other agents are called controllable agents (represented by diamond). When the output power of the RES starts to change, uncontrollable agents receive information from their corresponding uncontrollable DGs and then send the information to adjacent controllable agents according to the preset control method. These controllable agents adjust the corresponding controllable DGs to get the desired active and reactive powers. The active power production of DG₁ depends on environment (e.g. PV panel depends on sunlight) and it will be larger once the intensity of sunlight increases. Since the controllable DG₂ is adjacent to DG₁, Agent₁ and Agent₃ will send the information to Agent₂ (neighbours Agent₁ and Agent₃), respectively. And the output power of the controllable DG₂ is regulated by Agent₂, making the total active power to the desired value.

In the communication network, agents exchange information and make decisions according to the preset control laws, which include the environment, the load demands and the delay, etc. Although the power rating of a RES is usually designed along with the active power generation, the reactive power of the system can be utilized to supply the apparent power to reduce the active power requirement. When the information is sent to the controllable DG units by corresponding agents, a MAS can be used to regulate the active and reactive powers properly after the powers at the next time instants are estimated. Therefore, the output power of DG units can be regulated by local controls under the changeable environmental conditions to achieve a balance between the production and

consumption of the energies in the MG.

Considering the capacity of the reactive power and changeable production and load, a well-designed MAS algorithm can achieve equivalent or proportional reactive power sharing. However, the communication delay is also inevitable in the MAS.

The advantages and disadvantages of the various methods for the reactive power sharing under the mismatched feeder impedance and changeable environmental conditions are summarized in Table III.

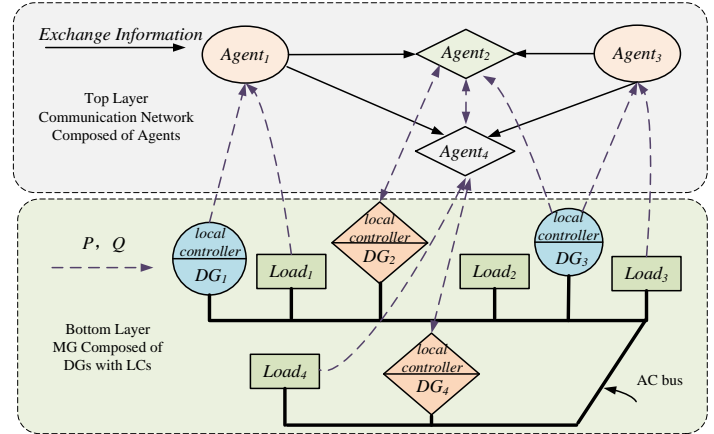

Fig. 8. Control scheme of the multi-agent based islanded MG system [76].

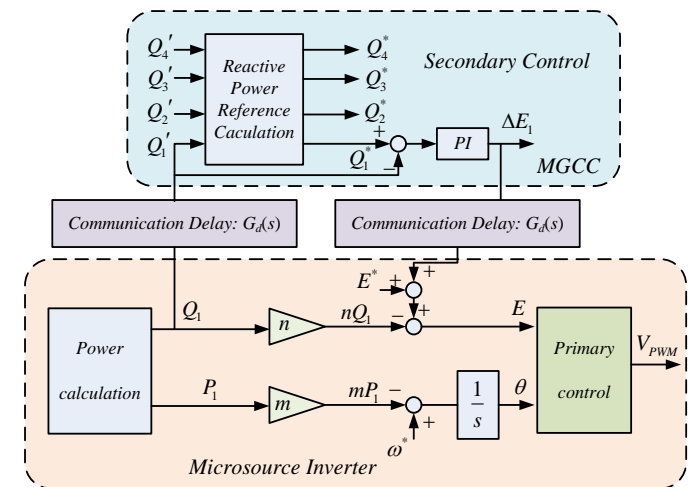

Fig. 9. Control scheme of a DG with mismatched reactive power compensating [141].

V. REACTIVE POWER SHARING WITH MISMATCHED FEEDER IMPEDANCE

It is well-known that output powers of MGs with RESs are affected by the feeder impedance and the loading/production of power. Moreover, the reactive power sharing would be poor due to the nonlinear and unbalanced loads in the islanded mode [64], [84], [136-140].

A. Direct Control Methods for the Reactive Power Sharing

The main task of direct control methods for the reactive power sharing is to get the required value in each DG, do the sum of these values, and then assign these adjusted powers to each DG on average (weighted average) [141]. In [141], each converter is responsible for providing the information of the required reactive power to the MG via low bandwidth communications links. In addition, the MGCC determines the way that how the reactive power supplies for each converter.

Fig. 9 shows a distributed control scheme for eliminating reactive power mismatched in an islanded MG, where the reactive power Q_i obtained from the droop control is sent to the secondary control to make a sum, and the Q_i^* obtained from the secondary control is sent to the primary control through PI controller. Moreover, the compensation of the droop control E^* is adjusted by ΔE_1 . The reactive power demand Q_i^* for each converter can be calculated by:

$$Q_i^* = \frac{\sum Q_i}{n_i (\sum_{i=1}^k \frac{1}{n_i})} \quad (26)$$

where $\sum Q_i$ is the total reactive power supplied by all the converters. Q_i^* is the reactive power demand supplied to the i^{th} converter and n_i is the droop gain of the i^{th} converter. The MGCC is responsible for regulating the reactive powers according to the reactive power reference of each converter, and the communication delay $G_d(s)$ is defined as:

$$G_d(s) = \frac{1}{T_d s + 1} \quad (27)$$

The control method shown in Fig. 9 can solve the problem of the equivalent or proportional reactive power sharing with a certain communication delay. The values of the reactive power are extracted directly and not affected by load impedance, thereby this control method is suitable for both the linear and nonlinear load conditions. However, the communication delay is always uncertain and it may result in a poor reactive power sharing.

B. Indirect Methods for the Reactive Power Sharing

Compared to the direct methods for sharing the reactive power, the indirect methods are more comprehensive. Note that the default variable is controlled to share the reactive power indirectly in the indirect control schemes, and more factors that may affect the reactive power sharing are considered [73] [117].

A two-layer cooperative method that controls the voltage/frequency as well as the active/reactive power is presented in [142], as shown in Fig. 10. The voltage controlled voltage source inverters (VCVSI) are used to eliminate the voltage and frequency deviations in the first layer, and the current controlled voltage source inverters (CCVSI) are responsible for sharing the active and reactive powers in the second layer. In summary, the control objectives of the VCVSI are to regulate voltage magnitude and frequency, and CCVSI are used to control output active and reactive power of each DG in the two-layer distributive cooperative control. Note that a sparse network needs to be constructed by the graph theory, and each DG only requires its neighbour and own information on the LBC network [113-116].

1) Frequency Control of VCVSIs

The control of the voltage and frequency is utilized to synchronize all voltages and frequencies of the VCVSI to nominal voltage and frequency, respectively. The assumption that makes the frequencies restored to the rated values is based on (28)-(31) as:

$$m_1 P_1 = \dots = m_i P_i \quad (28)$$

$$v_{fi} = \dot{\omega}_i + m_i \dot{P}_i \quad (29)$$

$$\omega_i = \int v_{fi} dt \quad (30)$$

$$v_{fi} = -c_{fi} \left(\sum_{j \in N_i} a_{ij} (\omega_i - \omega_j) + g_i (\omega_i - \omega_{ref}) + \sum_{j \in N_i} a_{ij} (m_i P_i - m_j P_j) \right) \quad (31)$$

where v_{fi} is an auxiliary variable, which is chosen based on each VCVSI's own and the neighbour information in the communication graph. ω_i is the input angular frequency controlled by v_{fi} , and c_{fi} is the control gain and $g_i \geq 0$. It is assumed that VCVSIs can communicate with each other through the communication graph to achieve the synchronization. According to (16), it can be obtained that every DG can operate at the same frequency in the steady state.

2) Reactive Power Control of CCVSI

The reactive power of CCVSI is set based on their reactive power ratings as:

$$\frac{Q_i}{Q_1} = \dots = \frac{Q_i}{Q_i^*} = \alpha_{Q_{ref}} \quad (32)$$

According to each CCVSI and its adjacent information, the auxiliary control v_{Qi} can be chosen as:

$$v_{Qi} = -c_{Qi} \left(\sum_{j \in N_i} a_{ij} \left(\frac{Q_i}{Q_i^*} - \frac{Q_j}{Q_j^*} \right) + g_i \left(\frac{Q_i}{Q_i^*} - \alpha_{Q_{ref}} \right) \right) \quad (33)$$

where $\alpha_{Q_{ref}}$ represents the pre-specified reactive power ratio reference, and c_{Qi} and g_i are the control gains.

Considering the consensus principle of (16), the Q_i/Q_i^* can be synchronized to a reference value, and equivalent or proportional reactive power sharing can be achieved. Although the algorithm in two-layer control is complex, it is not affected by the feeder impedance and it is suitable for sharing the reactive power in islanded MG with unbalanced and nonlinear loads.

C. The Reactive Power Sharing in the Hierarchical Control Strategies with Harmonic Compensation

A frequency droop control with additional disturbance is utilized to produce some active power sharing variations to regulate the DG virtual impedances at the fundamental positive sequence, fundamental negative sequence, and harmonic frequencies under the unknown feeder impedance, and achieves the reactive power sharing by combining variable virtual impedance with the frequency droop control in [143]. In [70], the positive- and negative-sequence components of the voltage and current are applied to calculate positive-sequence active and reactive powers, respectively. The output voltage and phase angle references are obtained by the positive-sequence powers, and then the voltage unbalance can be compensated by negative-sequence reactive power. Finally, the voltage is well-regulated and the reactive power sharing is realized in the MG with nonlinear load.

Fig. 11 shows a classical approach to share the reactive power. The load voltage harmonics are eliminated by the harmonic compensation algorithms, and the deviations of voltage amplitude and frequency are compensated by the secondary control. In addition, the active and reactive powers can be shared by combining the virtual impedance and secondary control [144]. Each converter is required to transmit the reference reactive power to the MG (Q_1 and Q_2) by using the MGCC, and the MGCC determines how the total reactive power is allocated to each converter (Q_1^* and Q_2^*).

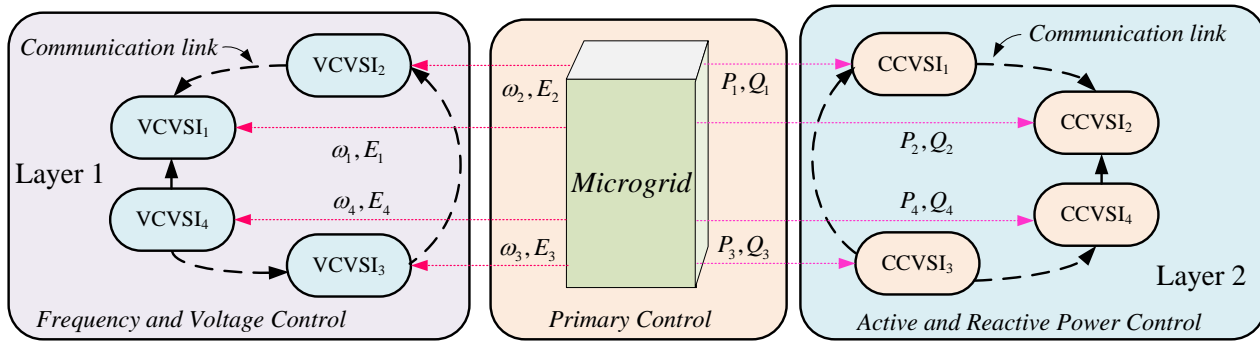

Fig. 10. Scheme of the two-layers distributed control in the islanded microgrid [142]

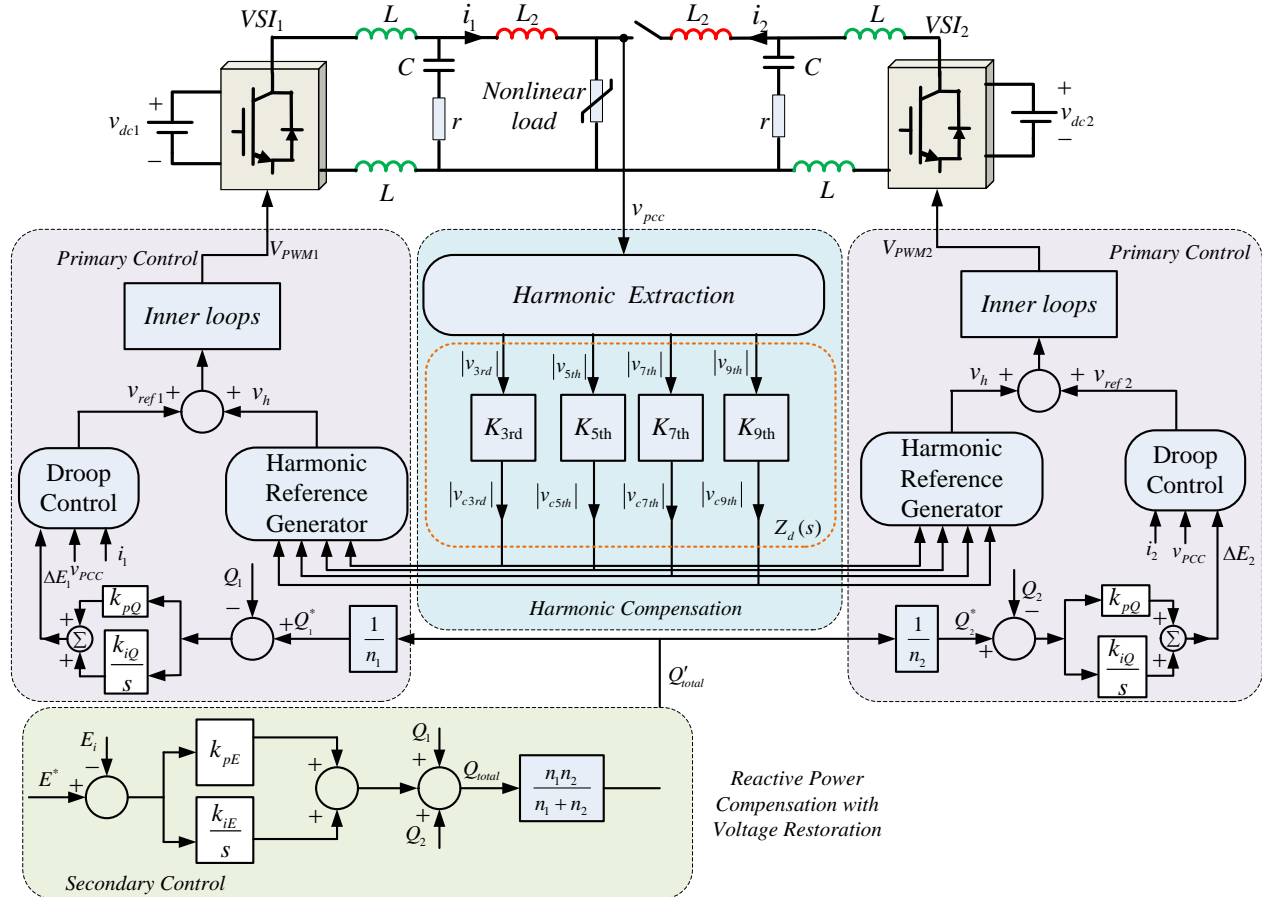

Fig. 11. Block diagram of the reactive power sharing of islanded MG including harmonic compensation loops [144].

TABLE IV.

Advantages and Disadvantages of the Different Control Strategies for Reactive Power Sharing under Nonlinear or Unbalanced Load Conditions

Control methods	Advantages	Disadvantages
Integration of the MGCC and the primary control [64], [141]	<ul style="list-style-type: none"> The equivalent/proportional reactive power sharing is realized Method is easy to expand First-order communication delay is considered Be suitable for linear or nonlinear load conditions 	<ul style="list-style-type: none"> Cannot share the reactive power in islanded microgrid with more complex loads Without considering communication delay Without considering data drop in communication lines
The hierarchical control based on graph theory [73], [117], [142]	<ul style="list-style-type: none"> The two-layer control is fully distributed and will not affect each other. The proportional reactive power sharing can be achieved The model is suitable for a complex MG The control method is suitable for islanded MG with nonlinear load conditions 	<ul style="list-style-type: none"> Total generation cost of MGs is not considered The algorithm is complex Without considering LBC delay The performance of controller is affected by data drop
Integration of secondary control and virtual impedance loop [70], [143], [144]	<ul style="list-style-type: none"> Suppress harmonic voltage effectively The stability of the system is enhanced The equivalent/proportional reactive power sharing is realized Influence on nonlinear load is considered 	<ul style="list-style-type: none"> The influence of feeder impedance is not considered Not suitable for large scale MGs Poor expandability of the control strategy The reactive power sharing is influenced by LBC delay

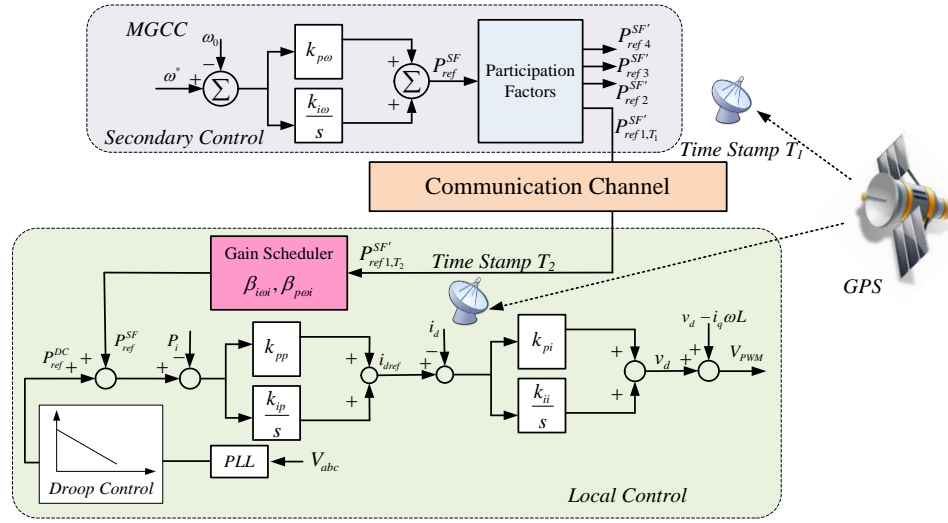

Fig. 12. Scheme of gain-scheduling method for compensating the communication delay [77].

The formula of computing the reactive power demand (Q_i^*) is the same as (26) and the reactive power sharing compensator for any converter i can be expressed as:

$$\Delta E_i = k_{pQS} (Q_i^* - Q_i) + k_{iQS} \int (Q_i^* - Q_i) dt \quad (34)$$

where k_{pQS} and k_{iQS} are the control gains and ΔE_i is the additional voltage deviation which is added to the droop control loop.

The harmonic compensation loop is used to improve the power quality and stability of the MG. Specifically, the harmonics caused by the nonlinear load are compensated by harmonic controller, and a resistive virtual impedance R_V is used to improve the stability of the microgrid. The transfer function of virtual impedance can be obtained as:

$$Z_d(s) = R_V - \sum_{n=3,5,7,9,\dots} \frac{\omega_{cn} k_{cn}}{s^2 + \omega_{cn} s + \omega_n^2} \quad (35)$$

where $Z_d(s)$ is the virtual impedance transfer function. k_{cn} are the harmonic resonant gains, ω_{cn} are the harmonic resonant bandwidths and ω_n is the n^{th} harmonic frequency. The voltage across the capacitor of the output filter can be expressed as:

$$V_h(s) = V_{ref}^*(s) - i_k(s) Z_d(s) \quad (36)$$

where $V_{ref}^*(s)$ is the reference voltage that is determined by the outer droop control loop. $V_h(s)$ is the compensated input to the inner loops and $i_k(s)$ is the output current of the k^{th} inverter. The harmonic compensation is used to damp the voltage harmonics at the PCC. In addition, a secondary voltage harmonic compensation loop can be applied to further reduce the voltage harmonics at the PCC. Overall, the improved reactive power sharing strategy with harmonic compensation controller achieves the reactive power sharing while eliminates the voltage and frequency deviations.

The advantages and disadvantages of the various control methods for reactive power sharing in islanded MGs with nonlinear and unbalanced load conditions are summarized in Table IV.

VI. PROBLEMS OF COMMUNICATION DELAY IN THE HIERARCHICAL CONTROL

The communication delay always exists in both the secondary and multi-agents control. The frequency and voltage amplitude are restored to the rated value in the hierarchical control, but the output correction signals sent to primary control need a time delay owing to the communication lines. Therefore, these signals may be different to the theoretical values, which will cause damage to MGs. However, the communication delay problems have not yet been considered in many studies.

A. Reduce the Impact of Delay through a Gain Scheduler

The delay in the communication lines between local control and MGCC has been mentioned in [77], the characteristic of the delay can be constant, bounded, or random in terms of the network structure. The washout filter-based power sharing strategy with no communication line is presented in [145] to replace the secondary control and eliminate the impact on delay, but the nonlinear and unbalanced loads are not considered.

Usually, when secondary control is used in active and reactive power sharing strategies to eliminate the frequency and voltage deviations, the communication delays cannot be ignored. Many literatures have presented various gain scheduling methods to deal with the problems brought by time-delay in a complex MG system [146-149]. The gain scheduling approach is presented in [77] to compensate the effect of the communication delay on the secondary frequency control to guarantee the active power sharing and stable operation of the MG.

As shown in Fig. 12, there are conventional droop control and current loop in the local control, which are used to regulate the output active and reactive powers and output current. Besides, the local control is equipped with a gain scheduler to counteract the communication delay and the PLL is utilized to measure the MG frequency. The active power references for each DG are calculated by the secondary frequency controller to restore the frequencies to the nominal value and sent to local converters. These references are obtained by $P_{ref,i,T1}^{SF}$, where T_1 is the time stamp (sent by the MGCC). The references are marked as $P_{ref,i,T2}^{SF}$, where T_2 is another time stamp (received by local control). The communication delay $\tau_i = T_2 - T_1$ is calculated by comparing the two signals $P_{ref,i,T2}^{SF}$ and $P_{ref,i,T1}^{SF}$. To counteract the effect of communication delay, a gain scheduling approach is used in secondary controller with the following transfer function:

$$\bar{G}_{if} = \beta_{ioi} G_{if}, \quad \bar{G}_{pf} = \beta_{poi} G_{pf} \quad (37)$$

where G_{if}/G_{pf} are fixed integral/proportional coefficient in the secondary frequency controller. β_{ioi}/β_{poi} denotes an changeable integral/proportional gain scheduler, and \bar{G}_{if} and \bar{G}_{pf} are the equivalent gains of the secondary frequency controller after gain schedulers equipped in each local control. Considering (37), the equalized load frequency controller has the following form:

$$P_{ref,i}^{SF} = \left(G_{pf} + \frac{\bar{G}_{if}}{s} \right) (\omega_i^* - \omega_i), \quad P_{ref,i}^{SF} = \left(\bar{G}_{pf} + \frac{G_{if}}{s} \right) (\omega_i^* - \omega_i) \quad (38)$$

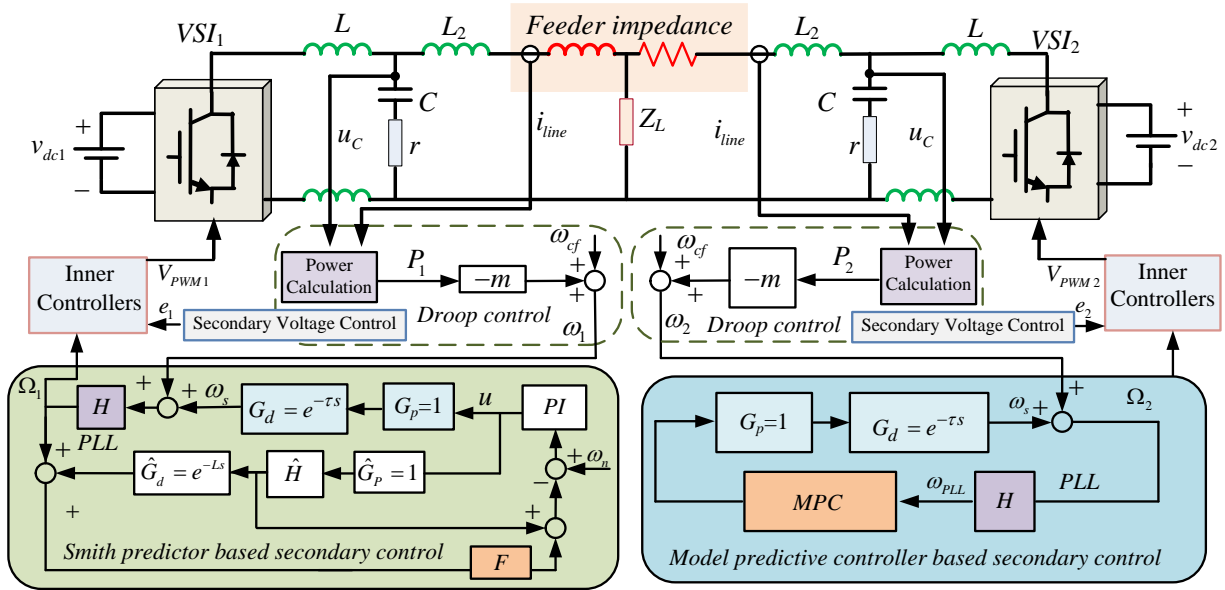

Fig. 13. Control scheme of the frequency secondary control with the predictive controller [78].

where P_{refi}^{SF} is the supplementary power set point of the i^{th} DG assigned by the secondary frequency controller. Equation (38) can be utilized to investigate the root locus of the time-delay small-signal model to find optimal β_{ioi} and β_{poi} and the stable operation of the microgrid system could be guaranteed under different LBC delay conditions. In addition, the cost function J is built to find the relationships between the gain-scheduler variables and the system performance of the MG, which is defined as:

$$J = \frac{1}{T} \int_{t=0}^T (\omega_{i,d}(t) - \omega_i(t))^2 \quad (39)$$

where the frequency of the DG $_i$ when the microgrid operates with and without communication delays are represented by $\omega_{i,d}(t)$ and $\omega_i(t)$, respectively. Considering relationships between the time delay τ_i and its corresponding feasible gain $\beta_{ioi}^{\tau_i}/\beta_{poi}^{\tau_i}$, a proper cost index is needed to be built to obtain the gain value of different MGs. After a certain delay margin is obtained by taking into account the relationship between the cost function and the gain variable, the impact of communication delays on the LBC lines can be compensated while the performance of active power sharing is guaranteed by the gain scheduling method. And the communication delays on management of reactive power can also be eliminated when the gain scheduling methods are further improved.

B. Reducing the Impact of Delay by using Predictive Control

As known in [77], [78] and [150-152], secondary frequency controller is affected by the LBC delays and then the poor active power sharing is inevitable in the hierarchical control. Generally, predictive control is used to deal with the LBC delay problems. In [150] and [151], the predictive control method is presented to compensate for the impact on the communication delay and data loss. In addition, the model predictive controller (MPC) and smith predictor (SP) are presented to solve the problems brought by communication delays [78], [152].

As shown in Fig. 13, the output current of the converter is passed through an LCL filter to reject the high-frequency switching noise. In addition, the capacitor voltage and output currents of each converter are sent to the droop controllers to calculate the active and reactive powers. Droop controllers set the voltage and frequency references based on the generated active and reactive powers. Moreover, the output frequency and voltage are adjusted by SP or

MPC. When the control systems are decoupled, the characteristic equation of the secondary control system (SCS) is obtained as [78]:

$$1 + e^{-s\tau} G_p G_c H = 0 \quad (40)$$

where H is the PLL transfer function. $e^{-s\tau}$ is the transfer function of the communication delay. G_c is the delay transfer function of PI controllers and G_p is the delay transfer function of the system device to be controlled. It can be inferred that the accurate estimation of the delay transfer functions in a typical operating point is required when a SP is implemented in the secondary frequency controller, which is shown in Fig. 13. For the MPC, a set of future control actions needs to be calculated by optimizing a cost function with constraints on the manipulated and controlled variables.

In summary, the MPC and SP controllers can be used to test the unknown communication delays in a MG. Specifically, in the MPC-based SCS, the future behavior is predicted by optimizing a cost function with constraints on the controlled variables in the MG. The dynamic performance of the MPC is slower than the SP, but the MPC is more robust to time delays and preferred to operate in systems with unknown communication delays. In addition, the reactive power sharing performance of a well-designed algorithm can be further improved, and the system can be immune to the communication delay by using the MPC and SP controllers.

C. The Reactive Power Sharing Scheme Considering Feeder Impedance, Complex Loads and Communication Delay

Considering the communication delay, the secondary control strategy for the reactive power sharing is facing challenges and it is difficult to solve this problem effectively. The distributed cooperative control method for large-scale DGs with time-varying delays is presented in [153] to achieve the reactive power sharing. A more comprehensive method is presented in [79] to combine the advantages of primary and secondary control. A weighted graph is used to replace the actual information system and the control algorithm is further optimized to achieve the reactive power sharing. Specifically, this method is based on the voltage, reactive power and active power regulator modules in the MG.

As shown in Fig. 14, each inverter is considered as an agent of a multi-agent system to exchange data with a few other neighbor inverters, and process the information to update its local voltage set points and synchronize their normalized power and frequencies. Moreover, global voltage regulation, frequency synchronization and

proportional load sharing can be achieved by the cooperation among voltage, reactive power and active power regulators effectively in a fully distributed control strategy, and the stability and robustness of MG can be improved. Specifically, the node i receives the information Ψ_j from its neighbors node j , and regulate the neighbor and local data Ψ_i to update its voltage and frequency references (E_i^* and ω_i). The voltage reference is obtained by two voltage correction terms (δE_i^1 and δE_i^2) from the voltage and reactive power regulators, and the reactive power and frequency can be regulated by eliminating the reactive power and frequency deviations among the neighbors through PI controllers. Then, the reference voltage E_i^* of DG_i can be obtained as:

$$E_i^*(t) = E^* + \delta E_i^1(t) + \delta E_i^2(t) \quad (41)$$

$$m_{Q_i} = \sum_{j \in N_i} b\alpha_{ij}(Q_j^* - Q_i^*), \quad \delta\omega_i = \sum_{j \in N_i} c\alpha_{ij}(P_j^* - P_i^*) \quad (42)$$

where E^* is the rated voltage magnitude of the MG. The voltage regulator at node i is compared with the rated voltage E^* , where the difference is fed to a PI controller ($G_i(s)$) to generate the first voltage

correction term δE_i^1 , b and c are gain coefficients. The neighborhood reactive loading mismatch m_{Q_i} , which measures the difference between the normalized reactive power of the source i and the average value of its neighbors, and the mismatch in (42) is then fed to a PI controller ($H_i(s)$) to adjust the second voltage correction term δE_i^2 . The frequency correction term $\delta\omega_i$ represents the information of neighborhood active loading mismatch.

Due to the performance of the PI regulator, all reactive powers will be synchronized to the same value and reactive power sharing is achieved. The active power regulator module keeps the frequency at the rated value, and precisely tunes the phase angle reference $\delta\omega_i^*$ to reroute the active power across the MG and mitigates the neighborhood active power mismatch.

In order to reduce the impact of LBC delay, the cooperative distributed control strategy is tested to find a delay margin to ensure controller parameter immunity and stability of the MG. In addition, the equivalent active and reactive powers can be shared when the LBC delay is constrained within the delay margin [79], [154].

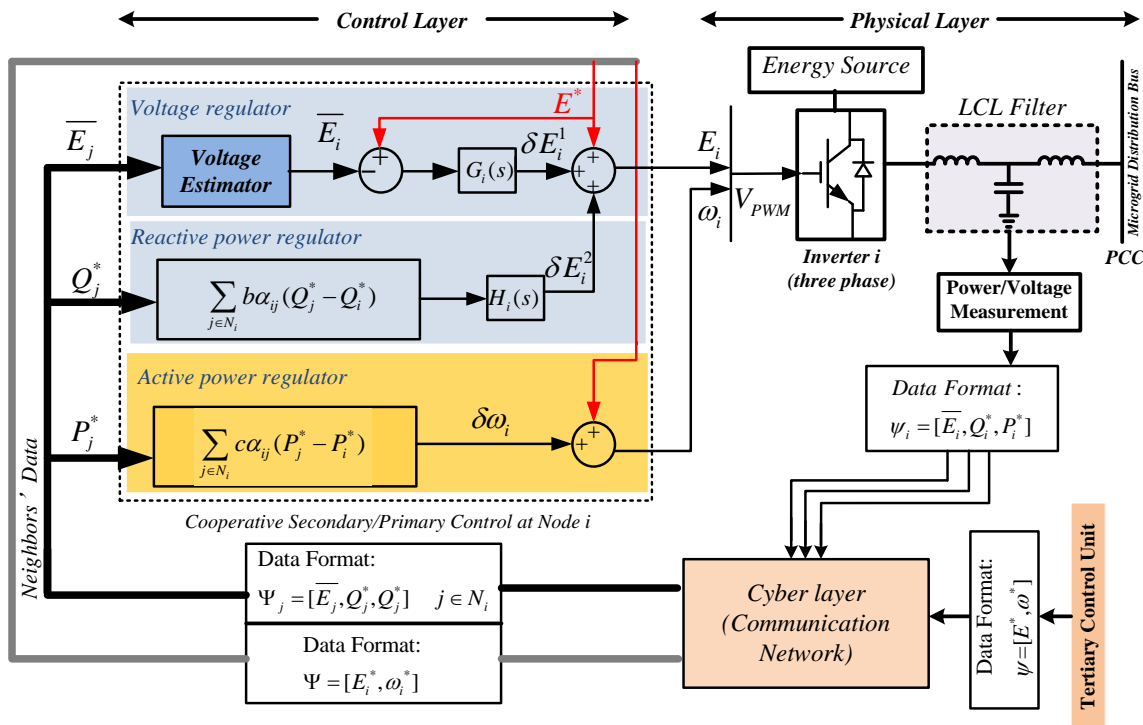

Fig. 14. Control scheme for the cooperative distributed control in islanded microgrid [79].

TABLE V.

Advantages and Disadvantages of Different Hierarchical Control Strategies Considering the Effect of Communication Delay

Control methods	Major technologies	Advantages	Disadvantages
Gain scheduling method [77] [146-149]	The data from the MGCC is adjusted by the gain scheduler	<ul style="list-style-type: none"> Provides a general model Reduce the cost by designing the reasonable cost function The system can guarantee a good power sharing in the delay margin 	<ul style="list-style-type: none"> Gain coefficients are not easy to select Communication delay in reactive power controllers is not considered Data drop is not considered
Predictive control [78], [150-152]	Predict the unknown delay by the SP or MPC	<ul style="list-style-type: none"> Good robustness to the constant communication delay Provides a general model The system can guarantee a good power sharing in the delay margin 	<ul style="list-style-type: none"> The algorithm is complex Poor expandability Cannot deal with the problems brought by random delay
Cooperative distributed control [79], [153]	A sparse network is needed and share the active and reactive powers by the distributed control	<ul style="list-style-type: none"> The equivalent active and reactive power sharing can be achieved under complex load conditions Good plug-and-play capability Have resiliency to a single communication link failure Good robustness to the constant communication delay 	<ul style="list-style-type: none"> Data drop is not considered Cannot deal with the problems brought by random delay The proportional reactive power can not be realized

In the cooperative distributed control strategy, MG can run at the rated voltage and angular frequency, combining the active power regulator, the voltage and reactive power regulators. The cooperative distributed controller can realize the equivalent reactive power sharing under the mismatched feeder impedance and nonlinear load conditions when the LBC delay is within the delay margin, but proportional active and reactive power sharing cannot be achieved. Different hierarchical control strategies for eliminating the LBC delays in MGs are summarized in Table V.

VII. DISCUSSION ON FUTURE TRENDS

From the previous discussion, it can be seen that each of these control techniques has its own characteristics, advantages and disadvantages. Microgrids can be better utilized when the problems of load active and reactive power sharing are effectively solved. The future trends on MG research and application can be summarized as follows [155-169].

A. Advanced Distributed Control in Microgrids

With a high penetration level of the DG units, the research on how to realize accurate active and reactive power sharing among multiple DG units, improve the robustness and reliability of the system and simultaneously optimize/eliminate the energy flow using the graph theory/predictive control/multi-agent systems has been a mainstream trend [155], [156].

A microgrid model can be simplified by graph theory, and the complexity of an algorithmic design can be further reduced. The multi-agent cooperative control method for coordinating power allocation between the ultra-capacitors and batteries distributed throughout the microgrid is presented in [155]. Besides, a predictive control is designed in [156] to achieve the active and reactive power sharing with nonlinear load, which indicates that the future predictive control needs to be improved in order to deal with the effect of harmonic and unbalanced loads.

B. Control for Microgrids with Complex Loads

The methods for active and reactive power sharing in microgrids with linear load are well developed, but it is still difficult to ensure the reactive power sharing when microgrids supply complex loads such as dynamic loads, induction motor, the pulsed loads and the electric vehicles, etc. The realization of the reactive power sharing in such variable loads is one of the important directions in the future research [157-160].

The situation of different nonlinear loads is analyzed in [157], and the results from its experiments indicate that the actual operation of the microgrid is influenced by different load conditions. The microgrid with sensitive loads discussed in [158], and a new method to supply energy for the loads by using the fuel cell as energy storage equipment is proposed. A hybrid DC power system is designed in order to supply a pulsed load [159]. Moreover, a plug and play method is presented in [160] when the microgrid supplies the sensitive and unbalanced loads, which enhances the power quality.

C. Cost-Prioritized Control Schemes

It is important to minimize the operation cost and coordinate supporting services, meanwhile maximizing the reliability and controllability of microgrids. Therefore, optimization of the MG cost function is one of the trends in the future research [161-164].

Considering realistic values for the bids, actual market prices, typical load profiles and renewable productions, the economic evaluation of a microgrid participating in a real-time market is obtained in [161], which shows that the economical microgrid operation can reduce energy prices for the consumers and increase

revenues for the aggregator. A genetic algorithm is used in [162] to reveal the economic benefits of both distribution network and microgrid. A directly operating schedule for a whole day is presented in [163], which allocates the power to the loads in an optimal strategy by constructing the cost function reasonably. A short-time predictive control is presented in [164] to regulate the active and reactive powers in the microgrid, and coordinate the optimal operation of dispatchable resources and the daily costs of the energy imported from the grid.

D. Reduce the Impact of Communication Delay

The control methods are always involved with the transmission of data when multiple DG units are connected, but the delay is inevitable in both low and high bandwidth communication lines. Therefore, it is important to consider the load power sharing problem in the constant, bounded, or random delay. Furthermore, it is essential to develop stability analysis tools for practical cases in the future.

The open communication infrastructures including Ethernet, Internet, worldwide interoperability for microwave access (WiMax), and wireless fidelity (WiFi) are increasingly implemented for smart grid communications [165-169]. However, the delay or data loss may occur during their transmission. Therefore, the solution to decrease the cost and increase the delay margin is one of important research directions of microgrids in the future.

VIII. CONCLUSION

This paper presents an overview of the different active and reactive power sharing methods. Owing to the limitation of the conventional droop and secondary control, the poor active and reactive power sharing of the DG units are inevitable. A comprehensive analysis and comparison of the improved control methods to share the active and reactive power have been presented.

In a complex MG, the dynamic stability of active power sharing needs to be enhanced and some improved droop control methods are analyzed in this paper to achieve the optimized active power sharing. Considering that the active power may be affected by feeder impedance, this paper presents some improved P - V and Q - f droop control schemes to share the active power under resistive/unknown feeder impedance conditions. Moreover, as economic problem is considered in hierarchical control, the criterion for active power needs to be established on generation cost of the microgrid, and various linear/nonlinear cost-based schemes are analyzed in this paper to optimize active power sharing and minimize the total cost of generation simultaneously.

Most of the existing methods only consider the reactive power sharing under linear load conditions with mismatched feeder impedance. However, a poor reactive power sharing may exist when MGs operate on mismatched feeder impedance, nonlinear and unbalanced load conditions. Therefore, the algorithms based on graph theory, multi-agent systems, predictive control and cooperative distributed control have been discussed in detail to share the reactive powers under these complex circumstances.

In addition, owing to the low bandwidth communication lines in the hierarchical control, the transmission speed of the upper control is much lower than the response rate in the primary control. Therefore, this paper analyzes the problems on LBC delay in the hierarchical control and presents some solutions to solve these problems, such as gain scheduling scheme and predictive control methods.

Finally, the future trends of the control technologies in MGs are discussed. The ways to simplify the complicated control algorithm and decrease the low bandwidth communication by graph theory,

process and optimize the performance of MGs by MAS, improve power quality of MGs with RES by predictive control and enhance the robustness of MGs to the unknown environmental factors under the high penetration of DG units have become the mainstream trends. In addition, the analysis for the relationship among the cost, the design and the operation of MGs are still the main topics in the future research of MGs.

REFERENCES

- [1] F. Blaabjerg, Z. Chen and S. B. Kjaer, "Power electronics as efficient interface in dispersed power generation systems," *IEEE Trans. Power Electron.*, vol. 19, no. 5, pp. 1184-1194, Sep. 2004.
- [2] C. S. Wang, X. S. Yang, Z. Wu, Y. B. Che, L. Guo, S. H. Zhang, and Y. X. Liu, "A highly integrated and reconfigurable microgrid tested with hybrid distributed energy sources," *IEEE Trans. Smart Grid.*, vol. 7, no. 1, pp. 451-459, Jan. 2016.
- [3] H. M. Xiao, S. X. Ling, L. S. Bo, Z. Z. Kui, "Transient analysis and control for microgrid stability controller," in *proc. IEEE Grenoble Power Tech. (POWERTECH)*, 2013, pp. 1-6.
- [4] Q. Fu, L. F. Montoya, A. Solanki, A. Nasiri, V. Bhavaraju, T. Abdallah, and D. C. Yu, "Microgrid generation capacity design with renewables and energy storage addressing power quality and surety," *IEEE Trans. Smart Grid.*, vol. 3, no. 4, pp. 2019-2027, Dec. 2012.
- [5] Y. Zhang, H. J. Jia, and L. Guo, "Energy management strategy of islanded microgrid based on power flow control," in *proc. IEEE PES Innovative Smart Grid Technologies (ISGT)*, 2012, pp. 1-8.
- [6] N. K. Ardesna, and B. H. Chowdhury, "Supporting islanded microgrid operations in the presence of intermittent wind generation," in *proc. IEEE Power and Energy Society General Meet.*, 2010, pp. 1-8.
- [7] C. S. Wang, M. X. Liu, and L. Guo, "Cooperative operation and optimal design for islanded microgrid," in *proc. IEEE PES Innovative Smart Grid Technologies (ISGT)*, 2012, pp. 1-8.
- [8] T. Logenthiran, D. Srinivasan, A. M. Khambadkone and T. S. Raj, "Optimal sizing of an islanded microgrid using evolutionary strategy," in *proc. 11th IEEE International Probabilistic Methods Applied to Power Systems. Conf. (PMAPS)*, 2010, pp. 12-17.
- [9] T. L. Vandoorn, T. Loix, L. Vandeveldel, B. Meersman and J. Driesen, "Influence of power control strategies on the voltage profile in an islanded microgrid," in *proc. 14th IEEE International Harmonics and Quality of Power. Conf. (ICHQP)*, 2010, pp. 1-8.
- [10] J. Liu, Y. Miura, H. Bevrani and T. Ise, "Enhanced virtual synchronous generator control for parallel inverters in microgrids," *IEEE Trans. Smart Grid.*, vol. PP, no. 99, 2016.
- [11] R. Majumder, A. Ghosh, G. Ledwich and F. Zare, "Operation and control of hybrid microgrid with angle droop controller," in *proc. IEEE 10th Region TENCON Conf.*, 2010, pp. 509-515.
- [12] R. Majumder, A. Ghosh, G. Ledwich and F. Zare, "Angle droop versus frequency droop in a voltage source converter based autonomous microgrid," in *IEEE Power and Energy Society General Meeting (PES)*, 2009, pp. 1-8.
- [13] E. Barklund, N. Pogaku, M. Prodanovic, C. H. Aramburo, and T. C. Green, "Energy management in autonomous microgrid using stability-constrained droop control of inverters," *IEEE Trans. Power Electron.*, vol. 23, no. 5, pp. 2346-2352, Sep. 2008.
- [14] S. D. Arco and J. A. Suul, "Equivalence of virtual synchronous machines and frequency-droops for converter-based microgrids," *IEEE Trans. Smart Grid.*, vol. 5, no. 1, pp. 394-395, Jan. 2014.
- [15] S. D. Arco and J. A. Suul, "A synchronization controller for grid reconnection of islanded virtual synchronous machines," in *proc. IEEE 6th International Power Electronics for Distributed Generation Systems Symposium (PEDG)*, 2015, pp. 1-8.
- [16] S. D. Arco and J. A. Suul, "Virtual synchronous machines-classification of implementations and analysis of equivalence to droop controllers for microgrids," in *proc. IEEE Grenoble PowerTech (POWERTECH)*, 2013, pp. 1-7.
- [17] J. Liu, Y. Miura and T. Ise, "Comparison of dynamic characteristics between virtual synchronous generator and droop control in inverter-based distributed generators," *IEEE Trans. Power Electron.*, vol. 31, no. 5, pp. 1-1, May. 2016.
- [18] Y. W. Li and C. N. Kao, "An accurate power control strategy for power-electronics-interfaced distributed generation units operating in a low-voltage multibus microgrid," *IEEE Trans. Power Electron.*, vol. 24, no. 12, pp. 2977-2988, Dec. 2009.
- [19] C. F. Gao, R. G. Yang, J. Jiao, and Z. H. Dou, "Power control strategy design in an islanded microgrid based on virtual frequency," in *proc. IET 2nd Renewable Power Generation Conf. (RPG)*, 2013, pp. 1-4.
- [20] Y. D. Chen, A. Luo, J. Zhou, L. S. Bai, and C. M. Tu, "Rapid reactive power control method for parallel inverters using resistive-capacitive output impedance," in *proc. 1st International Future Energy Electronics Conf. (IFEEC)*, 2013, pp. 98-102.
- [21] F. Gao, S. Bozhko, G. Asher, P. Wheeler and C. Patel, "An improved voltage compensation approach in a droop-controlled DC power system for the more electric aircraft," *IEEE Trans. Power Electron.*, vol. PP, no. 99, 2016.
- [22] H. G. Xiao, A. Luo, Z. K. Shuai, G. B. Jin and Y. Huang, "An improved control method for multiple bidirectional power converters in hybrid AC/DC microgrid," *IEEE Trans. Smart Grid.*, vol. 7, no. 1, pp. 340-347, Jan. 2016.
- [23] H. C. Chiang, K. K. Jen and G. H. You, "Improved droop control method with precise current sharing and voltage regulation," *IET Power Electron.*, vol. 9, no. 4, pp. 789-800, 2016.
- [24] U. Borup, F. Blaabjerg, and P. Enjeti, "Sharing of nonlinear load in parallel connected three-phase converters," *IEEE Trans. Ind. Appl.*, vol. 37, no. 6, pp. 1817-1823, Nov./Dec. 2001.
- [25] T. Lin and P. Cheng, "Design of a new cooperative harmonic filtering strategy for distributed generation interface converters in an islanding network," *IEEE Trans. Power Electron.*, vol. 22, no. 5, pp. 1919-1927, Sep. 2007.
- [26] M. C. Chandorkar, D. M. Divan and R. Adapa, "Control of parallel connected inverters in standalone AC supply system," *IEEE Trans. Ind. Appl.*, vol. 29, no. 1, pp. 136-143, Jan./Feb. 1993.
- [27] J. Guerrero, L. de Vicuna, J. Matas, M. Castilla, and J. Miret, "A wireless controller to enhance dynamic performance of parallel inverters in distributed generation system," *IEEE Trans. Power Electron.*, vol. 19, no. 5, pp. 1205-1213, Sep. 2004.
- [28] S. J. Chiang, C. Y. Yen, and K. T. Chang, "A multi module parallelable series-connected PWM voltage regulator," *IEEE Trans. Ind. Electron.*, vol. 48, no. 3, pp. 506-516, Jun. 2001.
- [29] Y. A. R. I. Mohamed, H. H. Zeineldin, M. M. A. Salama and R. Seethapathy, "Seamless formation and robust control of distributed generation microgrids via direct voltage control and optimized dynamic power sharing," *IEEE Trans. Power Electron.*, vol. 27, no. 3, pp. 1283-1294, Mar. 2012.
- [30] Y. A. R. I. Mohamed and E. F. E. Saadany, "Adaptive decentralized droop controller to preserve power sharing stability of paralleled inverters in distributed generation microgrids," *IEEE Trans. Power Electron.*, vol. 23, no. 6, pp. 2806-2816, Nov. 2008.
- [31] S. J. Ahn, J. W. Park, I. Y. Chung, S. I. Moon, S. H. Kang and S. R. Nam, "Power-sharing method of multiple distributed generators considering control modes and configurations of a microgrid," *IEEE Trans. Power Del.*, vol. 25, no. 3, pp. 2007-2016, Jul. 2010.
- [32] A. Ghazanfari, M. Hamzeh, H. Mokhtari and H. Karimi, "Active power management of multihybrid fuel cell/supercapacitor power conversion system in a medium voltage microgrid," *IEEE Trans. Smart Grid.*, vol. 3, no. 4, pp. 1903-1910, Dec. 2012.
- [33] Y. A. R. I. Mohamed and A. A. Radwan, "Hierarchical control system for robust microgrid operation and seamless mode transfer in active distribution systems," *IEEE Trans. Smart Grid.*, vol. 6, no. 4, pp. 352-362, Jun. 2011.
- [34] A. Kahrabaiean and Y. A. R. I. Mohamed, "Networked-based hybrid distributed power sharing and control for islanded microgrid systems" *IEEE Trans. Power Electron.*, vol. 30, no. 2, pp. 603-617, Feb. 2015.
- [35] G. Chen and E. Feng, "Distributed secondary control and optimal power sharing in microgrids," *IEEE Trans. J. Autom. Sinca.*, vol. 63, no. 1, pp. 304-312, Jan. 2016.
- [36] I. U. Nutkani, P. C. Loh, P. Wang and F. Blaabjerg, "Linear decentralized power sharing schemes for economic operation of AC microgrids," *IEEE Trans. Ind. Electron.*, vol. 63, no. 1, pp. 225-234, Jan. 2016.
- [37] H. Hua, Y. Liu, Y. Sun, M. Su and J. M. Guerrero, "An improved droop control strategy for reactive power sharing in islanded microgrid," *IEEE Trans. Power Electron.*, vol. 30, no. 6, pp. 3133-3141, Jun. 2015.
- [38] J. M. Guerrero, L. G. D. Vicuna, J. Matas, M. Castilla, and J. Miret, "Output impedance design of parallel-connected ups inverters with wireless load-sharing control," *IEEE Trans. Ind. Electron.*, vol. 52, no. 4, pp. 1126-1135, Aug. 2005.
- [39] H. Mahmood, D. Michaelson and J. Jiang, "Reactive power sharing in islanded microgrids using adaptive voltage droop control," *IEEE Trans. Smart Grid.*, vol. 6, no. 6, pp. 3052-3060, Nov. 2015.
- [40] J. W. He, and Y. W. Li, "An enhanced microgrid load demand sharing strategy," *IEEE Trans. Power Electron.*, vol. 27, no. 9, pp. 3984-3995, Sep. 2012.
- [41] P. Li, X. B. Wang, W. J. Lee, and D. Xu, "Dynamic power conditioning method of microgrid via adaptive inverse control," *IEEE Trans. Power Del.*, vol. 30, no. 2, pp. 906-913, Apr. 2015.
- [42] K. D. Brabandere, B. Bolsens, J. V. D. Keybus, A. Woyte, J. Driesen and R. Belmans, "A voltage and frequency droop control method for parallel inverters," *IEEE Trans. Power Electron.*, vol. 22, no. 4, pp. 1107-1115, Jul. 2007.
- [43] M. Q. Mao, Z. Dong, Y. Ding, and L. C. Chang, "A unified controller for a microgrid based on adaptive virtual impedance and conductance," in *proc. IEEE Energy Conversion Congress and Exposition (ECCE)*, 2014, pp. 695-701.

- [44] Y. J. Gu, W. H. Li, and X. N. He, "Frequency-coordinating virtual impedance for autonomous power management of DC microgrid," *IEEE Trans. Power Electron.*, vol. 30, no. 4, pp. 2328-2337, Apr. 2015.
- [45] P. Sreekumar, and V. Khadkikar, "A new virtual harmonic impedance scheme for harmonic power sharing in an islanded microgrid," *IEEE Trans. Power Del.*, vol. PP, pp. 1-1, 2015.
- [46] W. Yao, M. Chen, J. Matas, J. M. Guerrero and Z. M. Qian, "Design and analysis of the droop control method for parallel inverters considering the impact of the complex impedance on the power sharing," *IEEE Trans. Ind. Electron.*, vol. 58, no. 2, pp. 576-588, Feb. 2011.
- [47] J. M. Guerrero, M. Chandorkar, T. Lee and P. C. Loh, "Advanced control architectures for intelligent microgrids-part I: decentralized and hierarchical control," *IEEE Trans. Ind. Electron.*, vol. 60, no. 4, pp. 1254-1262, Apr. 2013.
- [48] H. Han, X. C. Hou, J. Yang, J. Wu, M. Su and J. M. Guerrero, "Review of power sharing control strategies for islanding operation of AC microgrids," *IEEE Trans. Smart Grid.*, vol. 7, no. 1, pp. 200-215, Jan. 2016.
- [49] M. Savaghebi, Q. Shafiee, J. C. Vasquez and J. M. Guerrero, "Adaptive virtual impedance scheme for selective compensation of voltage unbalance and harmonics in microgrids," in *proc. IEEE, Power and Energy Society General Meet.*, 2015, pp. 1-5.
- [50] H. Mahmood, D. Michaelson and J. Jiang, "Accurate reactive power sharing in an islanded microgrid using adaptive virtual impedances," *IEEE Trans. Power Electron.*, vol. 30, no. 3, pp. 1605-1617, Mar. 2015.
- [51] J. W. He, Y. W. Li, J. M. Guerrero, F. Blaabjerg and J. C. Vasquez, "Microgrid reactive and harmonic power sharing using enhanced virtual impedance," in *proc. IEEE 28th Applied Power Electronics Conference and Exposition Annu. Conf. (APEC)*, 2013, pp. 447-452.
- [52] Z. Yixin, L. Baoquan, W. Feng, Z. Fang and Z. Yangjie, "A virtual resistance based reactive power sharing strategy for networked microgrid," in *proc. 9th International Power Electronics and ECCE Asia Conf. (ICPE-ECCE Asia)*, 2015, pp. 1564-1572.
- [53] J. M. Guerrero, J. C. Vasquez, J. Matas, V. G. D. Vicuna, and M. Castilla, "Hierarchical control of droop-controlled AC and DC microgrids-a general approach toward standardization," *IEEE Trans. Ind. Electron.*, vol. 58, no. 1, pp. 158-172, Jan. 2011.
- [54] W. H. Yun, Z. Z. ChuN, Y. Q. Fang, B. Wei, H. G. Qing, H. G. Hui, and F. K. Hui, "A hierarchical control of microgrid based on droop controlled voltage source converter," in *IEEE PES Asia-Pacific Power and Energy Engineering Conf. (APPEEC)*, 2013, pp. 1-4.
- [55] S. K. Khadem, M. Basu and M. F. Conlon, "Intelligent islanding and seamless reconnection technique for microgrid with UPQC," *IEEE J. Emerg. Sel. Topics Power Electron.*, vol. 3, no. 2, pp. 483-492, Jun. 2015.
- [56] A. Micallef, M. Apap, C. S. Staines and J. M. Guerrero, "Single-phase microgrid with seamless transition capabilities between modes of operation," *IEEE Trans. Smart Grid.*, vol. 6, no. 6, pp. 2736-2745, Nov. 2015.
- [57] S. Mishra, D. Ramasubramanian and P. C. Sekhar, "A seamless control methodology for a grid connected and isolated PV-diesel microgrid," *IEEE Trans. Power Syst.*, vol. 28, no. 4, pp. 4393-4404, Nov. 2013.
- [58] F. Tang, J. M. Guerrero, J. C. Vasquez, D. Wu and L. X. Meng, "Distributed active synchronization strategy for microgrid seamless reconnection to the grid under unbalance and harmonic distortion," *IEEE Trans. Smart Grid.*, vol. 6, no. 6, pp. 2757-2769, Nov. 2015.
- [59] J. Wang, N. C. P. Chang, X. W. Feng and A. Monti, "Design of a generalized control algorithm for parallel inverters for smooth microgrid transition operation," *IEEE Trans. Ind. Electron.*, vol. 62, no. 8, pp. 4900-4914, Aug. 2015.
- [60] S. M. Ashabani and Y. A. R. I. Mohamed, "A flexible control strategy for grid-connected and islanded microgrids with enhanced stability using nonlinear microgrid stabilizer," *IEEE Trans. Smart Grid.*, vol. 6, no. 6, pp. 1291-1301, Sep. 2012.
- [61] J. A. P. Lopes, C. L. Moreira and A. G. Madureira, "Defining control strategies for microgrids islanded operation," *IEEE Trans. Power Syst.*, vol. 21, no. 2, pp. 916-924, May. 2006.
- [62] F. Katiraei, M. R. Iravani, and P. W. Lehn, "Micro-grid autonomous operation during and subsequent to islanding process," *IEEE Trans. Power Del.*, vol. 20, no. 1, pp. 248-257, Jan. 2005.
- [63] M. Hamzeh, H. Mokhtari and H. Karimi, "A decentralized self-adjusting control strategy for reactive power management in an islanded multi-bus mv microgrid," *Can. J. Elect. Comput. Eng.*, Vol. 36, No. 1, Winter 2013.
- [64] Y. X. Zhu, F. Zhuo, and H. T. Shi, "Accurate power sharing strategy for complex microgrid based on droop control method," in *proc. IEEE ECCE Asia Downunder (ECCE Asia)*, 2013, pp. 344-350.
- [65] D. Wu, F. Tang, J. M. Guerrero, J. C. Vasquez, G. L. Chen, and L. B. Sun, "Autonomous active and reactive power distribution strategy in islanded microgrids," in *proc. IEEE 29th Applied Power Electronics Conference and Exposition Annu. Conf. (APEC)*, 2014, pp. 2126-2131.
- [66] M. Falahi, K. B. Purry and M. Ehsani, "Dynamic reactive power control of islanded microgrids," *IEEE Trans. Power Electron.*, vol. 28, no. 4, pp. 3649-3657, Nov. 2013.
- [67] Y. Wang, Z. Chen, X. F. Wang, Y. J. Tian, Y. D. Tan. C. Yang, "An estimator-based distributed voltage-predictive control strategy for AC islanded microgrids," *IEEE Trans. Power Electron.*, vol. 30, no. 7, pp. 3934-3951, July. 2015.
- [68] Q. W. Liu, Y. Tao, X. H. Liu, Y. Deng, and X. N. He, "Voltage unbalance and harmonics compensation for islanded microgrid inverters," *IET Power Electron.*, vol. 7, no. 5, pp. 1055-1063 2014.
- [69] J. C. Vasquez, J. M. Guerrero, M. Savaghebi, J. E. Garcia and R. Teodorescu, "Modeling, analysis, and design of stationary-reference-frame droop-controlled parallel three-phase voltage source inverters," *IEEE Trans. Ind. Electron.*, vol. 60, no. 4, pp. 1271-1280, Apr. 2013.
- [70] M. Savaghebi, A. Jalilian, J. C. Vasquez and J. M. Guerrero, "Autonomous voltage unbalance compensation in an islanded droop-controlled microgrid," *IEEE Trans. Ind. Electron.*, vol. 60, no. 4, pp. 1390-1402, Apr. 2013.
- [71] H. Jinwei, L. Yun Wei and F. Blaabjerg, "An accurate autonomous islanding microgrid reactive power, imbalance power and harmonic power sharing scheme," in *IEEE Energy Conversion Congress and Exposition (ECCE)*, 2013, pp. 1337-1343.
- [72] J. Schiffer, T. Seel, J. Raisch and T. Sezi, "Voltage stability and reactive power sharing in inverter-based microgrids with consensus-based distributed voltage control," *IEEE Trans. Control Syst. Technol.*, vol. 24, no. 1, pp. 96-109, Jan. 2016.
- [73] J. W. S. Porco, Q. Shafiee, F. Dorfler, J. C. Vasquez, J. M. Guerrero and F. Bullo, "Secondary frequency and voltage control of islanded microgrids via distributed averaging," *IEEE Trans. Ind. Electron.*, vol. 62, no. 11, pp. 7025-7038, Nov. 2015.
- [74] A. Milczarek, M. Malinowski and J. M. Guerrero, "Reactive power management in islanded microgrid-proportional power sharing in hierarchical droop control," *IEEE Trans. Smart Grid.*, vol. 6, no. 4, pp. 1631-1638, Jul. 2015.
- [75] V. Kekatos, G. Wang, A. J. Conejo and G. B. Giannakis, "Stochastic reactive power management in microgrids with renewables," *IEEE Trans. Power Syst.*, vol. 30, no. 6, pp. 3386-3395, Nov. 2015.
- [76] Q. Li, F. X. Chen, M. Chen, J. M. Guerrero and D. Abbott, "Agent-based decentralized control method for islanded microgrids," *IEEE Trans. Smart Grid.*, vol. PP, no. 99, pp. 1-13, 2015.
- [77] S. C. Liu, X. Y. Wang, and P. X. P. Liu, "impact of communication delays on secondary frequency control in an islanded microgrid," *IEEE Trans. Ind. Electron.*, vol. 62, no. 4, pp. 2021-2031, Apr. 2015.
- [78] C. Ahumada, R. Cardenas, D. Saez and J. M. Guerrero, "Secondary control strategies for frequency restoration in islanded microgrids with consideration of communication delays," *IEEE Trans. Smart Grid.*, vol. PP, no. 99, pp. 1-12, 2015.
- [79] V. Nasirian, Q. Shafiee, J. M. Guerrero, F. L. Lewis and A. Davoudi, "Droop-free distributed control for AC microgrids," *IEEE Trans. Power Electron.*, vol. 31, no. 2, pp. 1600-1617, Feb. 2016.
- [80] J. M. Guerrero, L. J. Hang, and J. Uceda, "Control of distributed uninterruptible power supply systems," *IEEE Trans. Ind. Electron.*, vol. 55, no. 8, pp. 2845-2859, Aug. 2008.
- [81] P. T. Cheng, C. A. Chen, T. L. Lee, and S. Y. Kuo, "A cooperative imbalance compensation method for distributed-generation interface converters," *IEEE Trans. Ind. Appl.*, vol. 45, no. 2, pp. 805-815, Mar/Apr. 2009.
- [82] J. M. Guerrero, J. Matas, L. G. D. Vicuna, M. Castilla and J. Miret, "Decentralized control for parallel operation of distributed generation inverters using resistive output impedance," *IEEE Trans. Ind. Electron.*, vol. 54, no. 2, pp. 994-1004, Apr. 2007.
- [83] G. Y. Juan, W. W. Yang, G. X. Qiang and G. H. Rong, "An improved droop controller for grid-connected voltage source inverter in microgrid," in *proc. IEEE 2nd International Power Electronics for Distributed Generation Systems Symposium (PEDG)*, 2010, pp. 823-828.
- [84] J. Kim, J. M. Guerrero, P. Rodriguez, R. Teodorescu and K. Nam, "Mode adaptive droop control with virtual output impedances for an inverter-based flexible ac microgrid," *IEEE Trans. Ind. Electron.*, vol. 26, no. 3, pp. 689-701, Mar. 2011.
- [85] M. Hassanzahraee and A. Bakhshai, "Transient droop control strategy for parallel operation of voltage source converters in an islanded mode microgrid," in *proc. IEEE 33rd International Telecommunications Energy Conf. (INTELEC)*, 2011, pp. 1-9.
- [86] A. Tuladhar, H. Jin, T. Unger and K. Mauch, "Control of parallel inverters in distributed AC power systems with consideration of line impedance effect," *IEEE Trans. Ind. Applicat.*, vol. 36, no. 1, pp. 131-138, Jan/Feb 2000.
- [87] J. Kennedy and R. Eberhart, "Particle swarm optimization," in *Proc. IEEE Int. Conf. Neural Netw.*, 1995, vol. 4, pp. 1942-1948.
- [88] F. Blaabjerg, R. Teodorescu, M. Liserre, and A. V. Timbus, "Overview of control and grid synchronization for distributed power generation systems," *IEEE Trans. Ind. Electron.*, vol. 53, no. 5, pp. 1398-1409, Oct. 2006.
- [89] J. J. Justo, F. Mwasilu, and J. Lee, "AC microgrids versus DC microgrids with distributed energy resources: A review," *Renew. Sustain. Energy Rev.*, vol. 24, pp. 387-405, Aug. 2013.

- [90] M. A. Eltawil and Z. Zhao, "Grid-connected photovoltaic power systems: Technical and potential problems—A review," *Renew. Sustain. Energy Rev.*, vol. 14, no. 1, pp. 112–129, Jan. 2010.
- [91] X. Yu, A. M. Khambadkone, and H. Wang, "Control of parallel connected power converters for low-voltage microgrid—Part I: A hybrid control architecture," *IEEE Trans. Power Electron.*, vol. 25, no. 12, pp. 2962–2970, Dec. 2010.
- [92] C. K. Sao and P. W. Lehn, "Control and power management of converter fed microgrids," *IEEE Trans. Power Syst.*, vol. 23, no. 3, pp. 1088–1098, Aug. 2008.
- [93] A. Tuladhar, H. Jin, and T. Unger, "Parallel operation of single phase inverter modules with no control interconnections," in *Proc. 12th Annu. IEEE Appl. Power Electron. Expo.*, Atlanta, GA, USA, 1997, pp. 94–100.
- [94] J. C. Vasquez, J. M. Guerrero, and A. Luna, "Adaptive droop control applied to voltage-source inverters operating in grid-connected and islanded modes," *IEEE Trans. Ind. Electron.*, vol. 56, no. 10, pp. 4088–4096, Oct. 2009.
- [95] J. M. Guerrero, J. Matas, V. L. De, M. Castilla, and J. Miret, "Wireless control strategy for parallel operation of distributed-generation inverters," *IEEE Trans. Ind. Electron.*, vol. 53, no. 5, pp. 1461–1470, Oct. 2006.
- [96] J. M. Guerrero, J. C. Vasquez, J. Matas, M. Castilla, and V. L. De, "Control strategy for flexible microgrid based on parallel line-interactive UPS systems," *IEEE Trans. Ind. Electron.*, vol. 56, no. 3, pp. 726–736, Mar. 2009.
- [97] J. Chen, L. Wang, L. J. Diao, H. Q. Du and Z. G. Liu, "Distributed auxiliary inverter of urban rail train—load sharing control strategy under complicated operation condition," *IEEE Trans. Power Electron.*, vol. 31, no. 3, pp. 2518–2529, Mar. 2016.
- [98] Q. Shafiee, J. M. Guerrero, and J. Vasquez, "Distributed secondary control for islanded microgrids—A novel approach," *IEEE Trans. Power Electron.*, vol. 29, no. 2, pp. 1018–1031, Feb. 2014.
- [99] H. Liang, B. J. Choi, and W. Zhuang, "Stability enhancement of decentralized inverter control through wireless communications in microgrids," *IEEE Trans. Smart Grid.*, vol. 4, no. 1, pp. 321–331, Mar. 2013.
- [100] Q. C. Zhong, "Robust droop controller for accurate proportional load sharing among inverters operated in parallel," *IEEE Trans. Ind. Electron.*, vol. 60, no. 4, pp. 1281–1290, Apr. 2013.
- [101] I. U. Nutkani, P. C. Loh, P. Wang, and F. Blaabjerg, "Autonomous droop scheme with reduced generation cost," *IEEE Trans. Ind. Electron.*, vol. 61, no. 12, pp. 6803–6811, Dec. 2014.
- [102] I. U. Nutkani, P. C. Loh, and F. Blaabjerg, "Droop scheme with consideration of operating costs," *IEEE Trans. Power Electron.*, vol. 29, no. 3, pp. 1047–1052, Mar. 2014.
- [103] I. U. Nutkani, P. C. Loh, W. Peng, and F. Blaabjerg, "Cost-prioritized droop schemes for autonomous AC microgrids," *IEEE Trans. Power Electron.*, vol. 30, no. 2, pp. 1109–1119, Feb. 2015.
- [104] Y. Q. Jia, L. D. K. Liu, and J. Liu, "A novel seamless transfer method for a microgrid based on droop characteristic adjustment," in *proc. 7th International Power Electronics and Motion Control Conference (IPEMC)*, 2012, pp. 362–367.
- [105] O. Palizban, and K. kaohaniemi, "Hierarchical control structure in microgrids with distributed generation: island and grid-connected mode," *Renew. Sustain. Energy Rev.*, vol. 44, pp. 797–813, Apr. 2015.
- [106] W. F. D. Souza, M. A. S. Mendes and L. A. C. Lopes, "Power sharing control strategies for a three-phase microgrid in different operating condition with droop control and damping factor investigation," *IET Renew. Power Gener.*, vol. 9, no. 7, pp. 831–839, 2015.
- [107] M. A. Mahmud, M. J. Hossain, H. R. Pota and A. M. T. Oo, "robust nonlinear distributed controller design for active and reactive power sharing in islanded microgrids," *IEEE Trans. Energy Convers.*, vol. 29, no. 4, pp. 893–903, Dec. 2014.
- [108] Y. X. Zhu, F. Zhuo, F. Wang, B. Q. Liu, R. F. Gou and Y. J. Zhao, "A virtual impedance optimization method for reactive power sharing in networked microgrid," *IEEE Trans. Power Electron.*, vol. 31, no. 4, pp. 2890–2904, Apr. 2016.
- [109] H. G. Zhang, S. Kim, Q. Y. Sun and J. G. Zhou, "Distributed adaptive virtual impedance control for accurate reactive power sharing based on consensus control in microgrids," *IEEE Trans. Smart Grid.*, vol. PP, no. 99, 2016.
- [110] T. C. Green and M. Prodanovic, "Control of inverter-based micro-grids," *Electr. Power Syst. Res.*, vol. 77, no. 9, pp. 1204–1213, Jul. 2007.
- [111] F. Katiraei, R. Iravani, N. Hatzigiargyriou, and A. Dimeas, "Microgrids management," *IEEE Power Energy Mag.*, vol. 6, no. 3, pp. 54–65, May/Jun. 2008.
- [112] J. Rocabert, A. Luna, F. Blaabjerg, and P. Rodriguez, "Control of power converters in AC microgrids," *IEEE Trans. Power Electron.*, vol. 27, no. 11, pp. 4734–4749, Nov. 2012.
- [113] L. Y. Lu, and C. C. Chu, "Autonomous power management and load sharing in isolated micro-grids by consensus-based droop control of power converters," in *proc. 1st International Future Energy Electronics Conf. (IFEEC)*, 2013, pp. 365–370.
- [114] M. Nelson and P. E. Jordan, "Automatic reconfiguration of a ship's power system using graph theory principles," *IEEE Trans. Ind. Applicat.*, vol. 51, no. 3, pp. 2651–2656, May/Jun. 2015.
- [115] W. Ni, I. B. Collings, X. Wang, M. X. Tao, and M. Abolhasan, "Graph theory and its applications to future network planning: software-defined online small cell management," *IEEE Trans. Wireless Commun.*, vol. 22, no. 1, pp. 52–60, Feb. 2015.
- [116] C. Zhang, W. X. Li, and K. Wang, "Graph theory-based approach for stability analysis of stochastic coupled systems with levy noise on networks," *IEEE Trans. Neural Netw.*, vol. 26, no. 8, pp. 1698–1709, Aug. 2015.
- [117] D. W. He, D. Shi, and R. Sharma, "Consensus-based distributed cooperative control for microgrid voltage regulation and reactive power sharing," in *proc. IEEE PES Innovative Smart Grid Technologies Conf. Europe (ISGT-Europe)*, 2014, pp. 1–6.
- [118] J. F. Hu, J. G. Zhu, and G. Platt, "A droop control strategy of parallel-inverter-based microgrid," in *proc. International Applied Superconductivity and Electromagnetic Devices Conf. (ASEMD)*, 2011, pp. 188–191.
- [119] G. W. Zhang, Z. H. Jin, N. N. Li, X. Hu, and X. S. Tang, "A novel control strategy for parallel-connected converters in low voltage microgrid," in *proc. IEEE Transportation Electrification Asia-Pacific Conf. and Expo. (ITEC Asia-Pacific)*, 2014, pp. 1–6.
- [120] L. Meng, F. Zhang, Z. K. Li, and J. Fu, "Analyzing the possibility of parallel resonance in enterprise microgrid with frequency scanning method," in *proc. Asia-Pacific Power and Energy Engineering Conf. (APPEEC)*, 2012, pp. 1–4.
- [121] O. d. S. Perez, J. Miret, A. Camacho, P. Marti and R. Guzman, "Power sharing control in islanded microgrid using event driven communication," in *proc. IEEE 39th Industrial Electronics Society Annu. Conf. (IECON)*, 2013, pp. 2151–2156.
- [122] D. I. Vokony and D. A. Dan, "Reactive power- and voltage regulation in smart grid environment," in *proc. IEEE Grenoble PowerTech (POWERTECH)*, 2013, pp. 1–9.
- [123] H. E. Farag, M. M. A. Abdelaziz and E. F. E. Saadany, "Voltage and reactive power impacts on successful operation of islanded microgrids," *IEEE Trans. Power Syst.*, vol. 28, no. 2, pp. 1716–1727, May. 2013.
- [124] J. Choi, "Iterative methods for physical-layer multicast beamforming," *IEEE Trans. Wireless Commun.*, vol. 14, no. 9, pp. 5185–5196, Sep. 2015.
- [125] Z. Z. Miao, and P. Kosmas, "Microwave breast imaging based on an optimized two-step iterative shrinkage/thresholding method," in *9th Antennas and Propagation European Conf. (EuCAP)*, 2015, pp. 1–4.
- [126] X. J. Bo, W. H. Qiang, and G. S. Feng, "A novel service recovery method based upon bellman dynamic programming," in *proc. International Computer and Information Application Conf. (ICCIA)*, 2010, pp. 110–115.
- [127] Y. Wang and Q. Y. Jiang, "Reactive power optimization of distribution network based on primal-dual interior point method and simplified branch and bound method," in *proc. IEEE PES T and D Conf. and Exposition*, 2014, pp. 1–4.
- [128] K. Iwasawa, "Detecting method of parallelism from nested loops with loop carried data dependences," in *proc. 5th International Computing in the Global Information Technology Multi-Conf. (ICCGI)*, 2010, pp. 287–292.
- [129] P. Arato and G. Suba, "A data flow graph generation method starting from C description by handling loop nest hierarchy," in *proc. IEEE 9th International Applied Computational Intelligence and Informatics Symposium (SACI)*, 2014, pp. 269–274.
- [130] N. R. Jennings and S. Bussmann, "Agent-based control systems: why are they suited to engineering complex systems?" *IEEE control systems magazine*, vol. 23, no. 3, pp. 61–73, Jun. 2003.
- [131] Y. M. Shao, Y. Wu, and Y. T. Chen, "Design and research of multi-agent control system for central cooling system," in *proc. IEEE 3rd International Cloud Computing and Intelligence Systems Conf. (CCIS)*, 2014, pp. 218–221.
- [132] A. K. Pandey and R. Pandey, "Role of multi agent system methodology in system design," in *proc. 2nd International Computing for Sustainable Global Development Conf. (INDIACom)*, 2015, pp. 438–441.
- [133] C. M. Colson and M. H. Nehrir, "Algorithms for distributed decision-making for multi-agent microgrid power management," in *proc. IEEE Power and Energy Society General Meet.*, 2011 pp. 1–8.
- [134] L. Z. Liu, L. Qian, and H. T. Song, "Intelligent group decision support system for cooperative works based on multi-agent system," in *proc. 10th International Computer Supported Cooperative Work in Design Conf. (CSCWD)*, 2006, pp. 1–5.
- [135] K. Wilkosz, "Utilization of multi-agent system for power system topology verification," in *proc. 15th International Electric Power Engineering Scientific Conf. (EPE)*, 2014, pp. 3–6.
- [136] J. W. He, and Y. W. Li, "An accurate reactive power sharing control strategy for DG units in a microgrid," in *proc. IEEE 8th International Power Electronics and ECCE Asia Conf. (ICPE and ECCE)*, 2011, pp. 551–556.
- [137] A. Haddadi, A. Shojaei and B. Boulet, "Enabling high droop gain for improvement of reactive power sharing accuracy in an electronically-interfaced autonomous microgrid," in *proc. IEEE Energy Conversion Congress and Exposition (ECCE)*, 2011, pp. 673–679.

- [138] W. S. Deng, and C. H. Deng, "Study on dynamic reactive compensation capacity of a microgrid with high permeability photovoltaic power," in *proc. International Electrical and Control Engineering Conf. (ICECE)*, 2011, pp. 5015-5018.
- [139] T. L. Vandoom, B. Renders, B. Meersman, L. Degroote and L. Vandeveld, "Reactive power sharing in an islanded microgrid," in *proc. 45th International Universities Power Engineering Conf. (UPEC)*, 2010, pp. 1-6.
- [140] J. W. He, Y. W. Li, J. M. Guerrero, J. C. Vasquez and F. Blaabjerg, "An islanding microgrid reactive power sharing scheme enhanced by programmed virtual impedances," in *proc. IEEE 3rd International Power Electronics for Distributed Generation Systems Symposium (PEDG)*, 2012, pp. 229-235.
- [141] A. Micallef, M. Apap, C. Spiteri-Staines and J. M. Guerrero, "Secondary control for reactive power sharing in droop-controlled islanded microgrids," in *IEEE International Symposium on Industrial Electronics (ISIE)*, 2012, pp. 1627-1633.
- [142] A. Bidram, A. Davoudi and F. L. Lewis, "Two-layer distributed cooperative control of multi-inverter microgrids," in *proc. IEEE 29th Applied Power Electronics Conference and Exposition Annu. Conf. (APEC)*, 2014, pp. 2364-2371.
- [143] J. W. He, Y. W. Li, and F. Blaabjerg, "An enhanced islanding microgrid reactive power, imbalance power, and harmonic power sharing scheme," *IEEE Trans. Power Electron.*, vol. 30, no. 6, pp. 3389-3401, Jun. 2015.
- [144] A. Micallef, M. Apap, C. S. Staines, J. M. Guerrero and J. C. Vasquez, "Reactive power sharing and voltage harmonic distortion compensation of droop controlled single phase islanded microgrids," *IEEE Trans. Smart Grid.*, vol. 5, no. 3, pp. 1149-1158, May. 2014.
- [145] M. Yazdani and A. Mehrizi-Sani, "Washout filter-based power sharing," *IEEE Trans. Smart Grid.*, vol. PP, no. 99, pp. 1-2, 2015.
- [146] J. Wang, P. Shi, H. Gao and J. Wang, "Gain-scheduled stabilization of linear parameter-varying systems with time-varying input delay," *IET Control Theory Appl.*, Vol. 1, No. 5, pp. 1276-1285, Sep. 2007.
- [147] Y. Y. Yin, P. Shi and F. Liu, "Gain-scheduled robust fault detection on time-delay stochastic nonlinear systems," *IEEE Trans. Ind. Electron.*, vol. 56, no. 10, pp. 4908-4916, Oct. 2011.
- [148] H. T. Pham and J. T. Lim, "Gain scheduling for non-linear time-delay systems using approximated model," *IET Control Theory Appl.*, Vol. 6, no. 1, pp. 157-164, 2012.
- [149] Y. Liang and H. J. Marquez, "Robust gain scheduling synchronization method for quadratic chaotic systems with channel time delay," *IEEE Trans. Circuits Syst.*, vol. 56, no. 6, pp. 604-615, Mar. 2009.
- [150] P. Shi, R. N. Yang, M. Basin and H. R. Karimi, "Predictive control of networked systems with communication delays," in *proc. IEEE International Intelligent Control Symposium (ISIC)*, 2012, pp. 1166-1171.
- [151] T. Y. Zhang, and G. P. Liu, "Limit-bandwidth networked predictive control of systems with communication delay and data loss in the feedback channel," in *11th Intelligent Control and Automation World Congress (WCICA)*, 2014, pp. 3925-3930.
- [152] S. V. Ghoshkhanehe and A. Alfi, "Model predictive control of transparent bilateral teleoperation systems under uncertain communication time-delay," in *proc. 9th Asian Control Conf. (ASCC)*, 2013, pp. 1-6.
- [153] L. J. Gang, Z. Hong, H. W. Shan, and L. X. Qing, "Distributed secondary control for reactive power sharing of inverter-based DGs in microgrids," in *proc. 34th Chinese Control Conf. (CCC)*, 2015, pp. 8990-8995.
- [154] H. Behjati, A. Davoudi and F. Lewis, "Modular DC-DC converters on graphs: cooperative control," *IEEE Trans. Power Electron.*, vol. 29, no. 12, pp. 6725-6741, Dec. 2014.
- [155] L. Z. Feng, and Q. Z. Yuan, "Coordination control based on multi-agent for DC micro-grid," in *proc. 27th Chinese Control and Decision Conf. (CCDC)*, 2015, pp. 4803-4806.
- [156] F. G. Torres, C. Bordons and S. Vazquez, "Voltage predictive control for microgrids in islanded mode based on fourier transform," in *proc. IEEE International Industrial Technology Conf. (ICIT)*, 2015, pp. 2358-2363.
- [157] P. S. Shete, N. S. Maurya, R. M. Moharil and A. A. Dutta, "Analysis of micro-grid under different loading conditions," in *proc. International Industrial Instrumentation and Control Conf. (IIC)*, 2015, pp. 1120-1124.
- [158] R. R. D. Lima, F. C. Melo, L. S. Garcia, L. C. Freitas, E. A. A. Coelho, V. J. Farias, and L. C. G. Freitas, "Design and modeling of a transformerless hybrid inverter system using a fuel cell as energy storage element for microgrids with sensitive loads," in *proc. 6th IEEE International Power Electronics for Distributed Generation Systems Symposium (PEDG)*, 2015, pp. 1-8.
- [159] M. Farhadi and O. A. Mohammed, "Hybrid DC power system for pulse load application: design, modeling and operation," in *proc. IEEE 7th Green Technologies Annu. Conf. (GreenTech)*, 2015, pp. 152-157.
- [160] A. Banerji, S. K. Biswas and B. Singh, "Enhancing quality of power to sensitive loads with microgrid," *IEEE Trans. Industry Applications.*, vol. PP, no. 99, pp. 1-1, 2015.
- [161] A. G. Tsikalakis and N. D. Hatziargyriou, "Centralized control for optimizing microgrids operation," *IEEE Trans. Energy Convers.*, vol. 23, no. 1, pp. 241-248, Mar. 2008.
- [162] Z. Q. Yao, L. S. Rong, Z. Ying, C. X. Ting, and Z. L. Wei, "Economic dispatch of distribution network with multi-microgrid," in *proc. 34th Chinese Control Conference (CCC)*, 2015, pp. 9060-9065.
- [163] S. Mukherjee, R. Chakraborty and S. K. Goswami, "Economic generation scheduling in microgrid with pumped-hydro unit using particle swarm optimization," in *proc. IEEE International Electrical, Computer and Communication Technologies Conf. (ICECCT)*, 2015, pp. 1-5.
- [164] A. Bracale, P. Caramia and F. Mottola, "A cost minimization strategy for the control of hybrid AC-DC microgrids in industrial systems," in *proc. International Clean Electrical Power Conf. (ICCEP)*, 2015, pp. 40-47.
- [165] F. Z. Liu, H. J. Gao, J. B. Qiu, S. Yin, J. L. Fan, and T. Y. Chai, "Networked multirate output feedback control for setpoints compensation and its application to rougher flotation process," *IEEE Trans. Ind. Electron.*, vol. 61, no. 1, pp. 460-468, Jan. 2014.
- [166] S. K. Mazumder, M. Tahir and K. Acharya, "Master-slave current-sharing control of a parallel DC-DC converter system over an RF communication interface," *IEEE Trans. Ind. Electron.*, vol. 55, no. 1, pp. 59-66, Jan. 2008.
- [167] H. B. Li, Z. Q. Sun, M.Y. Chow, and F. C. Sun, "Gain-scheduling-based state feedback integral control for networked control systems," *IEEE Trans. Ind. Electron.*, vol. 58, no. 6, pp. 2465-2472, Jun. 2011.
- [168] Y. Shi, J. Huang, and B. Yu, "Robust tracking control of networked control systems: application to a networked DC motor," *IEEE Trans. Ind. Electron.*, vol. 60, no. 12, pp. 5864-5874, Dec. 2013.
- [169] Y. Chompoobutgool and L. Vanfretti, "Analysis of time delay effects for wide-area damping control design using dominant path signals," in *proc. IEEE PES General Meet.* 2014, pp. 1-5.

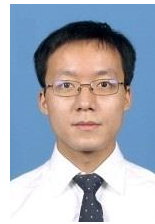

Yang Han (S'08-M'10) received the B.S. degree in Electrical Engineering from University of Electronic Science and Technology of China (UESTC), Chengdu, China, in 2004, and received the Ph.D. in Electrical Engineering from Shanghai Jiaotong University (SJTU), Shanghai, China, in 2010. He joined the Department of Power Electronics, School of Mechatronics Engineering, University of Electronic Science and Technology of China (UESTC) in 2010, and has been promoted to an Associate Professor since 2013. From March 2014 to March 2015, he was a visiting scholar (guest postdoc) in the area of

renewable energy and microgrids at the Department of Energy Technology, Aalborg University, Aalborg, Denmark. His research interests include AC/DC microgrids, grid-connected converters for renewable energy systems and DGs, phase-locked loop (PLL), power quality, active power filters and static synchronous compensators (STATCOMs).

He has authored more than 20 ISI-indexed journal papers and one book chapter in the area of power electronics, power quality conditioners, and smart grid. He received Best Paper Awards from 2013 Annual Conference of HVDC and Power Electronics Committee of Chinese Society of Electrical Engineers (CSEE) in Chongqing, China, and the 4th International Conference on Power Quality in 2008, in Yangzhou, China. He has six issued and ten pending patents. Currently, he is the supervisor for nine master students, one of which has been nominated as provincial outstanding graduate student. He is an active reviewer for IEEE Transactions on Power Electronics, IEEE Transactions on Smart Grid, IEEE Transactions on Industrial Electronics, IEEE Transactions on Sustainable Energy and IEEE Transactions on Energy Conversion.



Hong Li received the B.S. degree in Electrical Engineering and Automation from University of Electronic Science and Technology of China (UESTC), Chengdu, China, in 2015. He is currently working towards the M.S. degree in Power Electronics and Electric Drives at UESTC, Chengdu, China. His current research interests include the optimization of ac microgrids, power management, hierarchical and cooperative control, and grid-integration of renewable energy resources.



Pan Shen received his B.S. in Electrical Engineering and Automation from Anhui Agricultural University, Hefei, China, in 2013. He is currently working toward the M.S. degree in Power Electronics and Electric Drives at the University of Electronic Science and Technology of China (UESTC), Chengdu, China. His current research interests include ac/dc microgrid, power quality, power converters, power system automation, and active power filters.



Ernane Antônio Alves Coelho received the B.S. degree in electrical engineering from the Federal University of Minas Gerais, Belo Horizonte, Brazil, the M.S. degree from the Federal University of Santa Catarina, Florianopolis, Brazil, and the Ph.D. degree from the Federal University of Minas Gerais in 1987, 1989, and 2000, respectively. In 1989, he joined the Electrical Engineering Faculty at Federal University of Uberlandia, where he is currently a Full Professor. His research interests are Power-factor Correction, PV and Fuel Cell Systems, Microgrid Modelling and Digital Control by microcontrollers and DSP's.



Josep M. Guerrero (S'01-M'04-SM'08-FM'15) received the B.S. degree in telecommunications engineering, the M.S. degree in electronics engineering, and the Ph.D. degree in power electronics from the Technical University of Catalonia, Barcelona, in 1997, 2000 and 2003, respectively. Since 2011, he has been a Full Professor with the Department of Energy Technology, Aalborg University, Denmark, where he is responsible for the Microgrid Research Program. From 2012 he is a guest Professor at the Chinese Academy of Science and the Nanjing University of Aeronautics and Astronautics; from 2014 he is chair Professor in Shandong University; from 2015 he is a distinguished guest Professor in Hunan University; and from 2016 he is a visiting professor fellow at Aston University, UK.

His research interests is oriented to different microgrid aspects, including power electronics, distributed energy-storage systems, hierarchical and cooperative control, energy management systems, smart metering and the internet of things for AC/DC microgrid clusters and islanded minigrids; recently specially focused on maritime microgrids for electrical ships, vessels, ferries and seaports. Prof. Guerrero is an Associate Editor for the IEEE TRANSACTIONS ON POWER ELECTRONICS, the IEEE TRANSACTIONS ON INDUSTRIAL ELECTRONICS, and the IEEE Industrial Electronics Magazine, and an Editor for the IEEE TRANSACTIONS ON SMART GRID and IEEE TRANSACTIONS ON ENERGY CONVERSION. He has been Guest Editor of the IEEE TRANSACTIONS ON POWER ELECTRONICS Special Issues: Power Electronics for Wind Energy Conversion and Power Electronics for Microgrids; the IEEE TRANSACTIONS ON INDUSTRIAL ELECTRONICS Special Sections: Uninterruptible Power Supplies systems, Renewable Energy Systems, Distributed Generation and Microgrids, and Industrial Applications and Implementation Issues of the Kalman Filter; the IEEE TRANSACTIONS ON SMART GRID Special Issues: Smart DC Distribution Systems and Power Quality in Smart Grids; the IEEE TRANSACTIONS ON ENERGY CONVERSION Special Issue on Energy Conversion in Next-generation Electric Ships. He was the chair of the Renewable Energy Systems Technical Committee of the IEEE Industrial Electronics Society. He received the best paper award of the IEEE Transactions on Energy Conversion for the period 2014-2015. In 2014 and 2015 he was awarded by Thomson Reuters as Highly Cited Researcher, and in 2015 he was elevated as IEEE Fellow for his contributions on "distributed power systems and microgrids."